

Joseph Lstiburek, Ph.D., P.Eng, ASHRAE Fellow

# Building Science

Adventures In Building Science

[www.buildingscience.com](http://www.buildingscience.com)

Life is Tough Enough As it Is...

Building Science Corporation

Joseph Lstiburek 2

Life is Tough Enough As it Is...  
It's Harder When You Are Stupid

Building Science Corporation

Joseph Lstiburek 3

Don't Do Stupid Things

Building Science Corporation

Joseph Lstiburek 4

## Environmental Separator

Building Science Corporation

Joseph Lstiburek 5

- Control heat flow
- Control airflow
- Control water vapor flow
- Control rain
- Control ground water
- Control light and solar radiation
- Control noise and vibrations
- Control contaminants, environmental hazards and odors
- Control insects, rodents and vermin
- Control fire
- Provide strength and rigidity
- Be durable
- Be aesthetically pleasing
- Be economical

Building Science Corporation

Joseph Lstiburek 6

Heat Flow Is From Warm To Cold  
Moisture Flow Is From Warm To Cold  
Moisture Flow Is From More To Less  
Air Flow Is From A Higher Pressure to a  
Lower Pressure  
Gravity Acts Down

Building Science Corporation

Joseph Lstiburek 7

Water Control Layer  
Air Control Layer  
Vapor Control Layer  
Thermal Control Layer

Building Science Corporation

Joseph Lstiburek 8

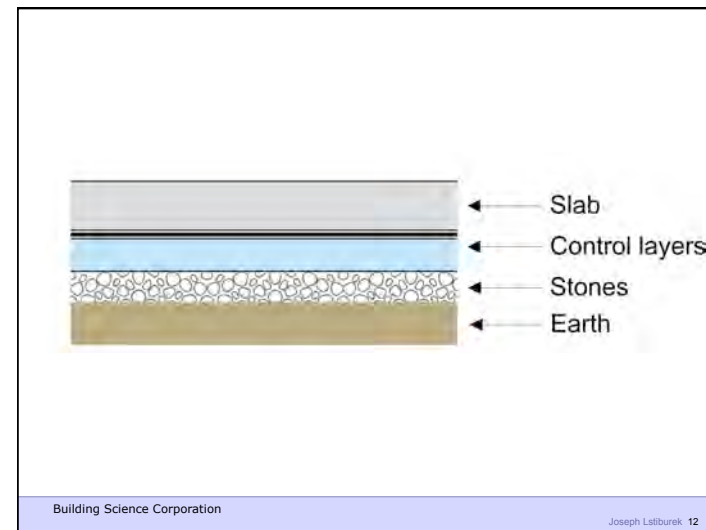
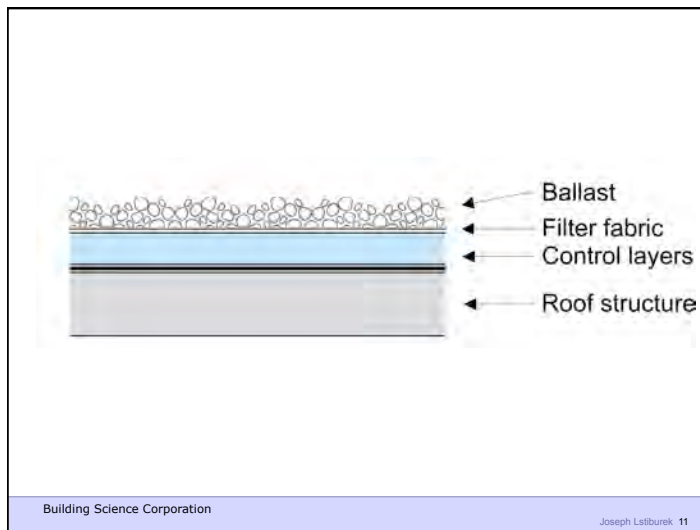
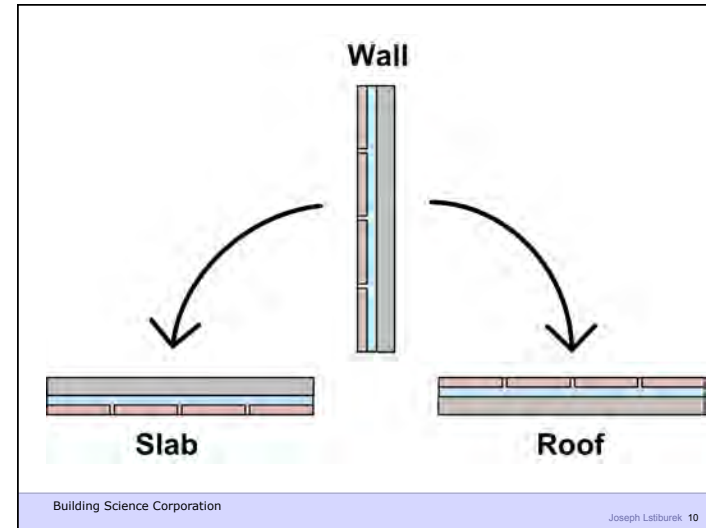
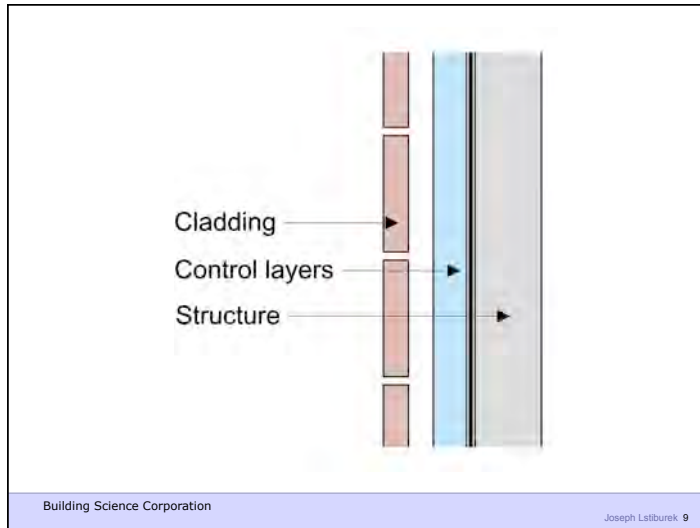

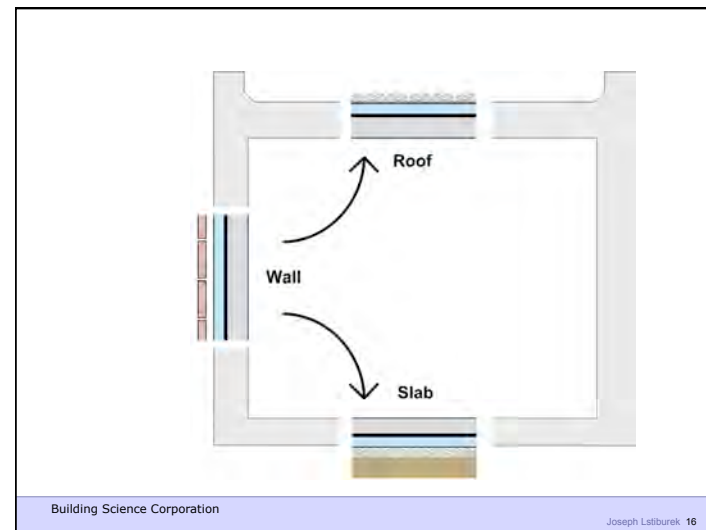
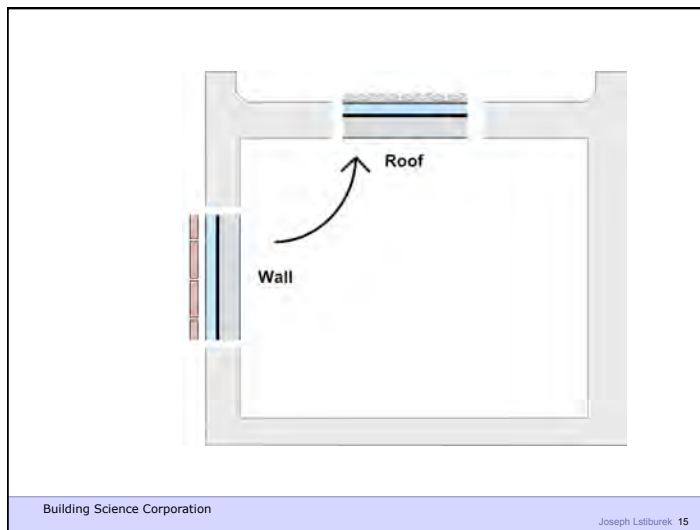
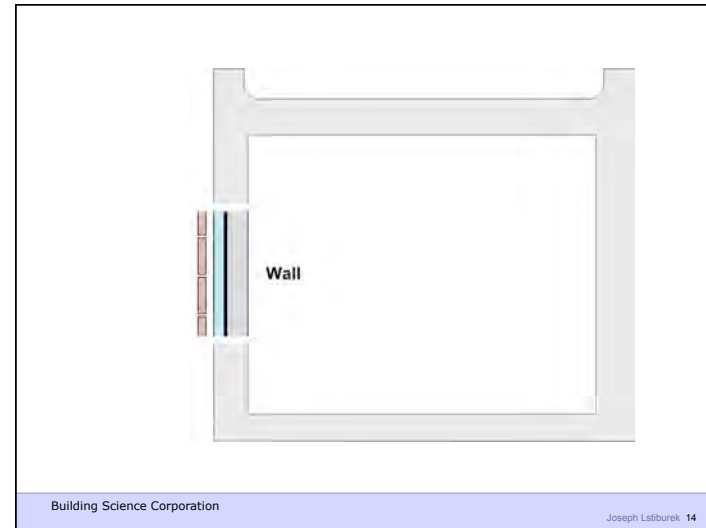
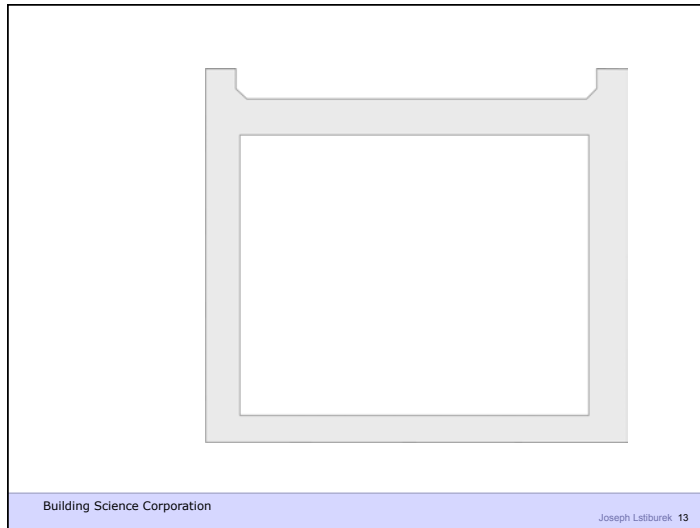

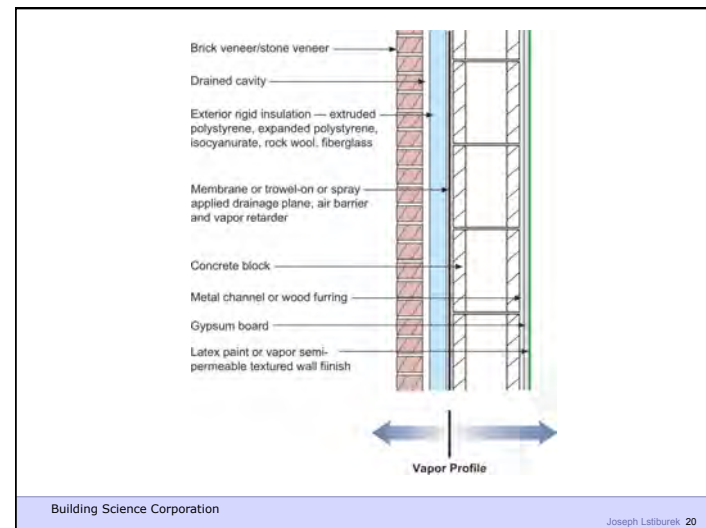
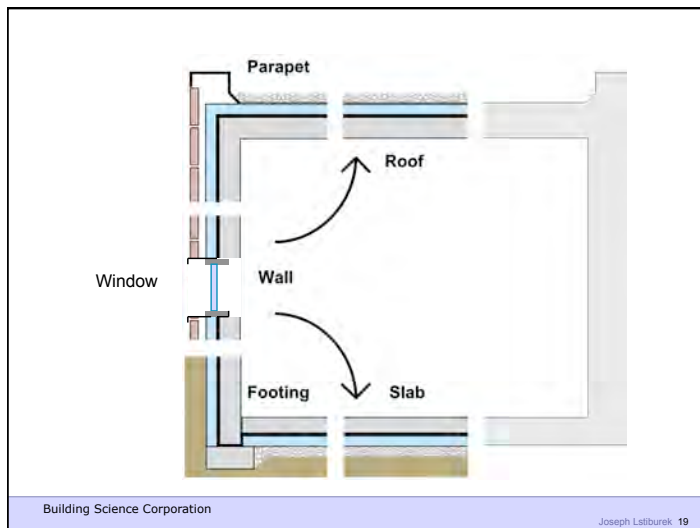
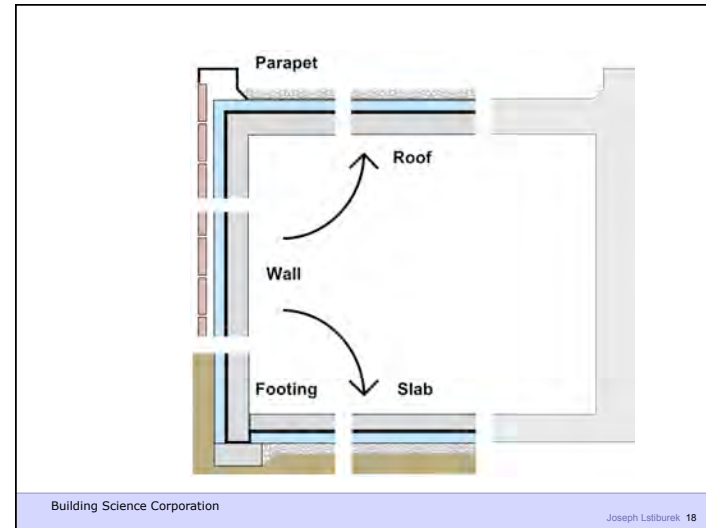
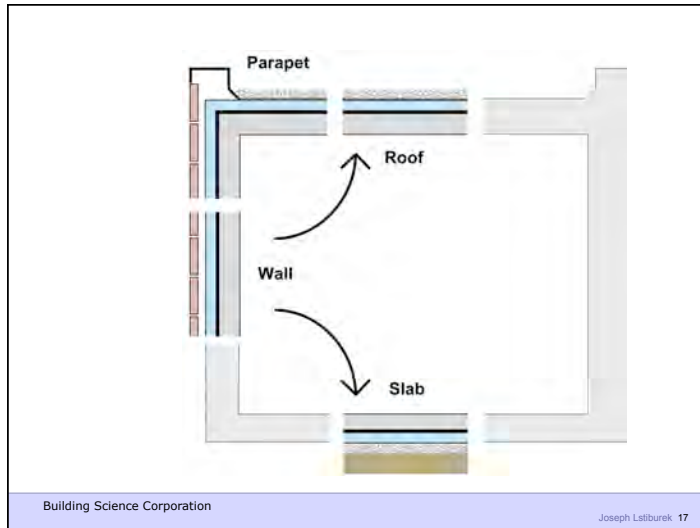

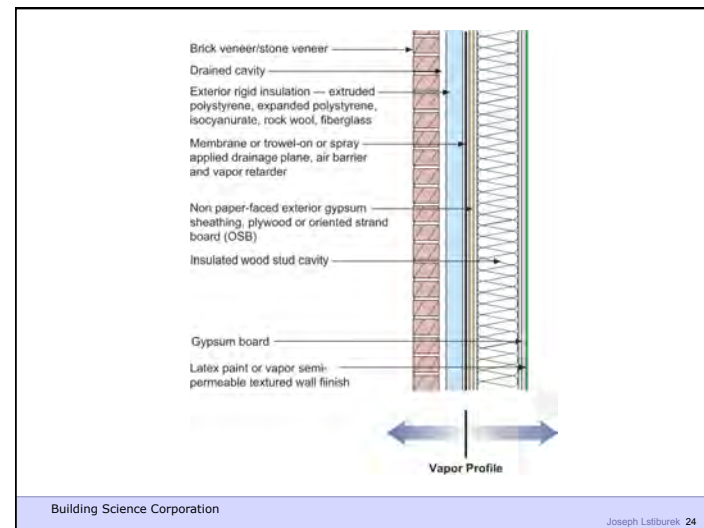
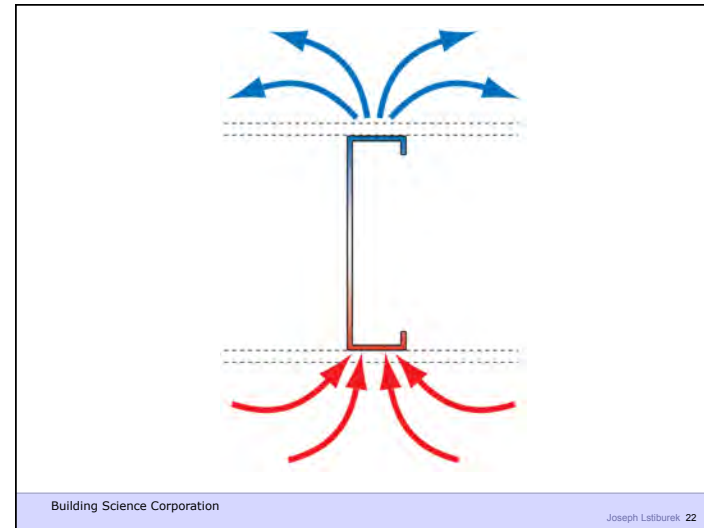
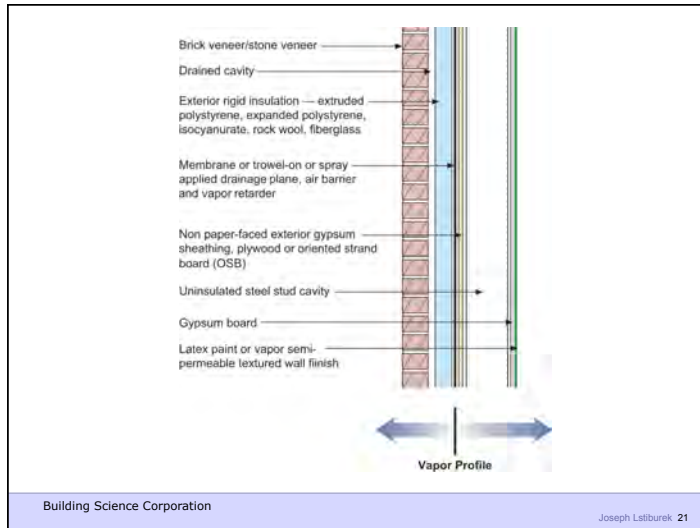

### Commercial Enclosure: Simple Layers



- Structure
- Rain/Air/Vapor
- Insulation
- Finish

Building Science Corporation

Joseph Lstiburek 25

### Enclosure Design: Details

- Details demand the same approach as the enclosure.
- Scaled drawings required at 

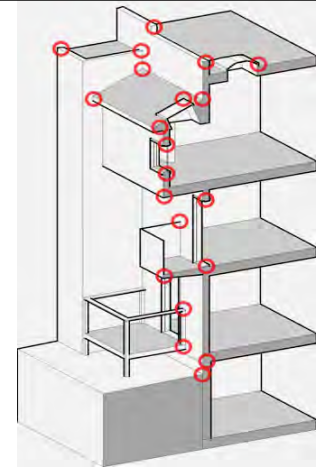

Building Science Corporation

Joseph Lstiburek 26

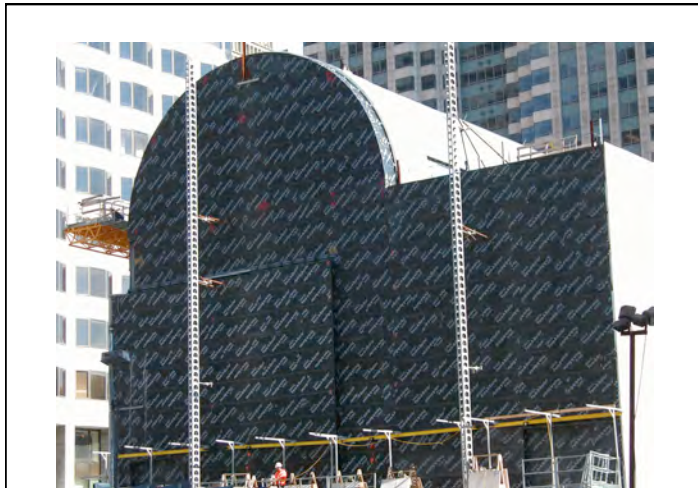

Building Science Corporation

Joseph Lstiburek 27

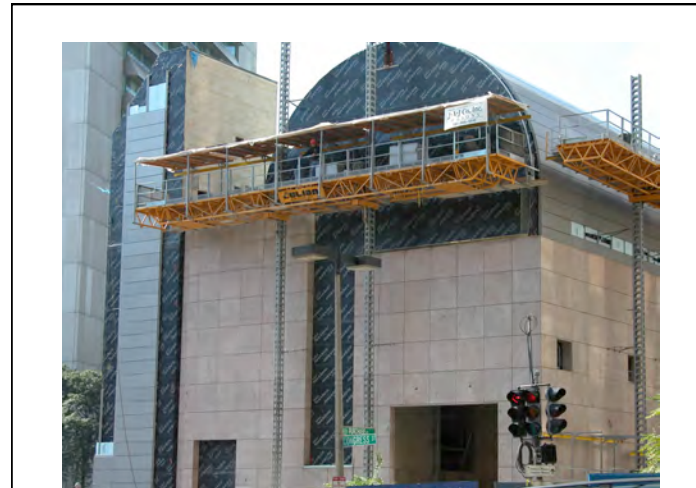

Building Science Corporation

Joseph Lstiburek 28



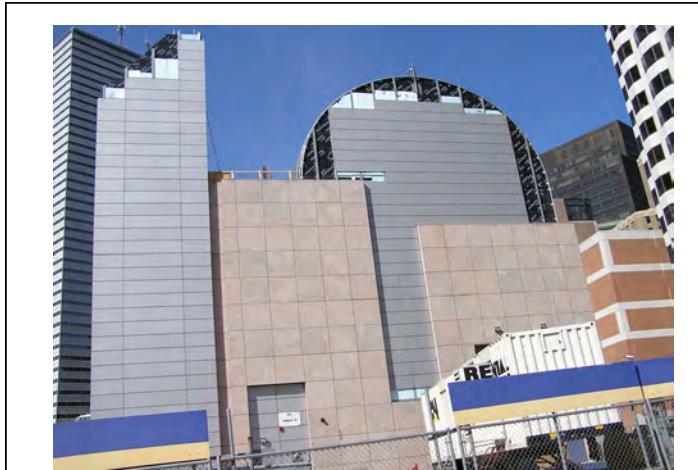

Building Science Corporation

Joseph Lstiburek 29



Building Science Corporation

Joseph Lstiburek 30



Building Science Corporation

Joseph Lstiburek 31

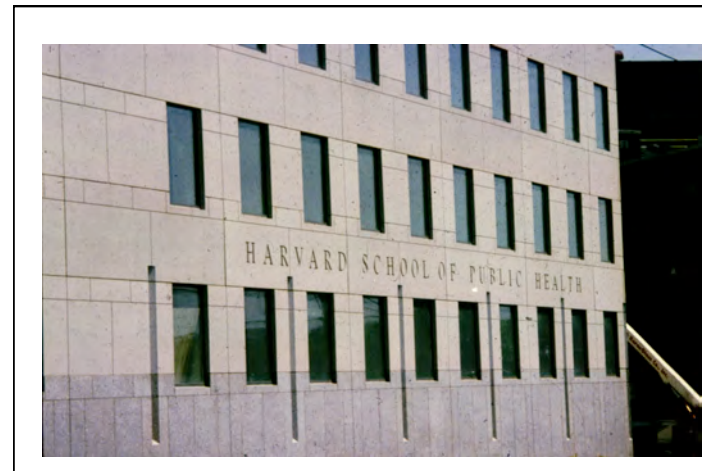

Building Science Corporation

Joseph Lstiburek 32



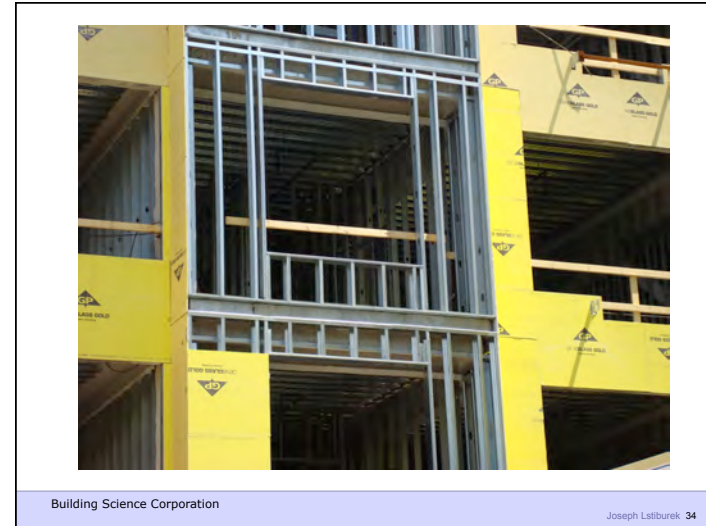

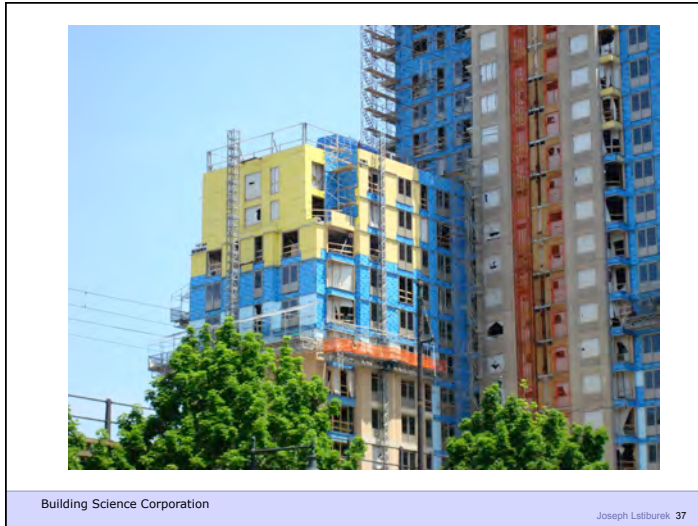

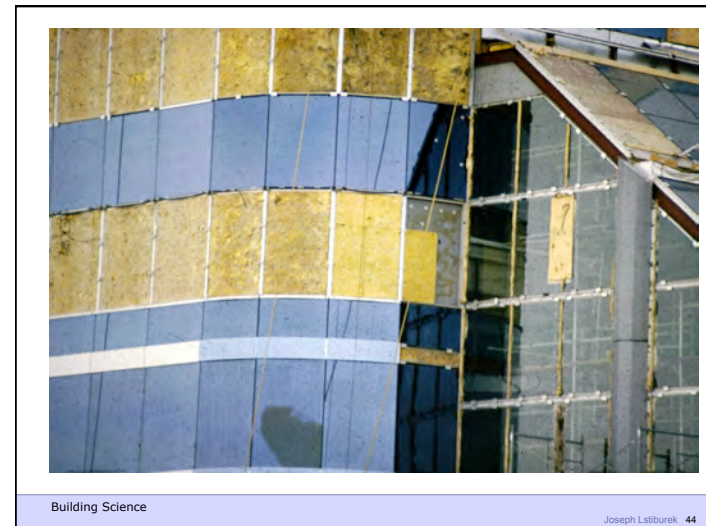
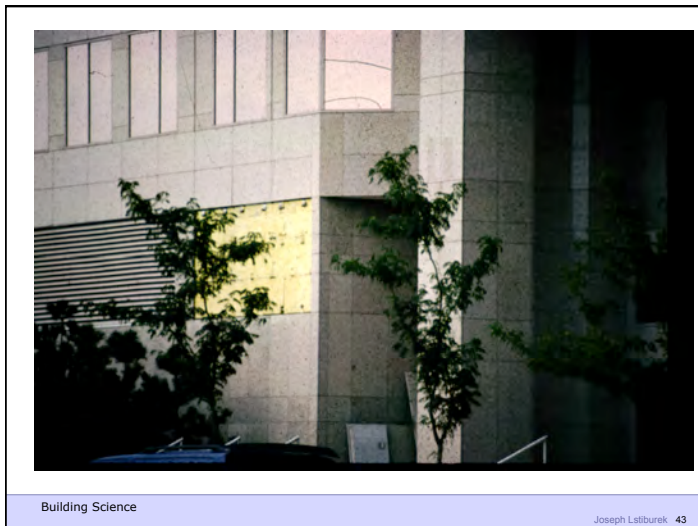
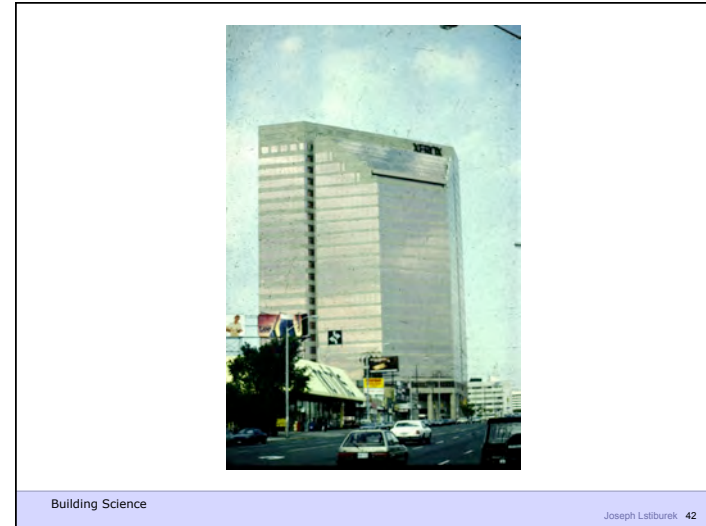
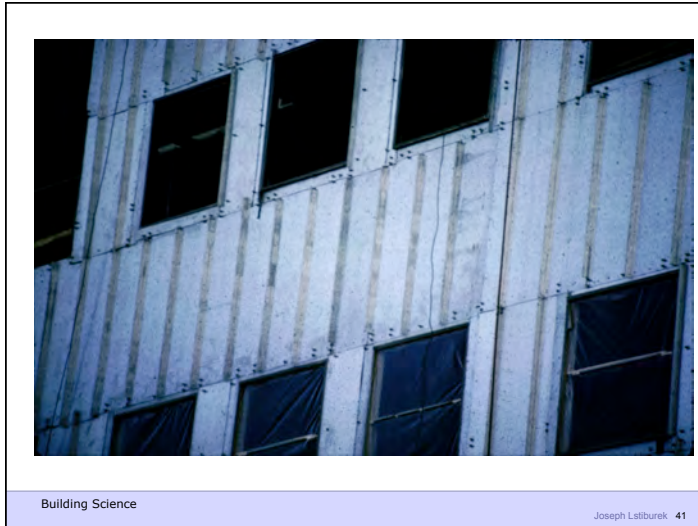





45



46



47

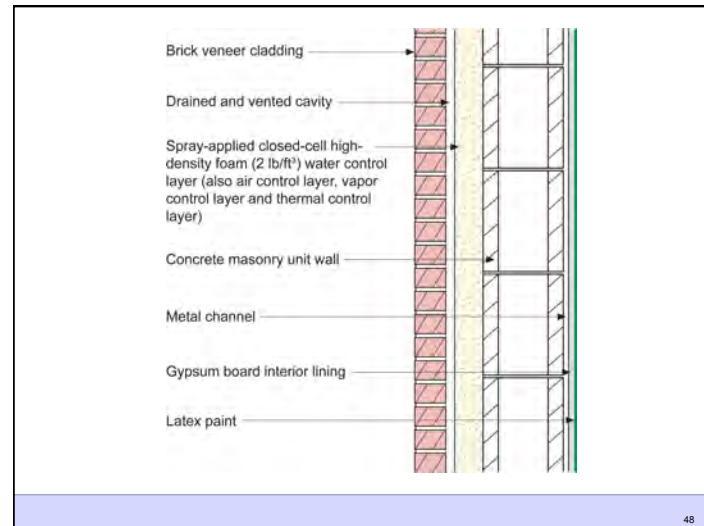

48

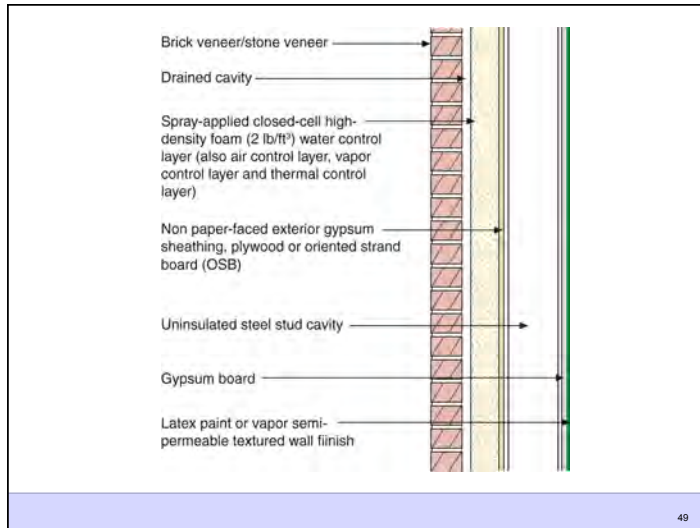

Don't Do Stupid Things

Building Science Corporation

Joseph Lstiburek 50

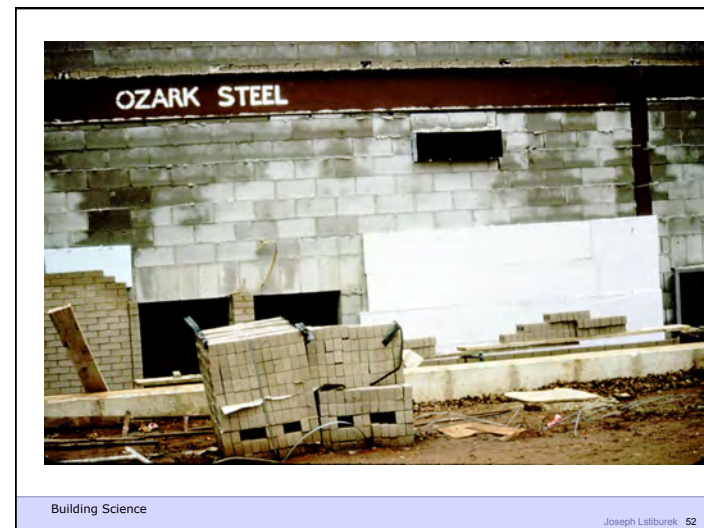

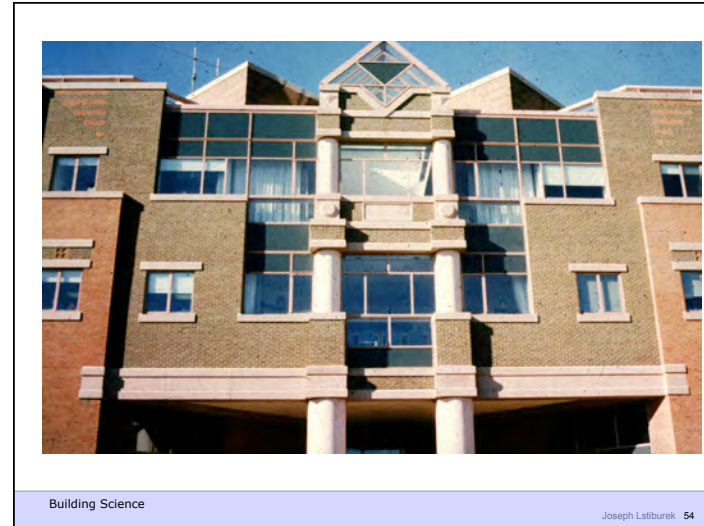



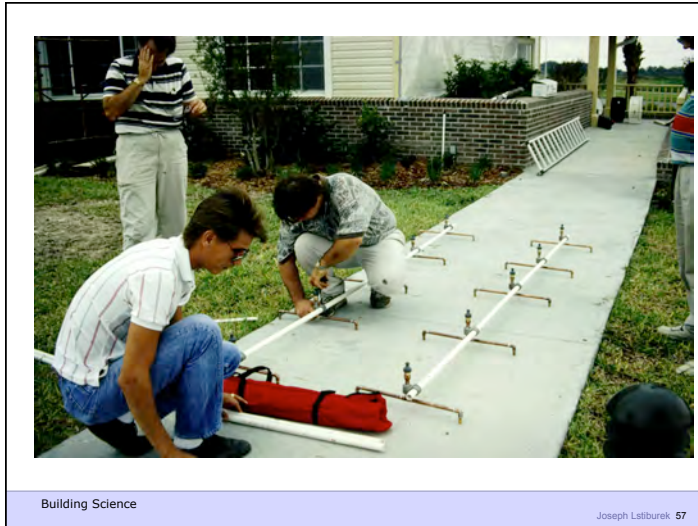



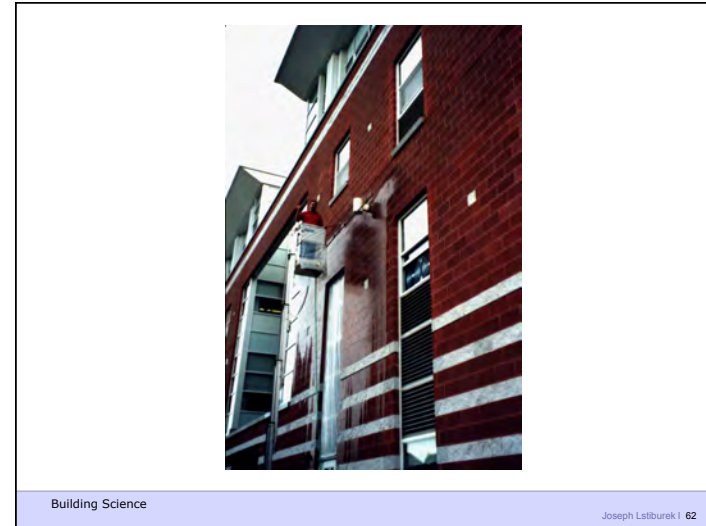
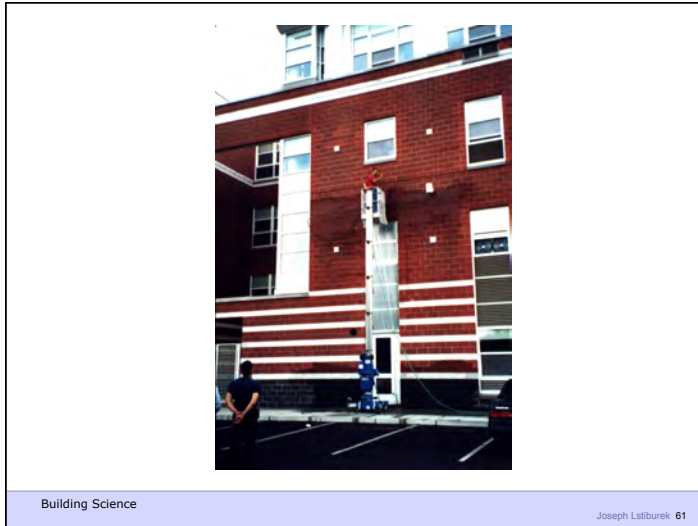



Building Science Corporation

Joseph Lstiburek 65



Building Science Corporation

Joseph Lstiburek 66

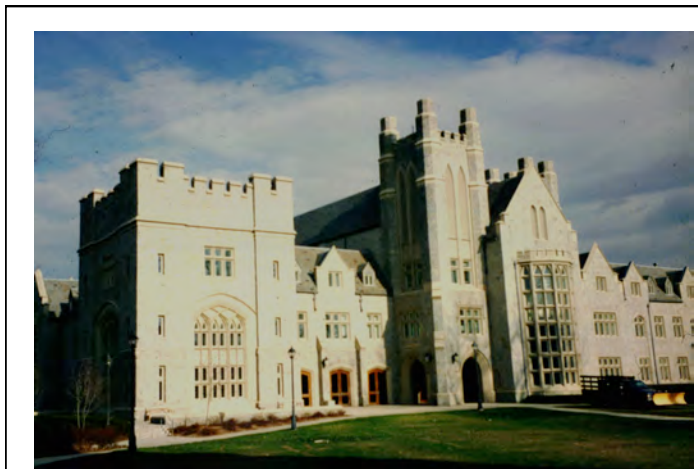

Building Science

Joseph Lstiburek 67



Building Science

Joseph Lstiburek 68

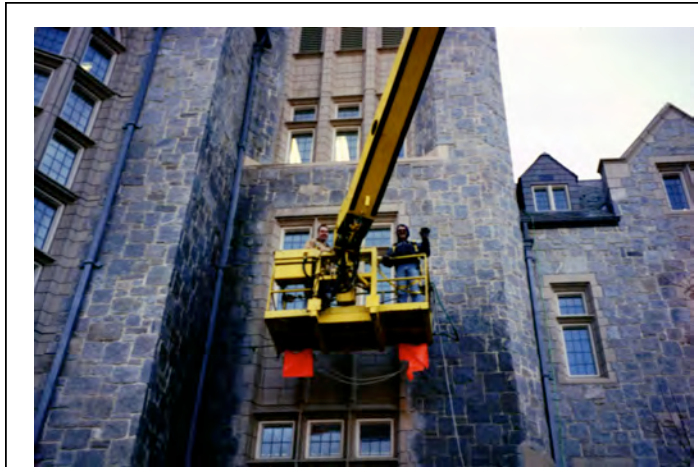

Building Science

Joseph Lstiburek 69



Building Science

Joseph Lstiburek 70

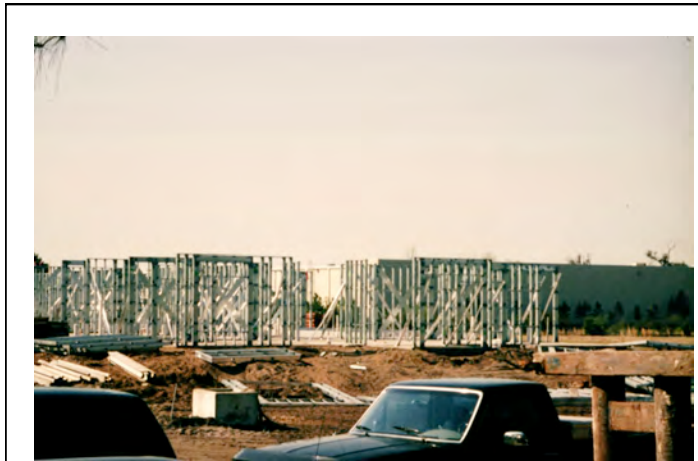

Building Science

Joseph Lstiburek 71



Building Science

Joseph Lstiburek 72



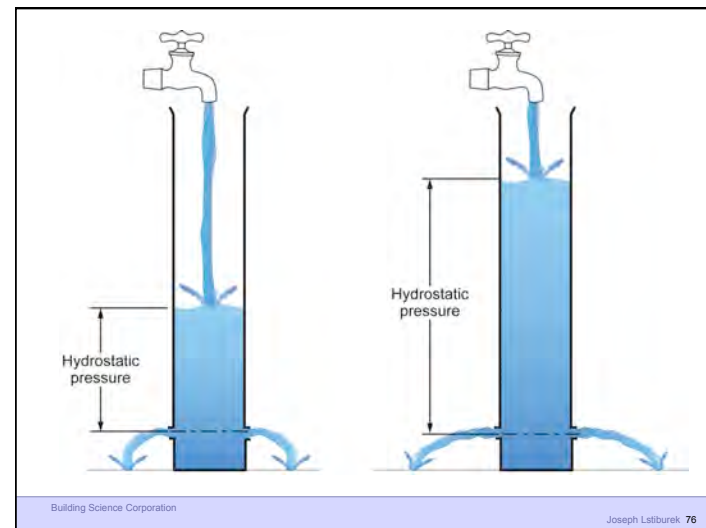
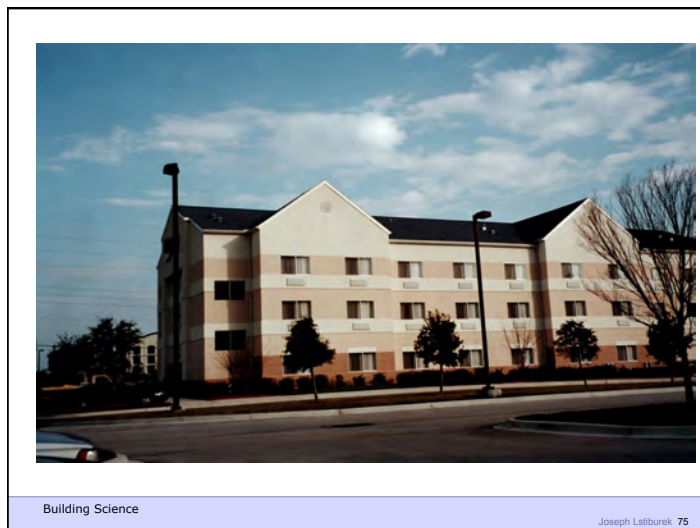
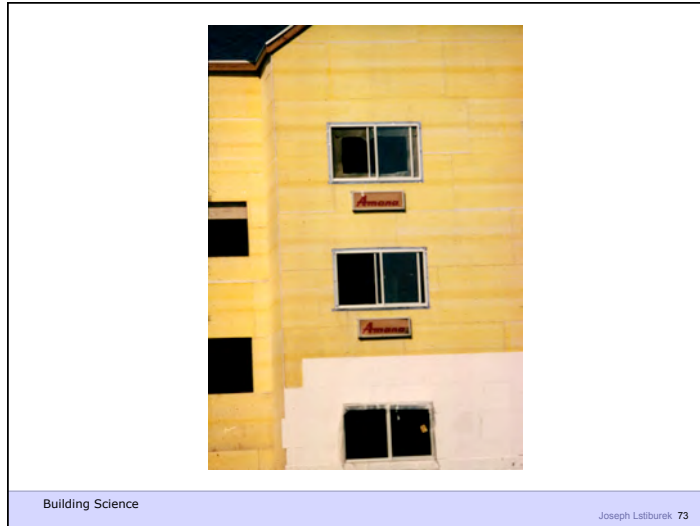

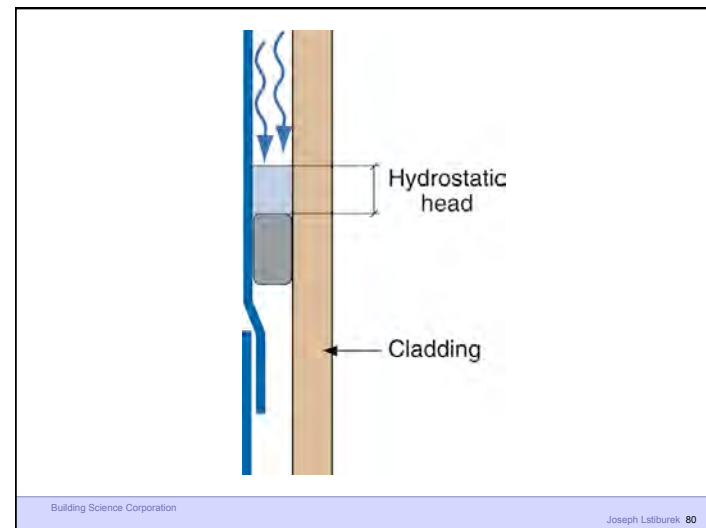
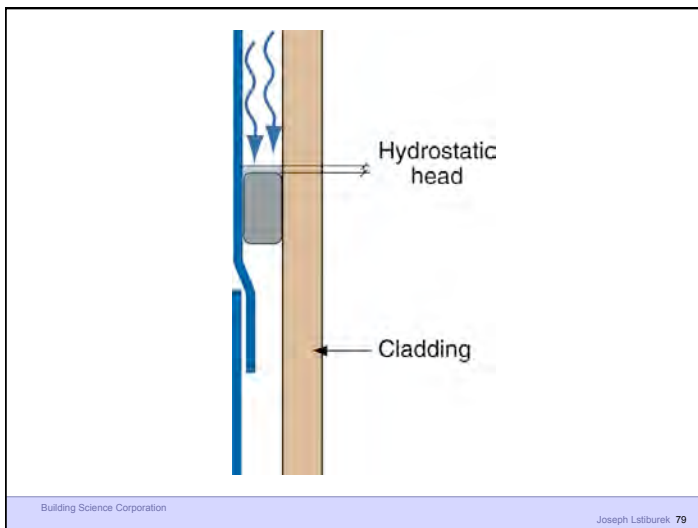
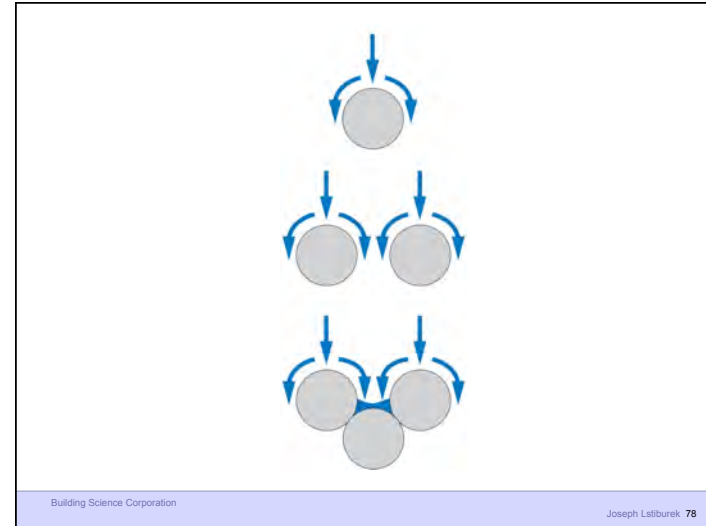
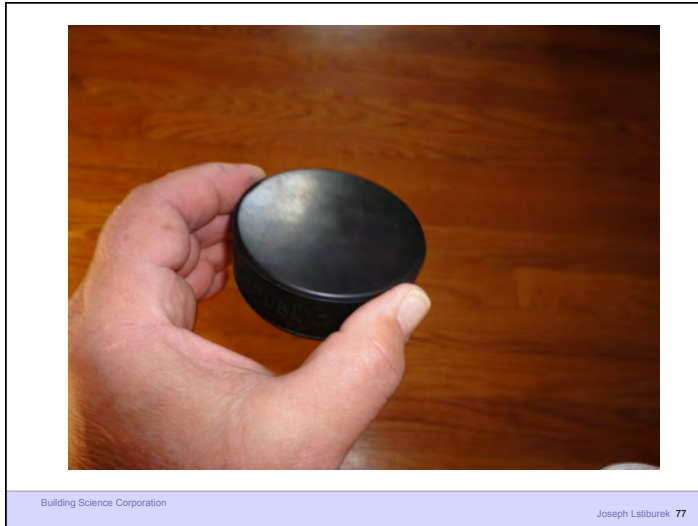

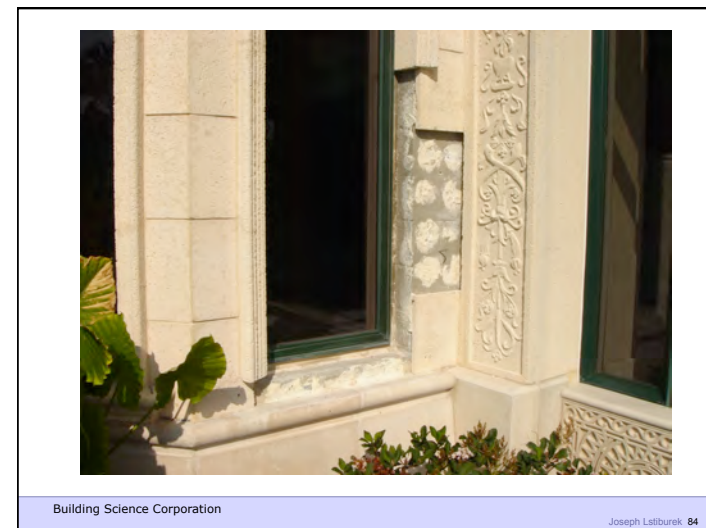
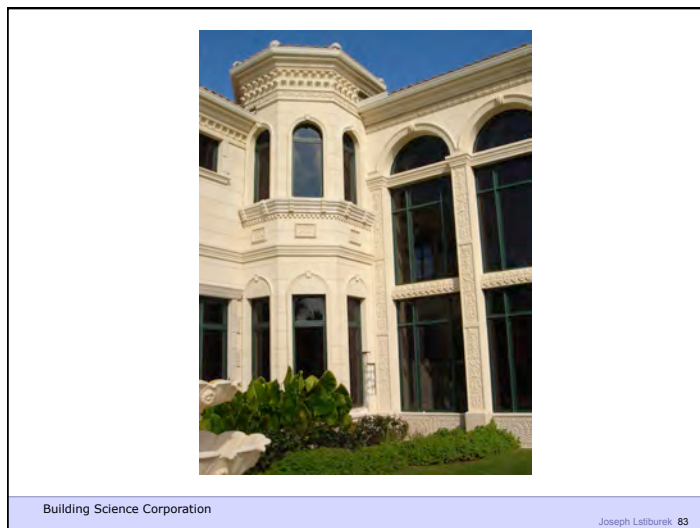
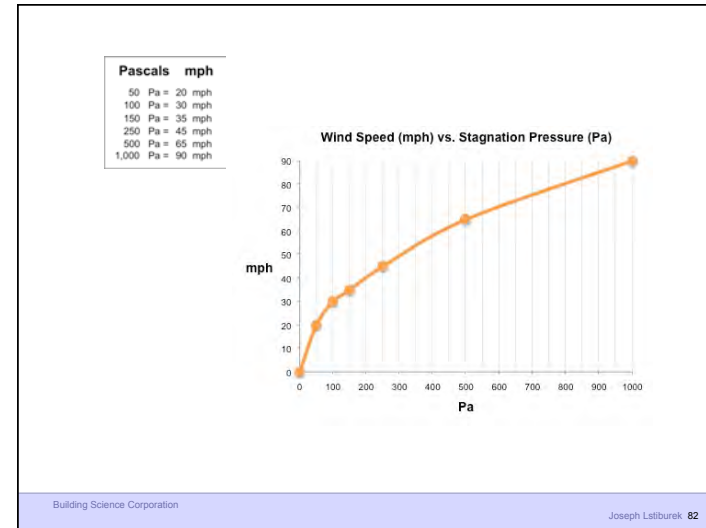
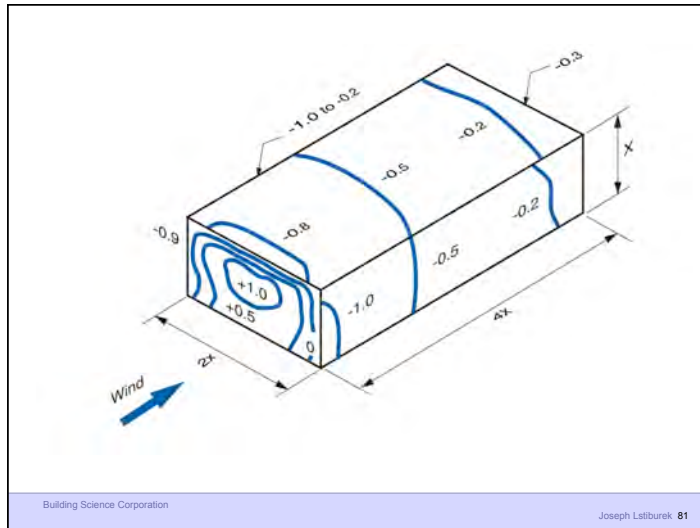





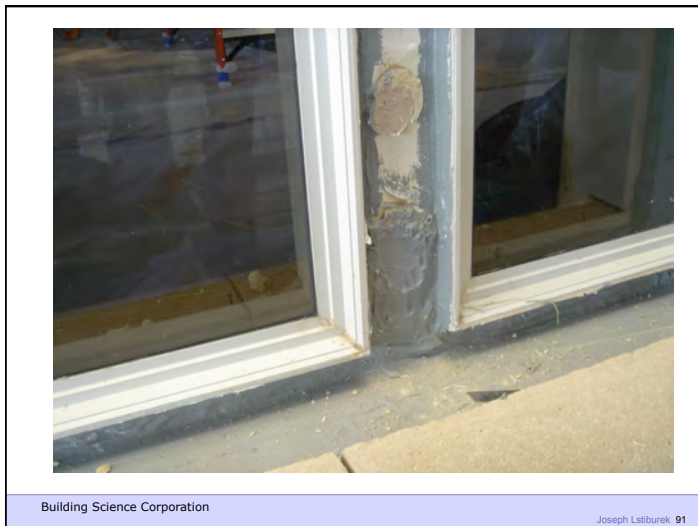
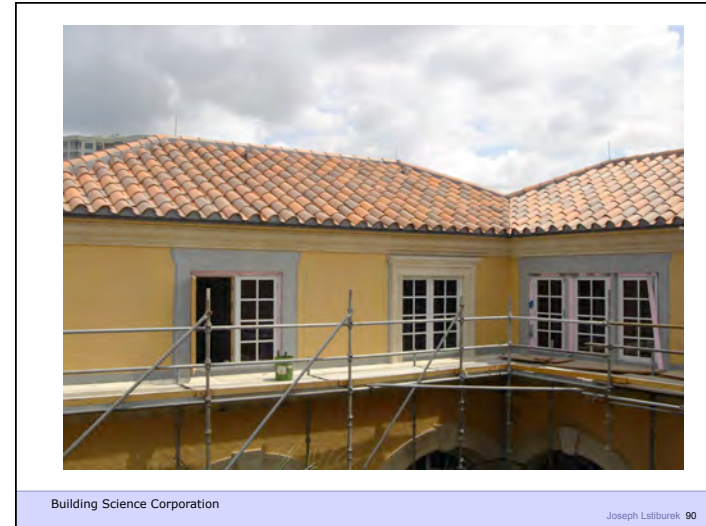

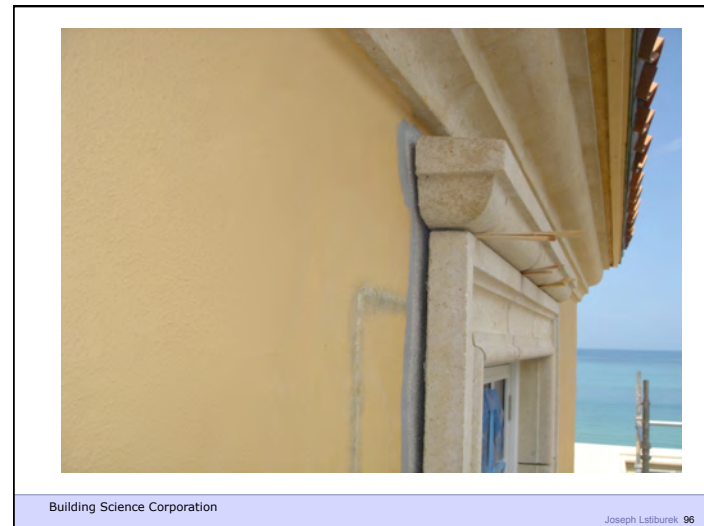
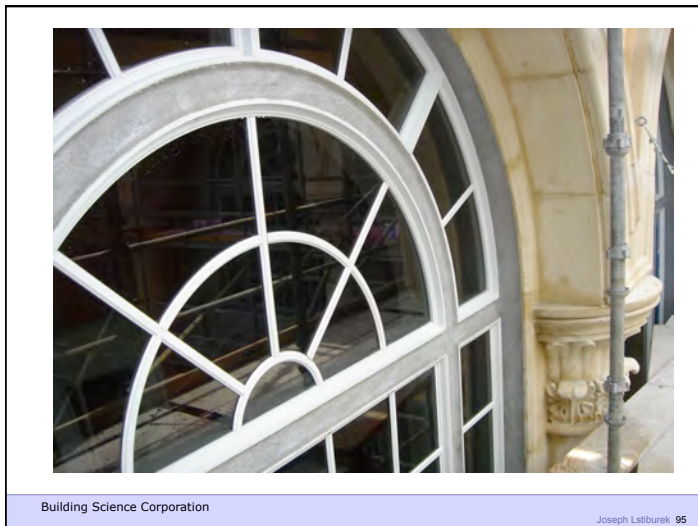
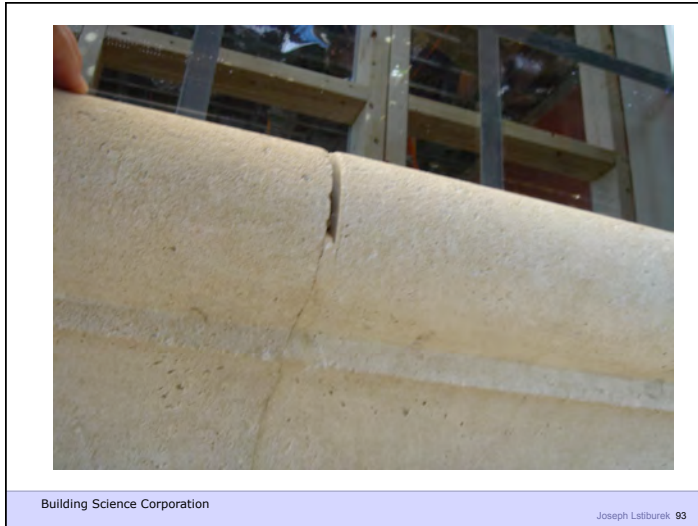

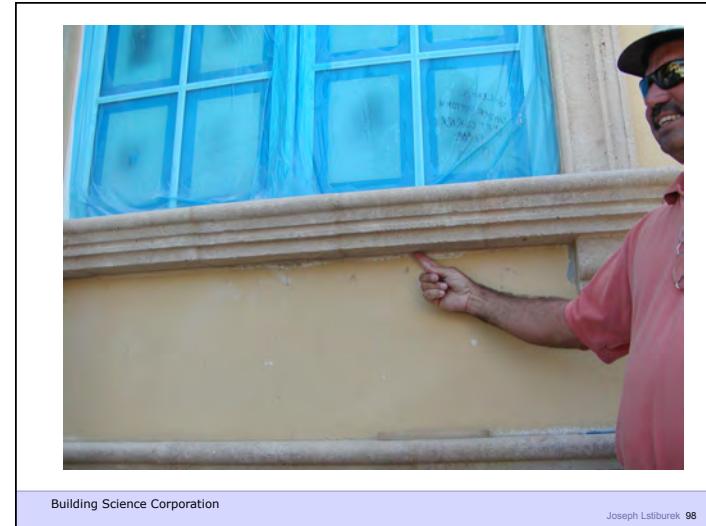



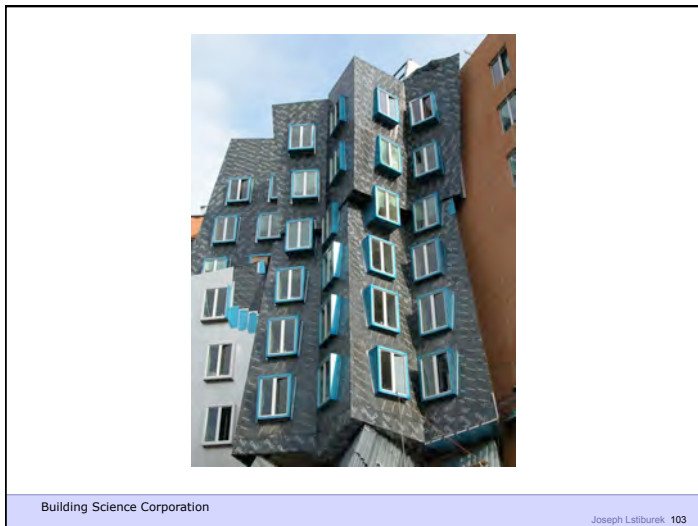
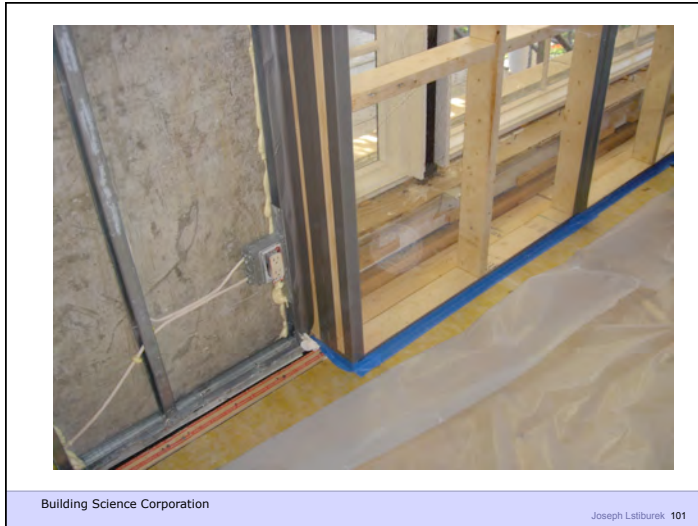

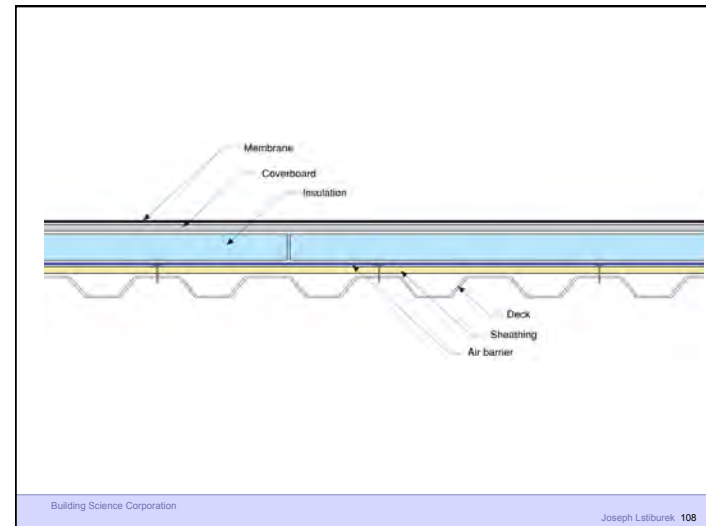
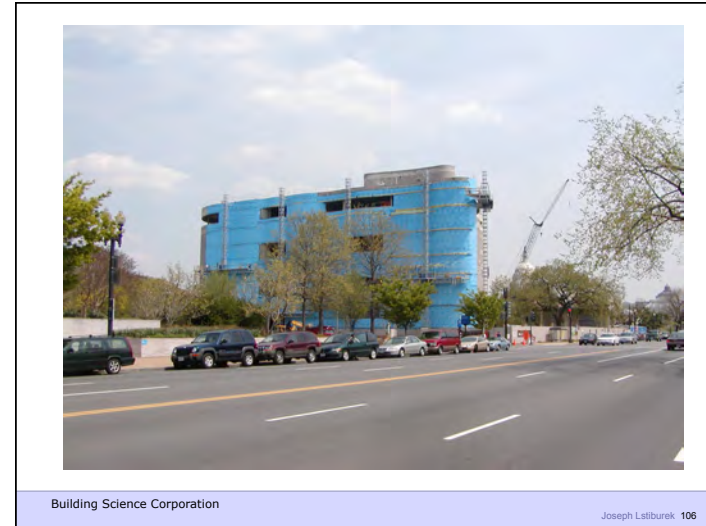
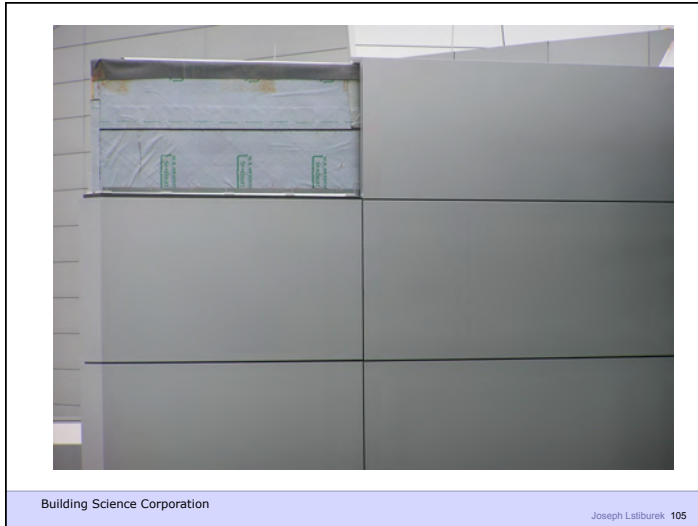

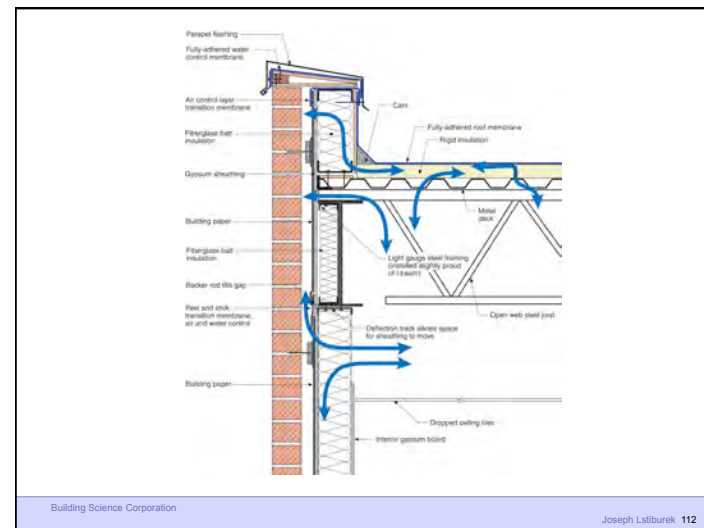
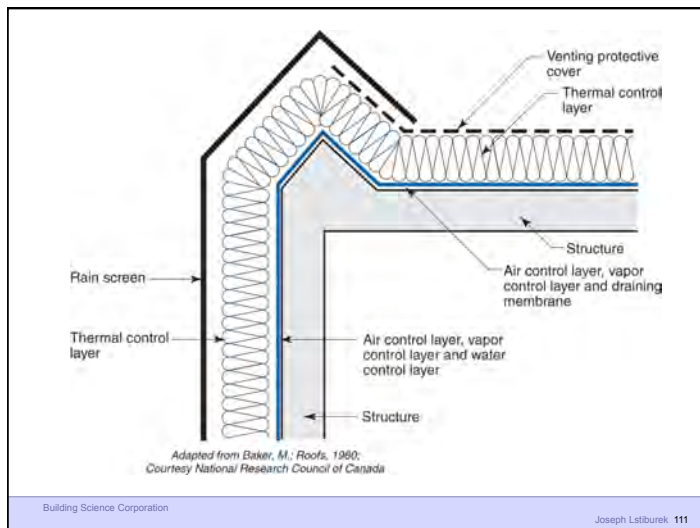
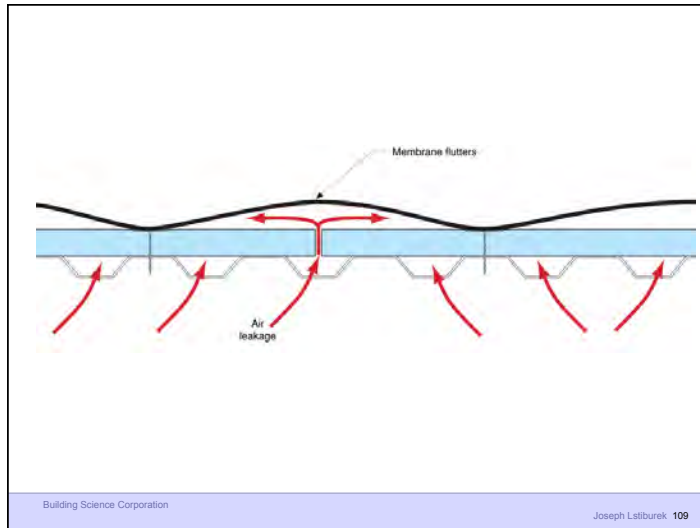



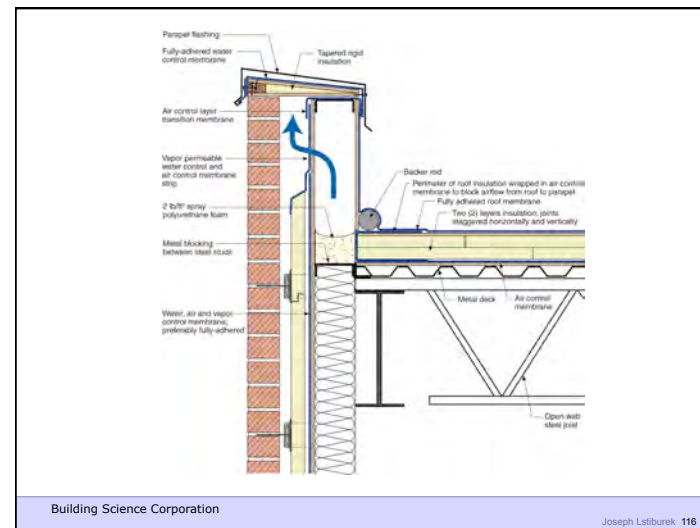
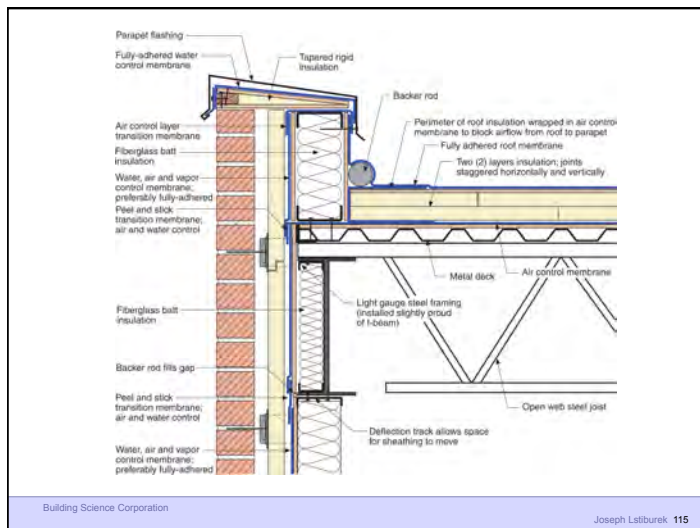
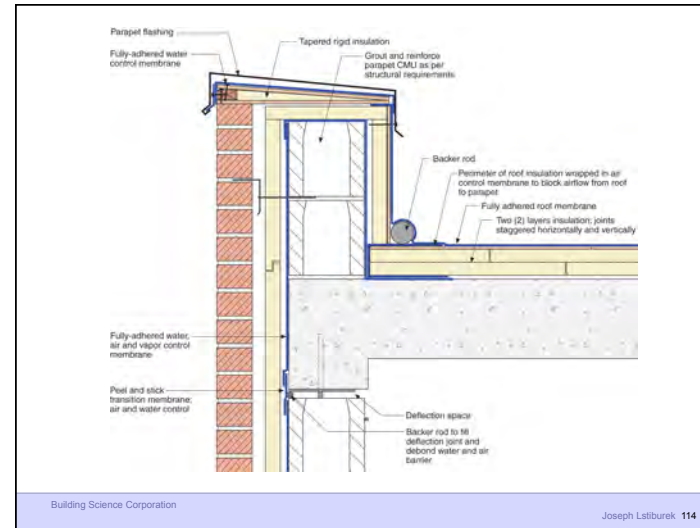
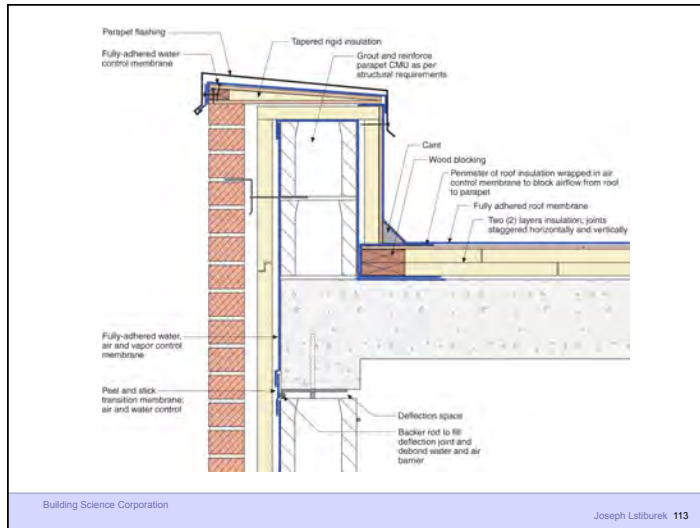



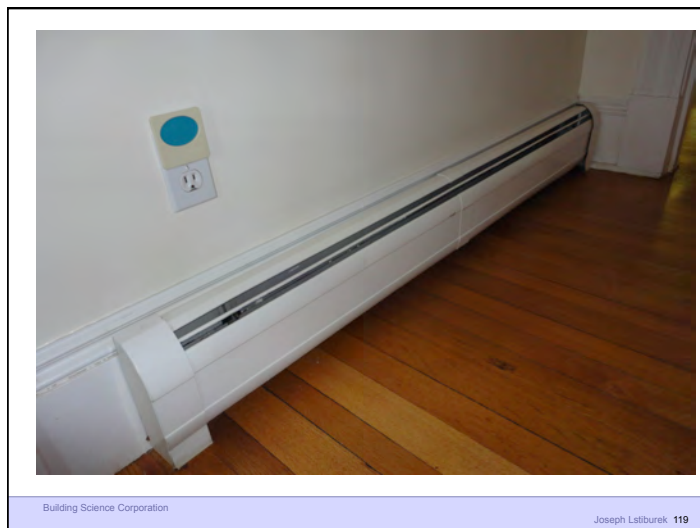
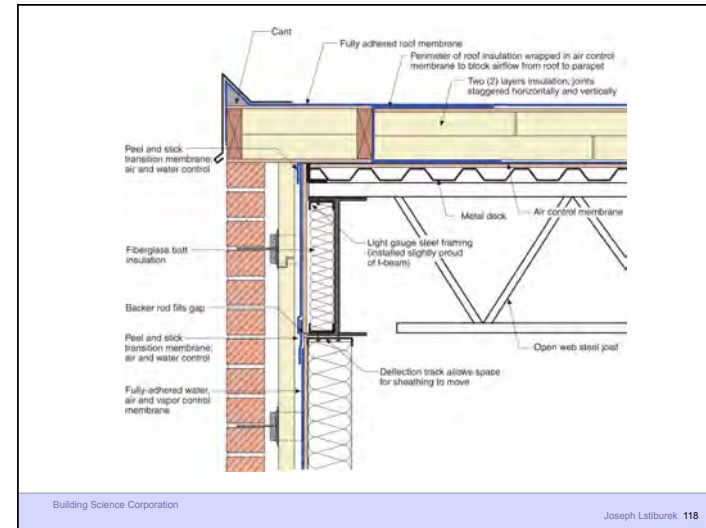
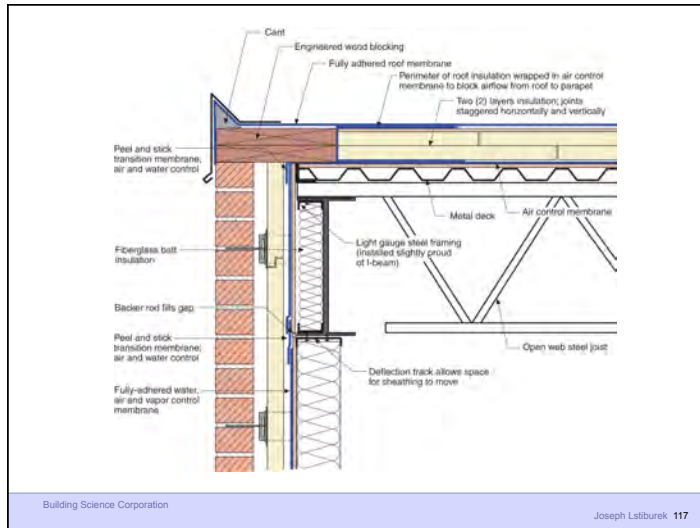

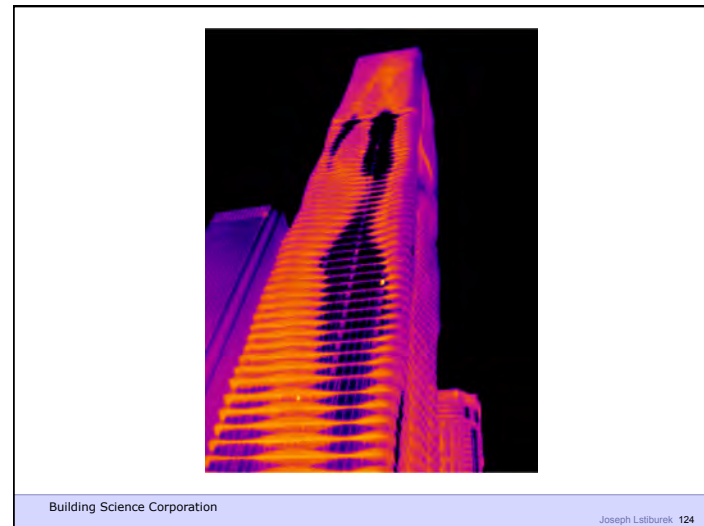
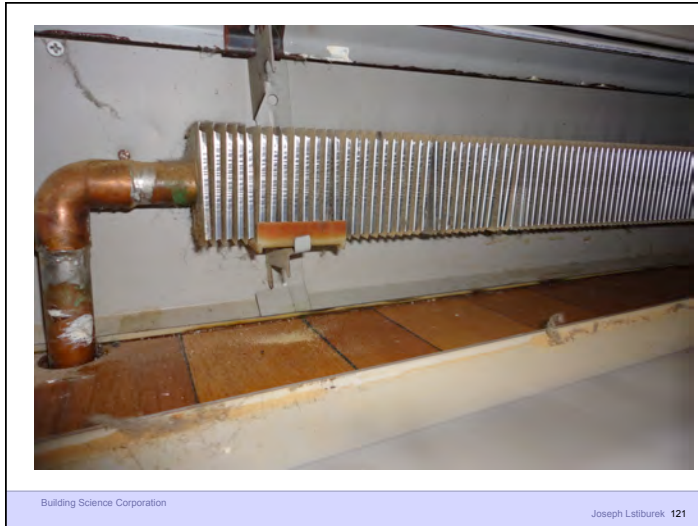

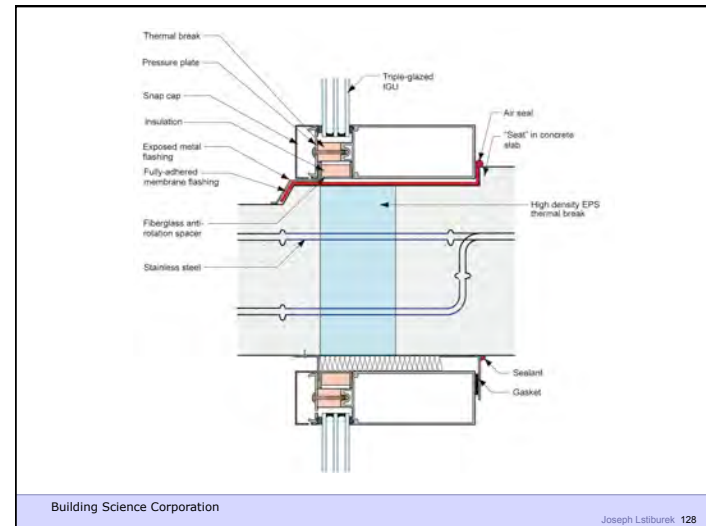
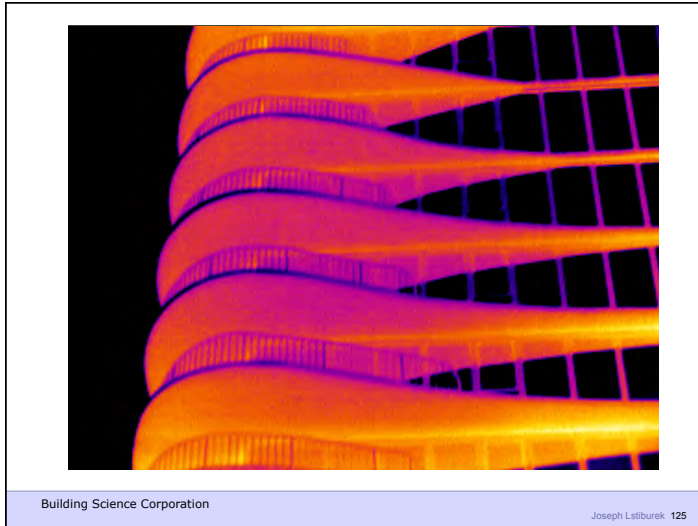



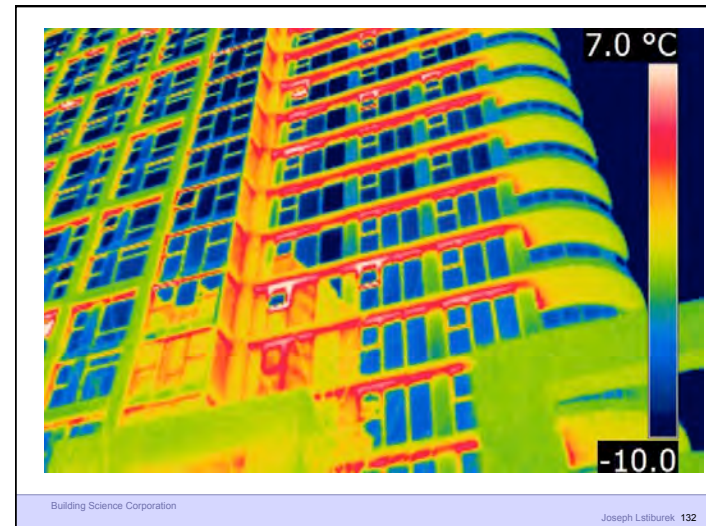
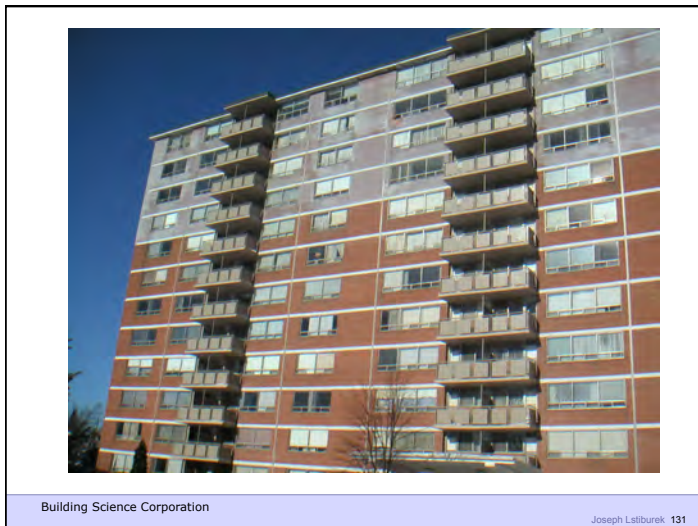

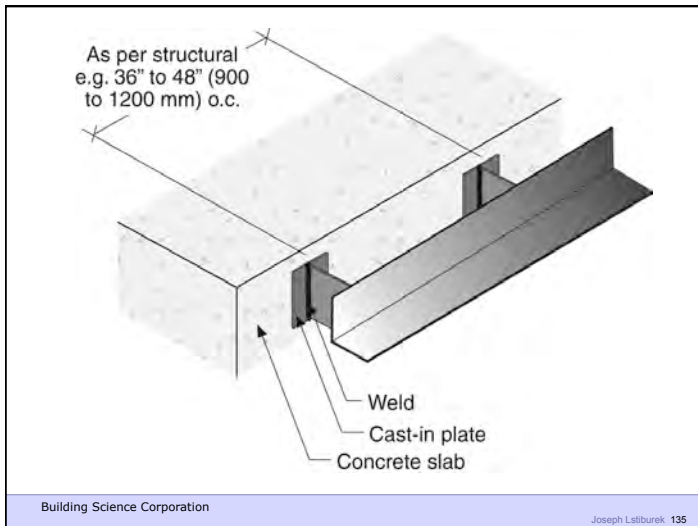
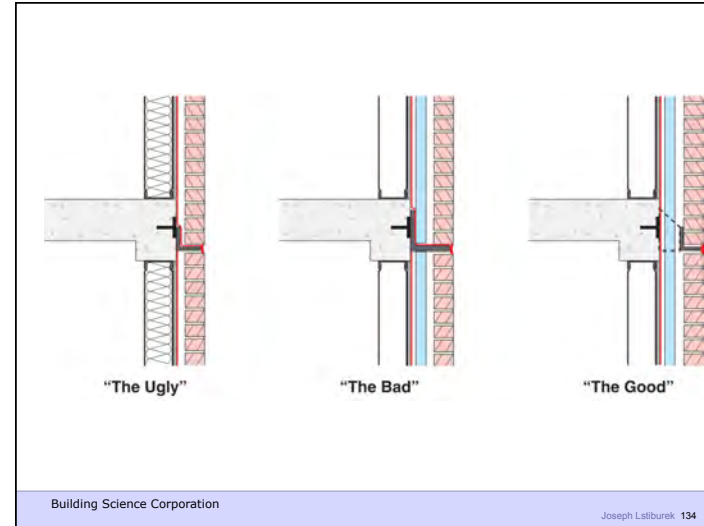

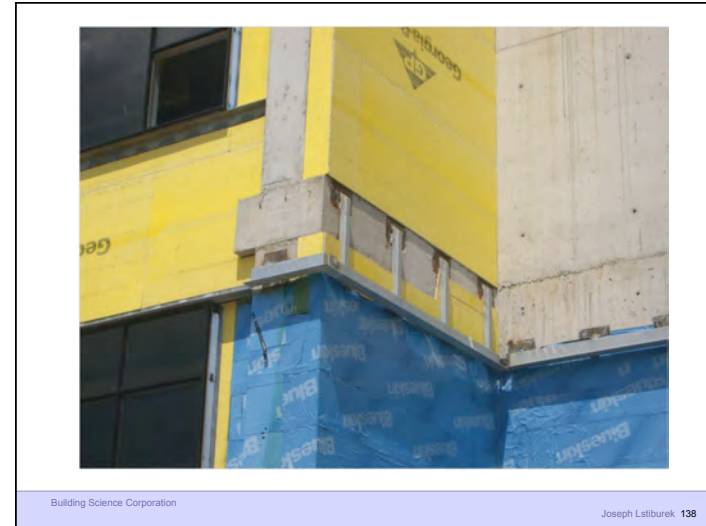

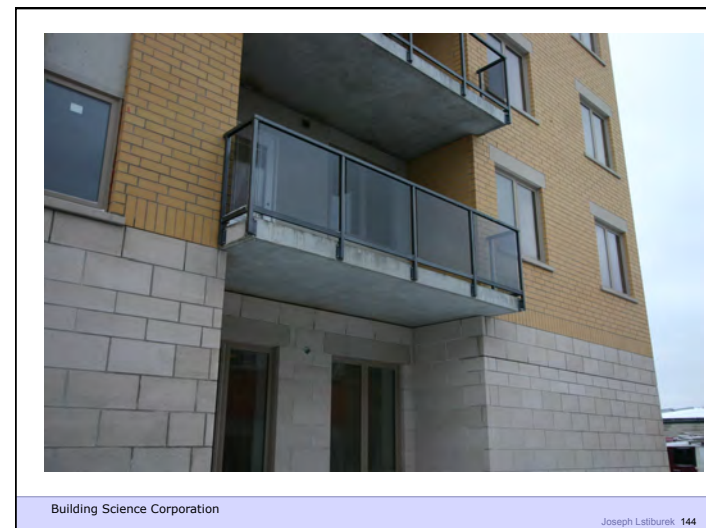
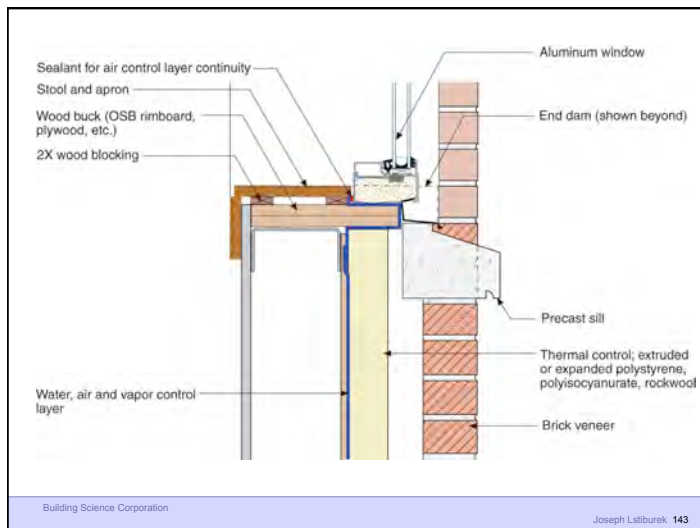
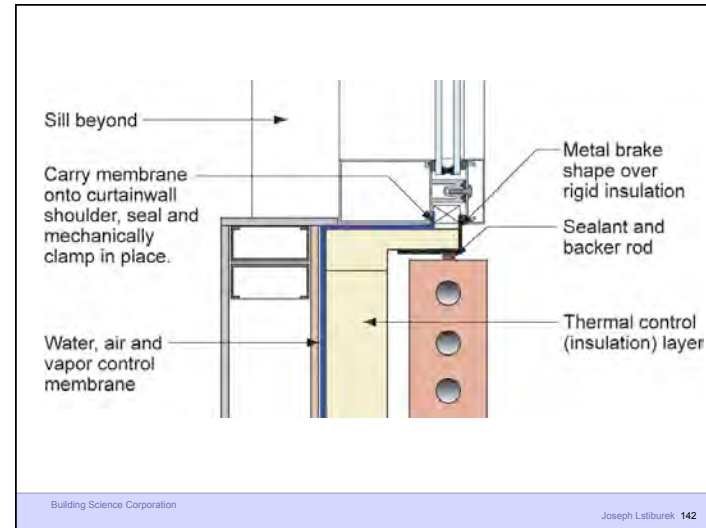
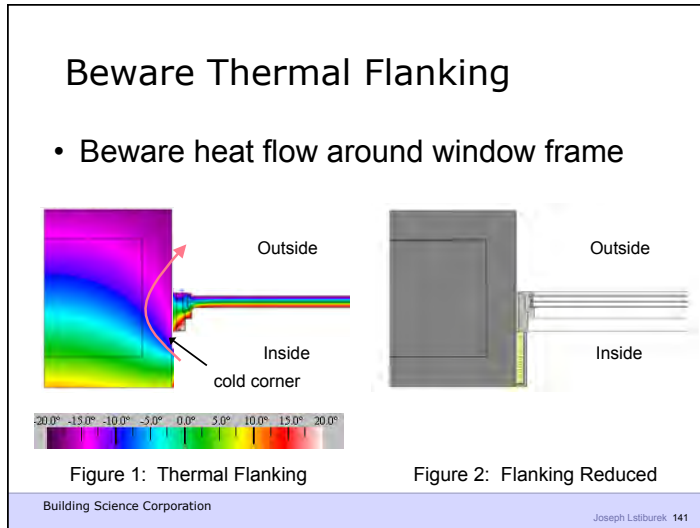



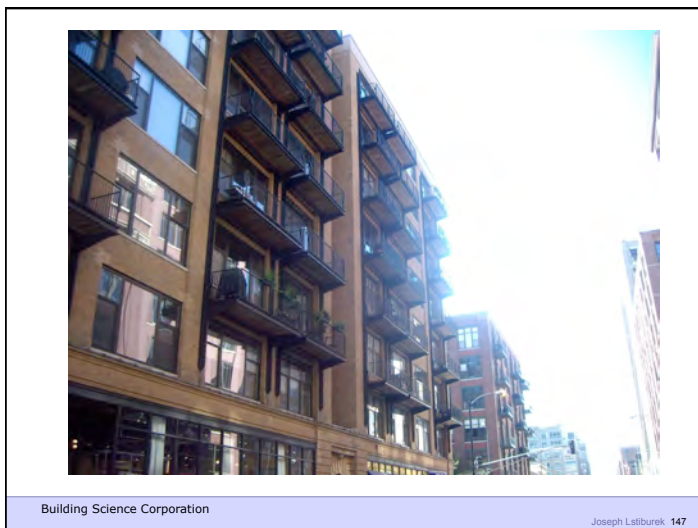

# Peak Oil

Building Science Corporation

Joseph Lstiburek 149

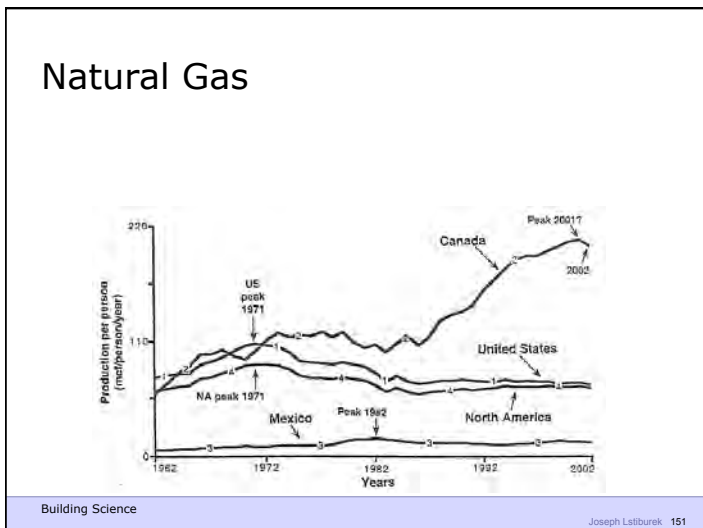
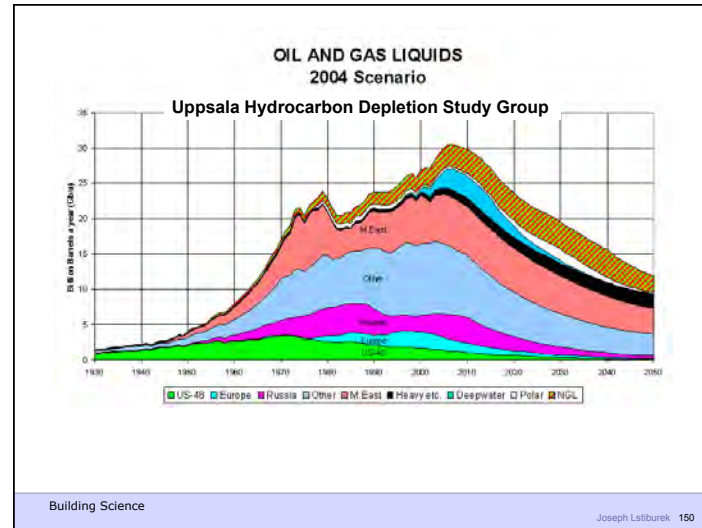

# Boy Were We Ever Wrong.....

Building Science Corporation

Joseph Lstiburek 152

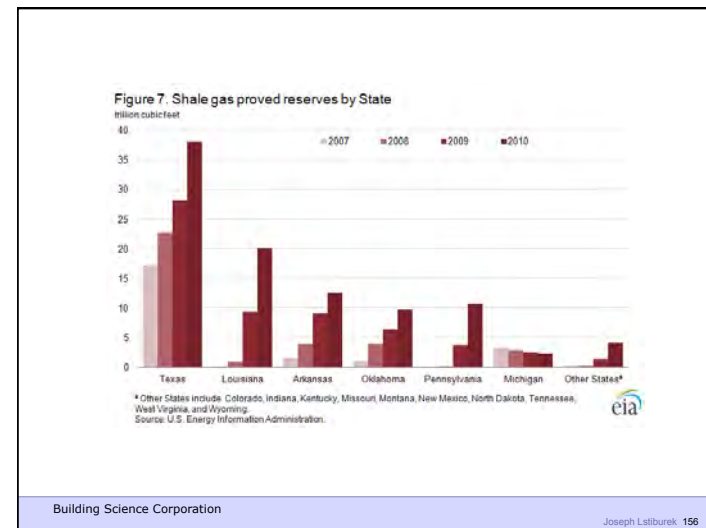
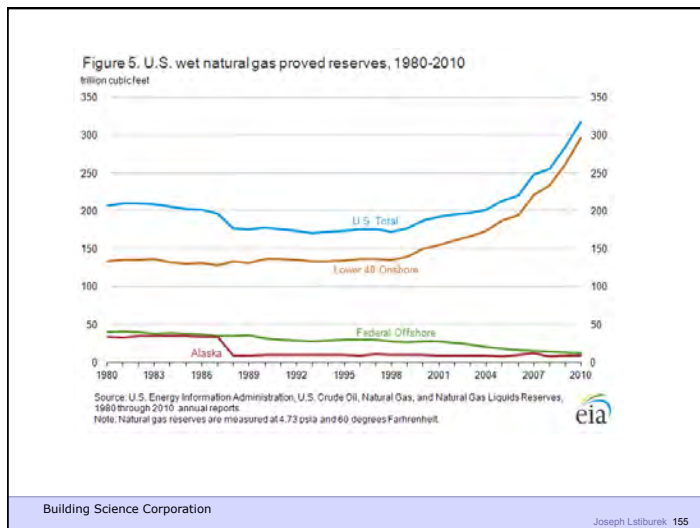
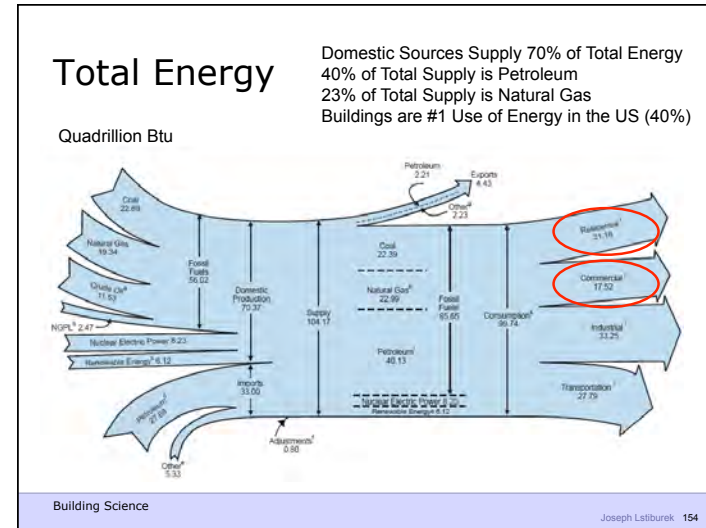
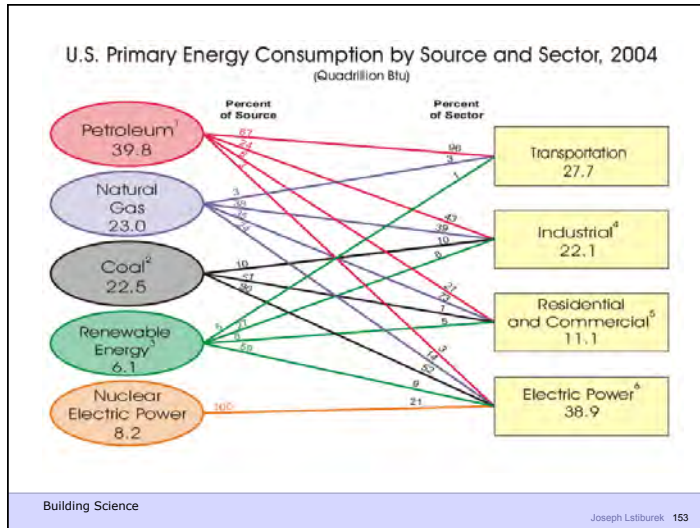

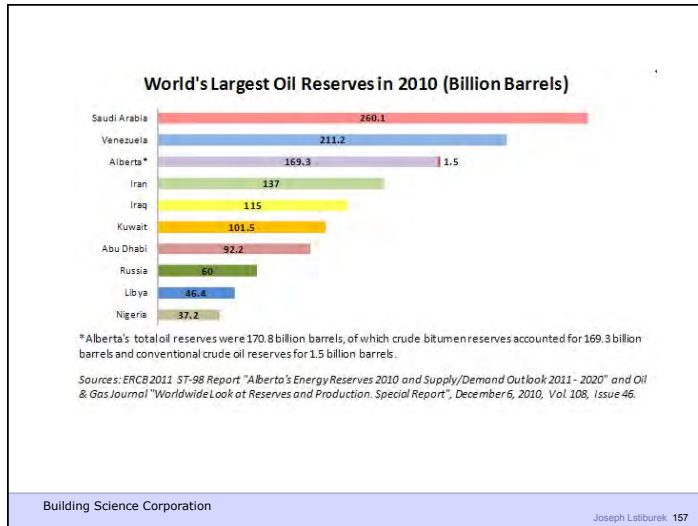

### Oil pipeline through Minn. to be upgraded

Article by DAVID SHAFER, Star Tribune | Updated: October 8, 2012 - 8:39 PM

The line that largely delivers Canadian crude to the Midwest was completed in 2010. Its owner, Enbridge Energy, says more capacity is needed.

[11 comments](#)
[resize text](#)
[print](#)
[buy reprints](#)
[Facebook](#)
[Twitter](#)
[LinkedIn](#)

Hoping to relieve a shipping bottleneck for Canadian and North Dakota oil, Enbridge Energy on Monday filed plans with state regulators to boost capacity by 27 percent on its Alberta Clipper pipeline, which carries crude through northern Minnesota to Superior, Wis.

The project is part of \$600 million in pipeline upgrades in the United States and Canada that Enbridge announced in May to carry more oil from Hardisty, Alberta, to terminals in Wisconsin and Illinois.

In a filing with the Minnesota Public Utilities Commission, Enbridge said it will spend \$40 million to upgrade three Minnesota pumping stations, at Viking, Clearbrook and Deer River, allowing them to push more oil through the 36-inch Alberta Clipper pipeline.

"This project will increase the pipeline capacity ... in order to meet North America's growing need for reliable transportation of crude oil supplies from growing production regions in Western Canada and North Dakota and surrounding regions," Enbridge said in its filing.

Building Science Corporation Joseph Lstiburek 159

# Climate Change

Building Science Corporation Joseph Lstiburek 160



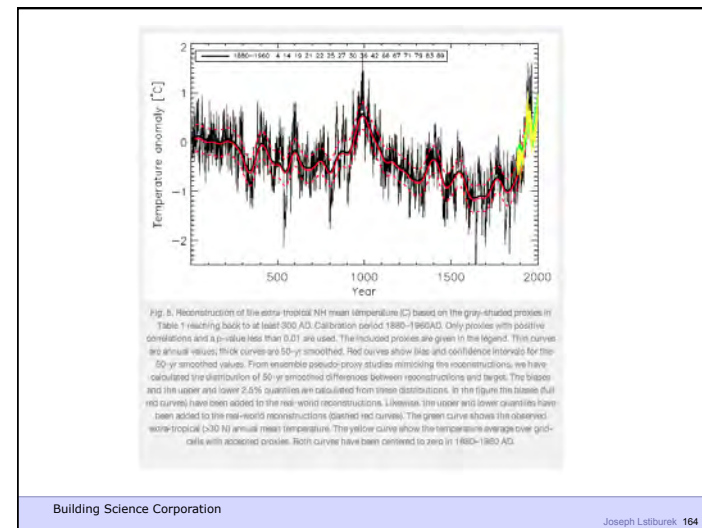
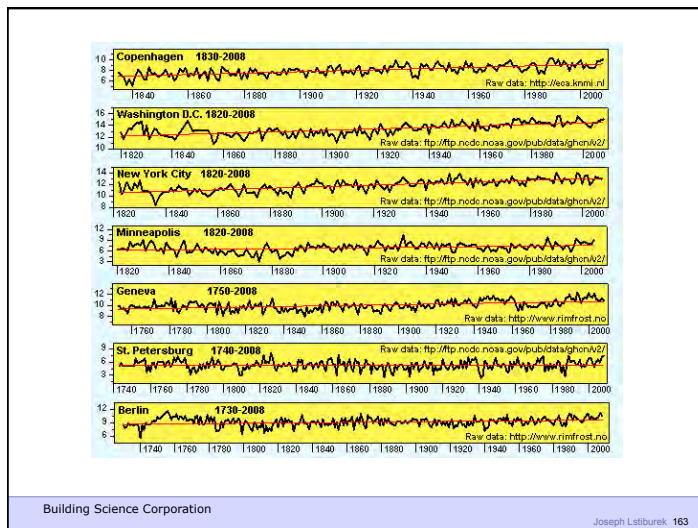
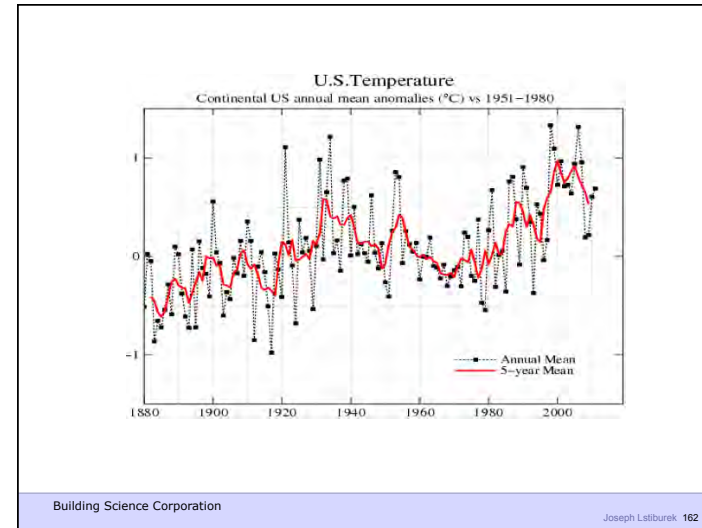
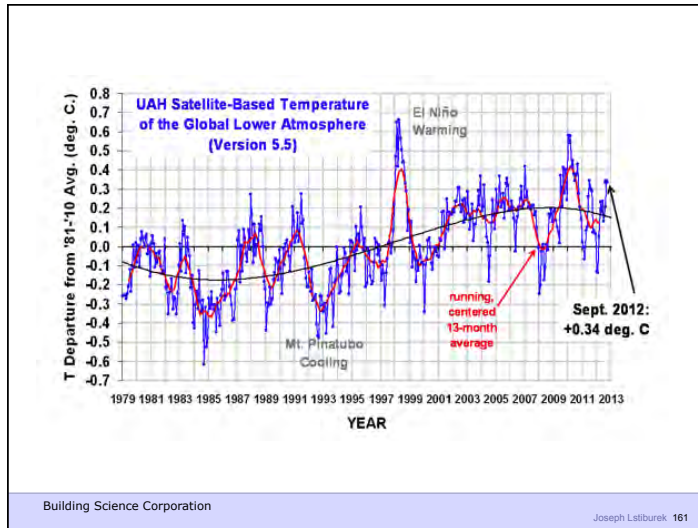

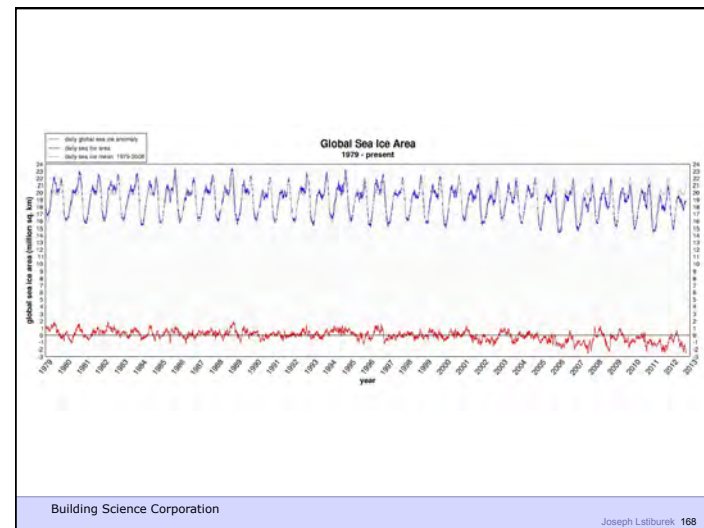
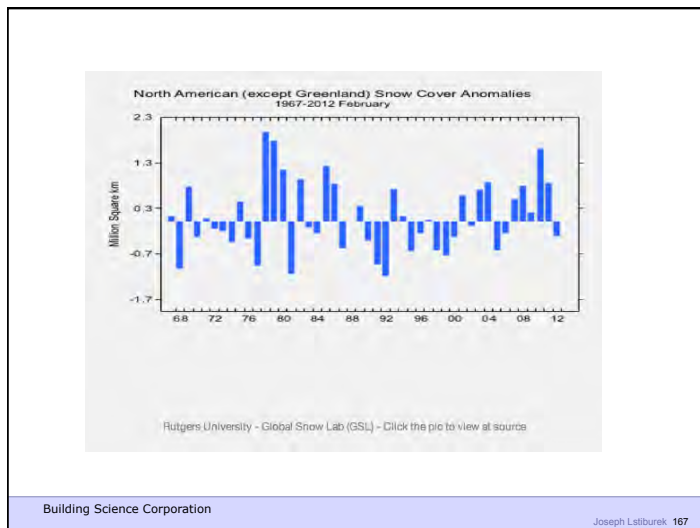
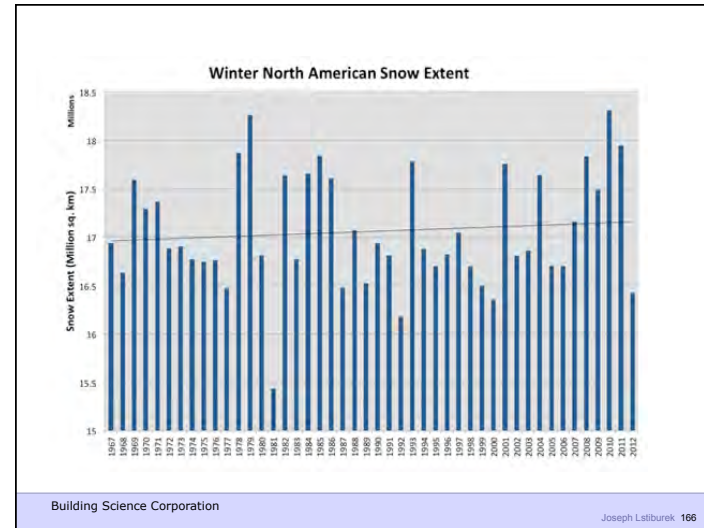
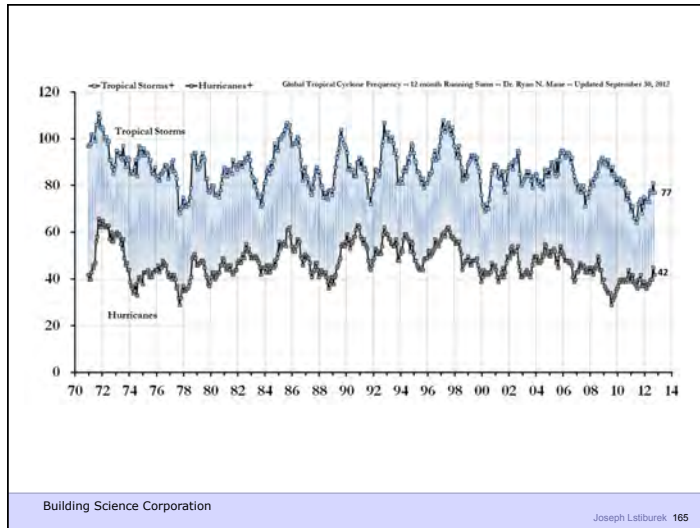

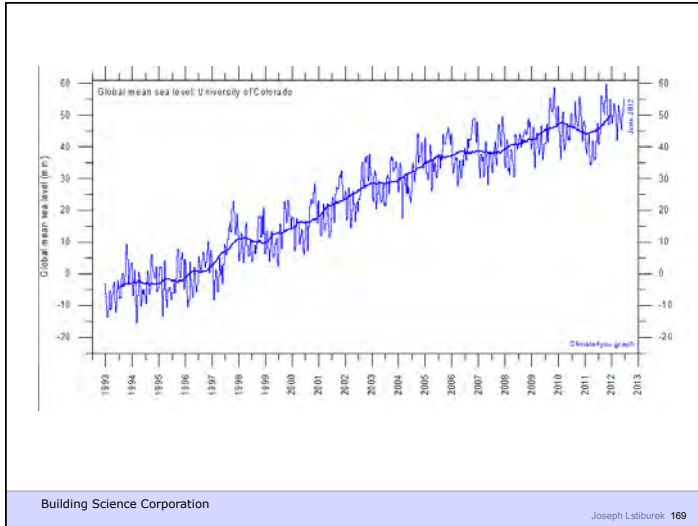

Climate Has Always Been Changing

Joseph Lstiburek 170

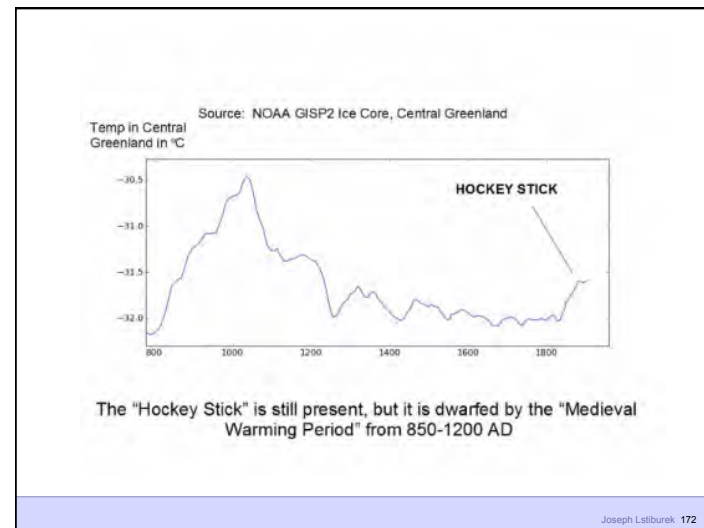
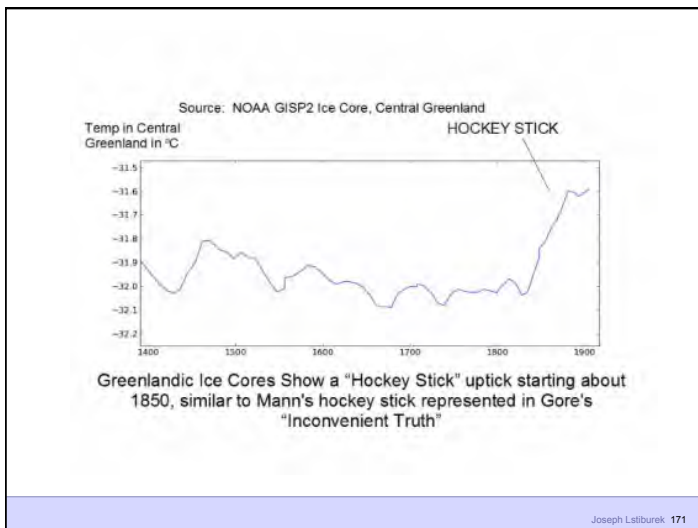

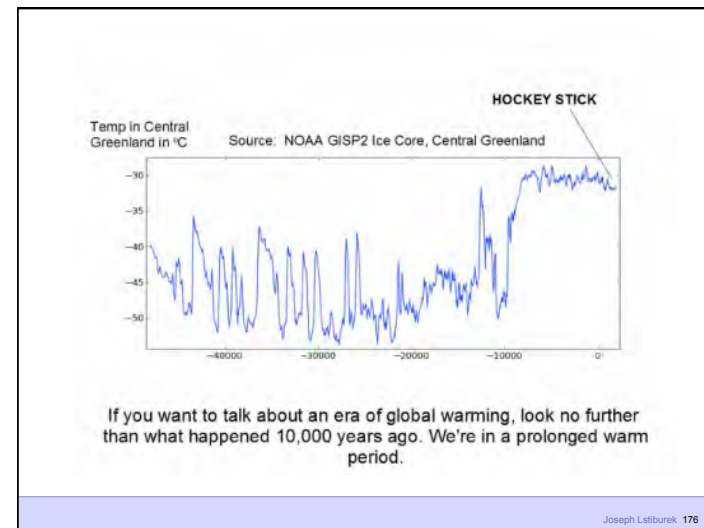
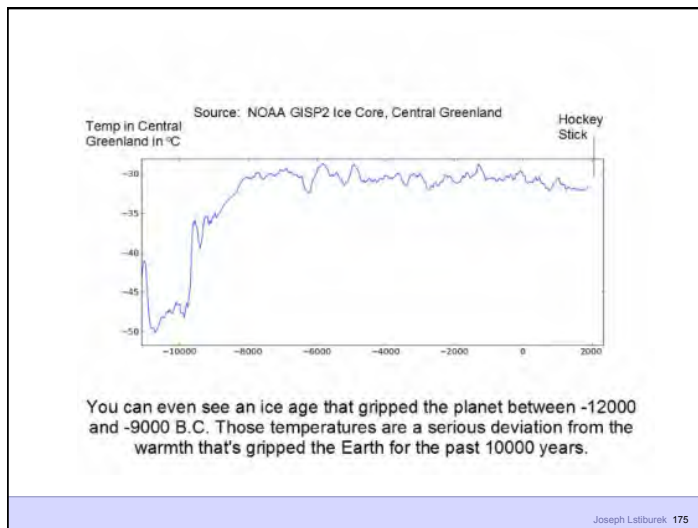
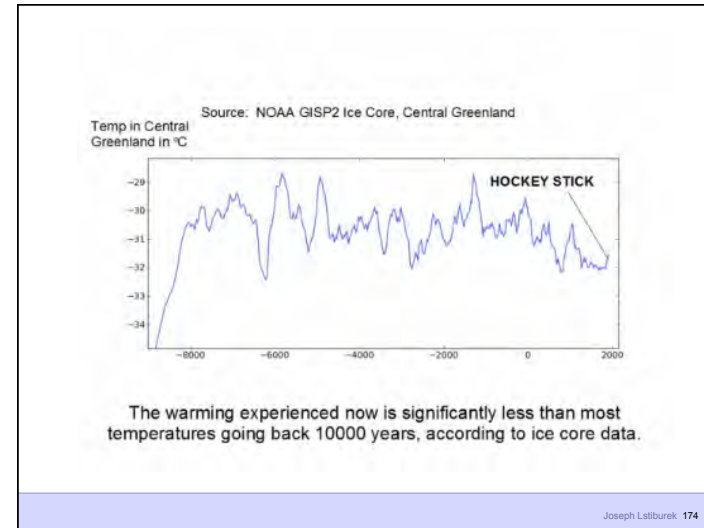
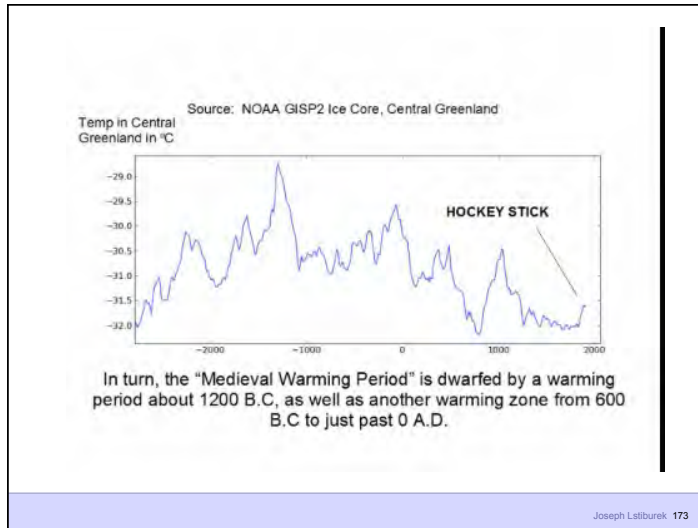



Milankovich Cycles  
 Planetary Motion  
 Thermohaline Circulation (SST)  
 Solar Irradiance

Joseph Lstiburek 177

Milankovich Cycles  
 Eccentricity - periodicity 100,000 years  
 Axial Tilt - periodicity 41,000 years  
 Precession - periodicity 23,000 years

Joseph Lstiburek 178

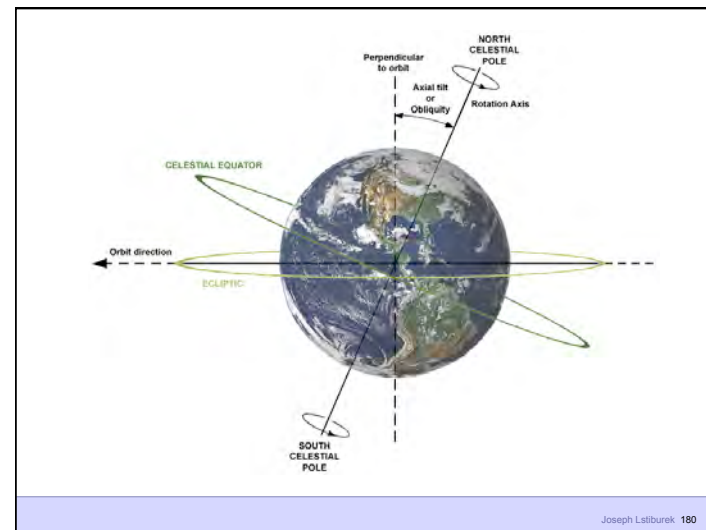
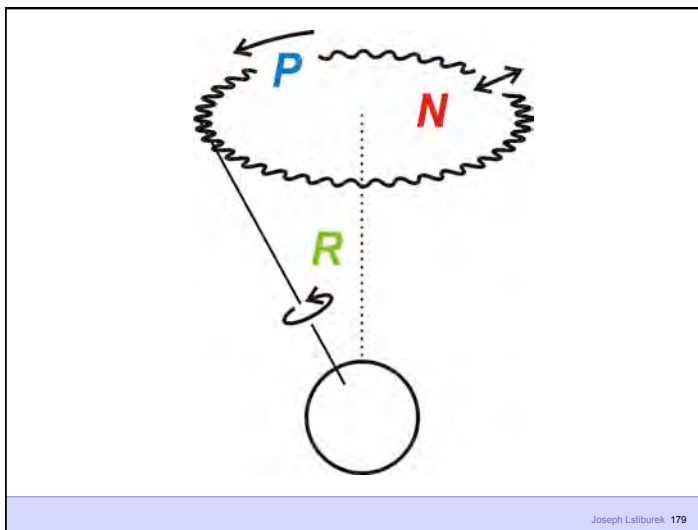

Thermohaline Circulation (SST)  
 Sea Surface Temperature (SST) Field  
 Pacific Decadal Oscillation (PDO)  
 El Nino Southern Oscillation (ENSO)  
 Atlantic Multidecadal Oscillation (AMO)

Joseph Lstiburek 181

Thermohaline Circulation (SST)  
 PDO - 20 to 30 year cycles  
 AMO - 70 year cycles  
 ENSO - 3 to 8 year cycles

Joseph Lstiburek 182

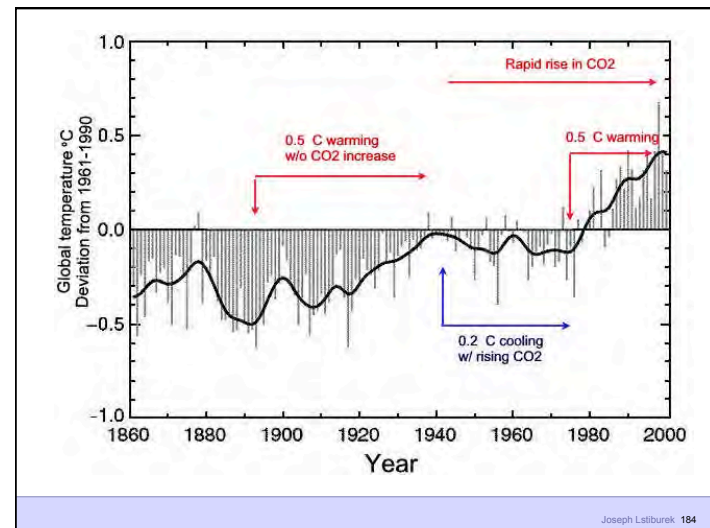
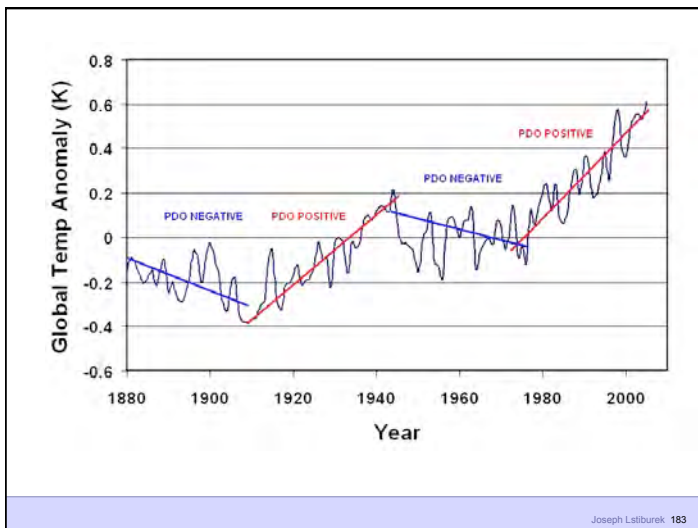

Renewables

Building Science Corporation Joseph Lstiburek 185



Building Science Corporation Joseph Lstiburek 186



Building Science Corporation Joseph Lstiburek 187

Peak Green

Building Science Corporation Joseph Lstiburek 188

Renewables Lose  
Conservation Wins  
Green is a Fad  
And Carbon Does Not Matter  
Enjoy the Moment

Building Science Corporation

Joseph Lstiburek 189