

Air Sealing Rim Closure Penetrations

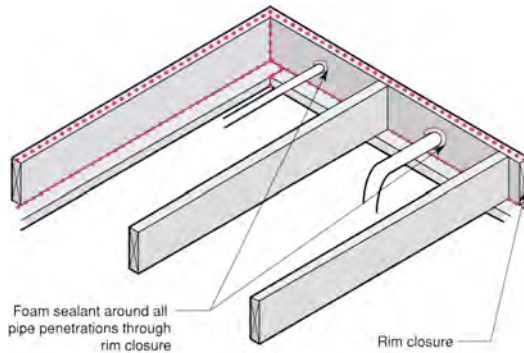

- Penetrating pipes, conduits, ducts, projecting beams etc, are sealed to the air barrier element that they penetrate.

Air Sealing at Vertical Plumbing Penetrations

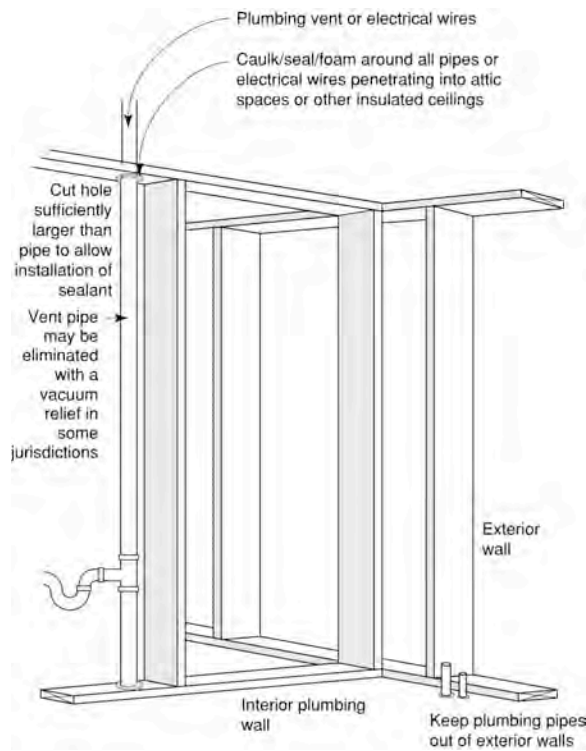

- Plumbing penetrations through the floor plane are sealed either to the subfloor or to the bottom plate.
- Penetrations through the top plate must also be sealed if the top plate is in the plane of an intended air, smoke or fire separation

Sealing Air Barrier Penetrations

Most air barrier systems will require supplemental air sealing to seal around penetrations. Typical penetrations through the primary components of the air barrier system include plumbing pipes and vents, electrical wires and conduits, electrical fixtures, other mechanical services, and, in some cases, structural members.

Penetrations through Rain Shedding Assemblies

Penetrations through building enclosure elements that also perform rain water management functions must be properly flashed. It is critical that air sealing not interfere with drainage (see Information Sheet 302, and 303).

Typical Plumbing Penetrations within the Building Enclosure

Vertical plumbing runs are typically sealed at the floor plane or bottom plate for floors over unconditioned space or over a separate dwelling unit. While holes to accommodate pipes, conduits and wires represent potential breaches in the air barrier, serious lapses can result from utility chases. Utility chases must be draftstopped wherever these intersect an intended air barrier plane. In colder climates this is also an important freeze-protection measure. Diagrams on the following page illustrate measures to draftstop the utility chase.

While plumbing should not be located in exterior walls, demising walls (or party walls) represent a situation where plumbing may penetration an air barrier assembly laterally. Demising walls should be constructed as airtight assemblies for reasons of sound, smoke, fire and air quality control. Therefore, any penetrations through the drywall surface of demising walls should be sealed air tight. Ensure that the sealant material used complies with any required fire resistance rating and that it is compatible with the pipe, conduit or wire materials.

Sealing penetrations for sprinkler heads requires special attention as the air sealing must not interfere in anyway with operation of the fire suppression system. The air seal should be between the pipe and the air barrier, not between the sprinkler head itself and the air barrier.

Typical Electrical Penetrations within the Building Enclosure

Vertical wiring or conduit runs are typically sealed at the floor plane or bottom plate for floors over unconditioned space or over a separate dwelling unit (i.e., similar to vertical plumbing runs described above). Holes to accommodate electrical services must also be sealed where interior partitions intersect an exterior wall or demising wall.

Typical penetrations in exterior wall, demising wall and ceiling drywall assemblies include electric penetrations – electric boxes and recessed fixtures.

Electric boxes can be made air tight by caulking or sealing all openings in the box (including around wire penetrations) and by sealing the face of the box to the drywall. Specially designed airtight electric boxes with flexible boot seals at wire penetrations and a gasketed flange at the face can also provide air barrier continuity.

Gasketed Electric Box



Draftstop of Utility Chase at Exterior Wall or Demising Wall

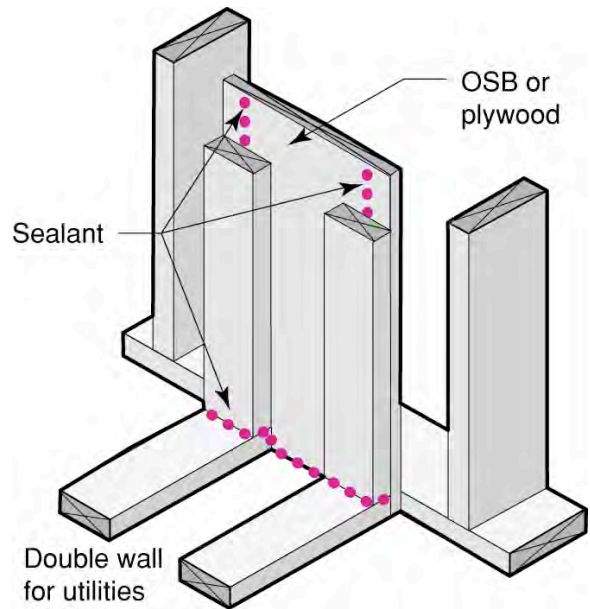

- Solid draftstop material sealed to framing to isolate utility chase cavity

Utility Chase at Insulated Ceiling

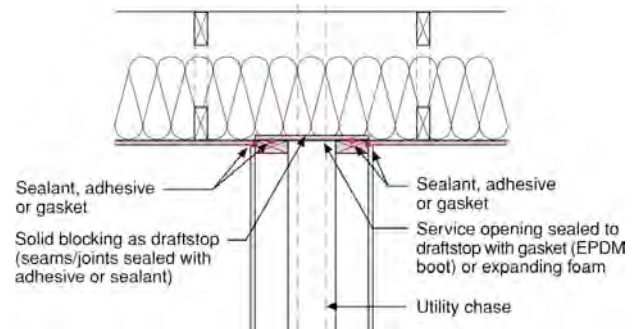

- Flexible gasket sealed to top plate or other solid blocking allows movement of penetrating element without losing the air seal

Recessed ceiling fixtures in insulated ceiling should be both insulation contact (“IC”)- and air tight rated. The housing of the recessed fixture should also be sealed (with caulk or an effective gasket) to the ceiling gypsum board.

Interior soffits that are not constructed entirely inside of the air barrier may result in lapses in the air barrier if not treated properly. In terms of air barrier performance, such soffits are similar to utility chases: they must be thoroughly draftstopped wherever these intersect an intended air barrier plane.

Interior Soffit at Ceiling Air Barrier

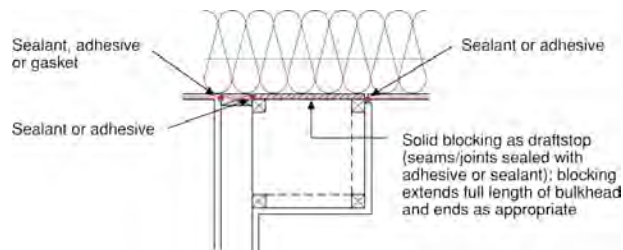

- Solid draftstop material is sealed to framing and surrounding air barrier material.
- Alternatively, the soffit may be constructed after the sealing gypsum board is installed and sealed

Interior Soffit at Exterior or Demising Wall

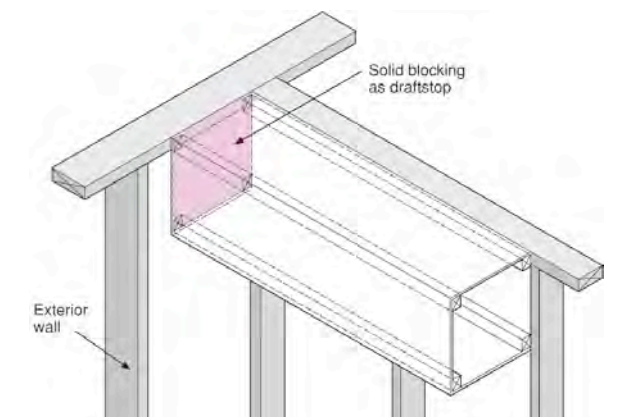

- Solid draftstop material is sealed to framing and surrounding air barrier material.
- Alternatively, the soffit may be constructed after the sealing gypsum board is installed and sealed

Plumbing Penetration through Top Plate with Unconditioned Space Above

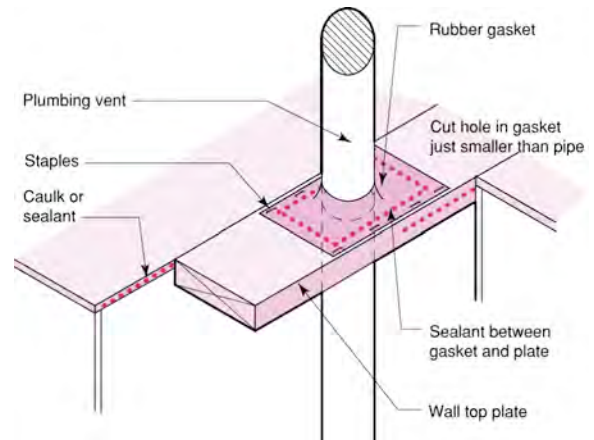

- Flexible gasket sealed to top plate or other solid blocking allows movement of penetrating element without losing the air seal

Recessed Fixture in Insulated Ceiling

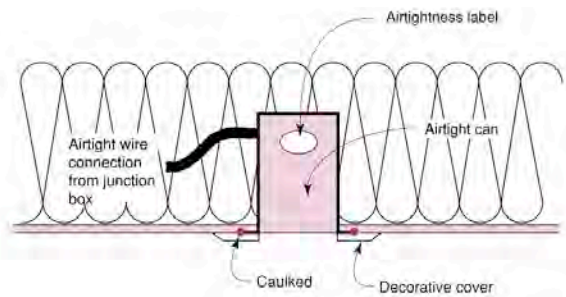

- Fixture labeled IC-rated and airtight as determined by ASTM E-283 air leakage test
- Housing (not decorative trim piece) sealed to ceiling with caulk or gasket

Suggestions for Further Research:

“Understanding Air Barriers”, Building Science Digest-104, www.buildingscience.com.

“READ THIS: Before You Design, Build, or Renovate,” Building Science Primer-040, www.buildingscience.com.

Lstiburek, Joseph W.; *Builder’s Guide Series*, Building Science Press, 2006.