

Measure Guideline: Three High Performance Mineral Fiber Insulation Board Retrofit Solutions

Building America Report - 1502

January 2015

Ken Neuhauser

Abstract:

This Measure Guideline describes a high performance enclosure retrofit package that uses mineral fiber insulating sheathing. The Measure Guideline describes retrofit assembly and details for wood frame roof and walls and for cast concrete foundations.

This Measure Guideline is intended to serve contractors and designers seeking guidance for non-foam exterior insulation retrofit and is best suited to contractors who are either familiar with exterior insulation and flashing installation or who can learn these techniques.

Exterior insulation retrofit is important to the goal of net zero energy ready homes. Mineral fiber insulating sheathing can provide enhanced moisture durability for the exterior enclosure. Mineral fiber also represents a viable solution for high performance home builders, designers, and clients who wish to use an alternative to foam plastic insulation.

Measure Guideline: Three High Performance Mineral Fiber Insulation Board Retrofit Solutions

K. Neuhauser
Building Science Corporation

January 2015

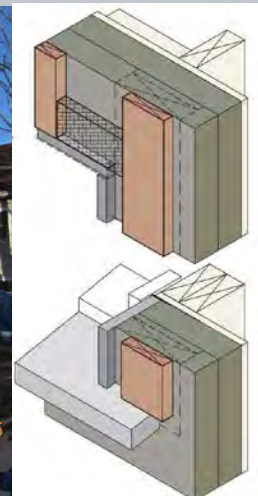
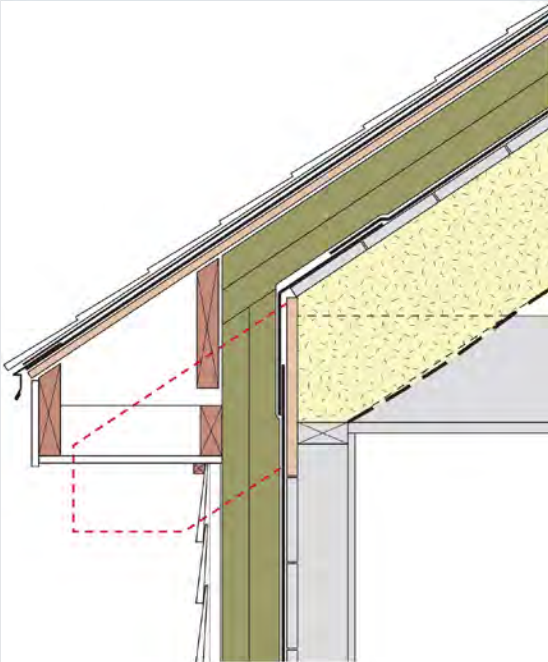

NOTICE

This report was prepared as an account of work sponsored by an agency of the United States government. Neither the United States government nor any agency thereof, nor any of their employees, subcontractors, or affiliated partners makes any warranty, express or implied, or assumes any legal liability or responsibility for the accuracy, completeness, or usefulness of any information, apparatus, product, or process disclosed, or represents that its use would not infringe privately owned rights. Reference herein to any specific commercial product, process, or service by trade name, trademark, manufacturer, or otherwise does not necessarily constitute or imply its endorsement, recommendation, or favoring by the United States government or any agency thereof. The views and opinions of authors expressed herein do not necessarily state or reflect those of the United States government or any agency thereof.

Available electronically at www.osti.gov/scitech

Available for a processing fee to U.S. Department of Energy and its contractors, in paper, from:

U.S. Department of Energy
Office of Scientific and Technical Information
P.O. Box 62
Oak Ridge, TN 37831-0062
phone: 865.576.8401
fax: 865.576.5728
email: <mailto:reports@adonis.osti.gov>

Available for sale to the public, in paper, from:

U.S. Department of Commerce
National Technical Information Service
5285 Port Royal Road
Springfield, VA 22161
phone: 800.553.6847
fax: 703.605.6900
email: orders@ntis.fedworld.gov
online ordering: www.ntis.gov/help/ordermethods.aspx



Printed on paper containing at least 50% wastepaper, including 20% postconsumer waste

**Measure Guideline:
Three High Performance Mineral Fiber Retrofit Solutions**

Prepared for:

The National Renewable Energy Laboratory

On behalf of the U.S. Department of Energy's Building America Program

Office of Energy Efficiency and Renewable Energy

15013 Denver West Parkway

Golden, CO 80401

NREL Contract No. DE-AC36-08GO28308

Prepared by:

Ken Neuhauser

Building Science Corporation

3 Lan Drive, Suite 102

Westford, MA 01886

NREL Technical Monitor: Stacey Rothgeb

Prepared under Subcontract No. KNDJ-0-40337-05

January 2015

The work presented in this report does not represent performance of any product relative to regulated minimum efficiency requirements.

The laboratory and/or field sites used for this work are not certified rating test facilities. The conditions and methods under which products were characterized for this work differ from standard rating conditions, as described.

Because the methods and conditions differ, the reported results are not comparable to rated product performance and should only be used to estimate performance under the measured conditions.

Contents

List of Figures	vii
List of Tables	ix
Definitions.....	x
Executive Summary	xi
Progression Summary: High Performance Mineral Fiber Roof Retrofit.....	xii
Progression Summary: High Performance Mineral Fiber Wall Retrofit	xiii
Progression Summary: High Performance Mineral Fiber Foundation Wall Retrofit.....	xiv
Introduction	1
1 Assess the Home.....	3
1.1 Risk Identification.....	3
1.1.1 Identify Site Risks.....	3
1.1.2 Identify Work Risks.....	5
1.2 Assess the Home To Determine Suitability of Options and the Need for Additional Control Measures	6
1.2.1 Roof Measure.....	6
1.2.2 Foundation Measure.....	6
2 Decision-Making Criteria	7
2.1 Cost and Performance	7
2.1.1 Roof Retrofit	7
2.1.2 Wall Retrofit	8
2.1.3 Translating the Cost of Foam Plastic Insulation Board to Mineral Fiber Insulation Board.....	9
2.2 Fire Code Issues.....	11
2.3 Moisture Performance.....	11
2.4 Cladding Attachment	13
2.5 Other Material Characteristics or Criteria.....	14
2.6 Trade Resources.....	14
3 Technical Description	15
3.1 High Performance Mineral Fiber Retrofit Assemblies	15
3.1.1 Mineral Fiber Retrofit Roof Assembly	15
3.1.2 Mineral Fiber Retrofit Wall Assembly	15
3.2 Material Properties and Criteria for Mineral Fiber Insulation Board	20
3.3 System Interaction	20
3.3.1 Water Control.....	20
3.3.2 Air Control	22
3.3.3 Vapor Control	23
3.3.4 Thermal Control.....	27
3.4 Climate Considerations.....	28
4 Measure Implementation	29
4.1 High Performance Mineral Fiber Retrofit Roof Assembly.....	29
4.1.1 Scope of Work	29
4.1.2 Climate-Specific Factors.....	29
4.1.3 Field Inspection.....	29
4.1.4 Implementation Risks	30
4.1.5 Installation Procedure	30

4.1.6	High Performance Mineral Fiber Retrofit Details	34
4.2	High Performance Mineral Fiber Retrofit Wall Assembly.....	41
4.2.1	Scope of Work	41
4.2.2	Climate-Specific Factors.....	42
4.2.3	Field Inspection.....	42
4.2.4	Implementation Risks	43
4.2.5	Installation Procedure	43
4.2.6	High Performance Mineral Fiber Retrofit Details	45
4.3	High Performance Mineral Fiber Retrofit Foundation Wall Assembly.....	94
4.3.1	Scope of Work	94
4.3.2	Climate-Specific Factors.....	94
4.3.3	Field Inspection.....	95
4.3.4	Implementation Risks	96
4.3.5	Installation Procedure	96
4.3.6	High Performance Mineral Fiber Retrofit Details	99
	References	102

List of Figures

Figure 1. Mineral fiber retrofit roof assembly.....	16
Figure 2. Mineral fiber retrofit roof assembly with a vented roof cladding.....	17
Figure 3. Mineral fiber retrofit wall assembly.....	18
Figure 4. Insulated ground roof included with mineral fiber retrofit foundation wall approach	19
Figure 5. Ratio of exterior to total insulation to control condensation of interior water vapor.....	26
Figure 6. Taped wood panel roof sheathing as air control membrane	31
Figure 7. “Chainsaw” transition of air and water control membrane.....	32
Figure 8. “Chainsaw” transition of air and water control membrane at rake	32
Figure 9. Pre-assembled insulated roof overhang framing being lifted into place at a gable rake for a “chainsaw” retrofit	33
Figure 10. Schematic detail for “chainsaw” eave transition from a high performance mineral fiber retrofit roof assembly to a high performance mineral fiber retrofit wall assembly	34
Figure 11. Schematic detail for non-“chainsaw” eave transition from a high performance mineral fiber retrofit roof assembly to a high performance mineral fiber retrofit wall assembly.....	35
Figure 12. Schematic detail for “chainsaw” gable rake transition from a high performance mineral fiber retrofit roof assembly to a high performance mineral fiber retrofit wall assembly	36
Figure 13. Schematic detail for “chainsaw” eave transition from a high performance mineral fiber retrofit roof assembly to a non-retrofit wall assembly	37
Figure 14. Schematic detail for non-“chainsaw” eave transition from a high performance mineral fiber retrofit roof assembly to a non-retrofit wall assembly.....	38
Figure 15. Schematic detail for “chainsaw” gable rake transition from a high performance mineral fiber retrofit roof assembly to a non-retrofit wall assembly.....	39
Figure 16. Schematic detail for transition from a lower high performance mineral fiber retrofit roof assembly to a high performance mineral fiber retrofit wall assembly	40
Figure 17. Schematic detail for transition from a lower high performance mineral fiber retrofit roof assembly to a non-retrofit wall assembly	41
Figure 18. Schematic detail for “chainsaw” eave transition from a high performance mineral fiber retrofit roof assembly to a high performance mineral fiber retrofit wall assembly	45
Figure 19. Schematic detail for non-“chainsaw” eave transition from a high performance mineral fiber retrofit roof assembly to a high performance mineral fiber retrofit wall assembly.....	46
Figure 20. Schematic detail for “chainsaw” gable rake transition from a high performance mineral fiber retrofit roof assembly to a high performance mineral fiber retrofit wall assembly	47
Figure 21. Schematic detail for eave transition from a high performance mineral fiber retrofit wall assembly to a non-retrofit roof assembly	48
Figure 22. Schematic detail for gable/rake transition from a high performance mineral fiber retrofit wall assembly to a non-retrofit roof assembly	49
Figure 23. Schematic detail for transition from a lower high performance mineral fiber retrofit roof assembly to a high performance mineral fiber retrofit wall assembly	50
Figure 24. Schematic detail for transition from a high performance mineral fiber retrofit wall assembly to an insulated lower roof assembly.....	51
Figure 25. Schematic detail for transition from a high performance mineral fiber retrofit wall assembly to an existing lower attic	52
Figure 26. Schematic detail for transition from a high performance mineral fiber retrofit wall assembly to a porch roof.....	53
Figure 27. Schematic detail for transition from a high performance mineral fiber retrofit wall assembly to an attached deck in a field of wall.....	54
Figure 28. Schematic detail for transition from a high performance mineral fiber retrofit wall assembly to an attached deck at base of wall.....	55
Figure 29. Schematic detail for transition from a high performance mineral fiber retrofit wall assembly to a top of high performance mineral fiber retrofit foundation wall assembly.....	56

Figure 30. Schematic detail for transition from a high performance mineral fiber retrofit wall assembly to a flat-surface foundation wall without exterior retrofit 57

Figure 31. Schematic detail for transition from a high performance mineral fiber retrofit wall assembly to a bumpy-surface foundation wall 58

Figure 32. Schematic detail for window head of new window or reinstalled window in a high performance mineral fiber retrofit wall assembly 59

Figure 33. Schematic detail for window jamb of new window or reinstalled window in a high performance mineral fiber retrofit wall assembly 60

Figure 34. Schematic detail for window sill of new window or reinstalled window in a high performance mineral fiber retrofit wall assembly 61

Figure 35. Steps 1 and 2 of installation sequence for new window or reinstalled window in a high performance mineral fiber retrofit wall assembly 62

Figure 36. Steps 3 and 4 of installation sequence for new window or reinstalled window in a high performance mineral fiber retrofit wall assembly 63

Figure 37. Steps 5 and 6 of installation sequence for new window or reinstalled window in a high performance mineral fiber retrofit wall assembly 64

Figure 38. Steps 7 and 8 of installation sequence for new window or reinstalled window in a high performance mineral fiber retrofit wall assembly 65

Figure 39. Steps 9 and 10 of installation sequence for new window or reinstalled window in a high performance mineral fiber retrofit wall assembly 66

Figure 40. Steps 1 and 2 of exterior trim installation sequence for window in a high performance mineral fiber retrofit wall assembly 67

Figure 41. Steps 3 and 4 of exterior trim installation sequence for window in a high performance mineral fiber retrofit wall assembly 68

Figure 42. Steps 5 and 6 of exterior trim installation sequence for window in a high performance mineral fiber retrofit wall assembly 69

Figure 43. Step 7 of exterior trim installation sequence for window in a high performance mineral fiber retrofit wall assembly 70

Figure 44. Schematic detail for window head of an existing window remaining in place in a high performance mineral fiber retrofit wall assembly 71

Figure 45. Schematic detail for window jamb of an existing window remaining in place in a high performance mineral fiber retrofit wall assembly 72

Figure 46. Schematic detail for window sill of an existing window remaining in place in a high performance mineral fiber retrofit wall assembly 73

Figure 47. Schematic detail for door head of new door or reinstalled door in a high performance mineral fiber retrofit wall assembly 74

Figure 48. Schematic detail for door jamb of new door or reinstalled door in a high performance mineral fiber retrofit wall assembly 75

Figure 49. Schematic detail for door sill of new door or reinstalled door in a high performance mineral fiber retrofit wall assembly 76

Figure 50. Steps 1 and 2 of installation sequence for new door or reinstalled door in a high performance mineral fiber retrofit wall assembly 77

Figure 51. Steps 3 and 4 of installation sequence for new door or reinstalled door in a high performance mineral fiber retrofit wall assembly 78

Figure 52. Steps 5 and 6 of installation sequence for new door or reinstalled door in a high performance mineral fiber retrofit wall assembly 79

Figure 53. Steps 7 and 8 of installation sequence for new door or reinstalled door in a high performance mineral fiber retrofit wall assembly 80

Figure 54. Steps 9 and 10 of installation sequence for new door or reinstalled door in a high performance mineral fiber retrofit wall assembly 81

Figure 55. Steps 11 and 12 of installation sequence for new door or reinstalled door in a high performance mineral fiber retrofit wall assembly 82

Figure 56. Steps 1 and 2 of exterior trim installation sequence for door in a high performance mineral fiber retrofit wall assembly 83

Figure 57. Steps 3 and 4 of exterior trim installation sequence for door in a high performance mineral fiber retrofit wall assembly 84

Figure 58. Steps 5 and 6 of exterior trim installation sequence for door in a high performance mineral fiber retrofit wall assembly 85

Figure 59. Step 7 of exterior trim installation sequence for door in a high performance mineral fiber retrofit wall assembly 86

Figure 60. Schematic plan (above) and section (below) details for wire penetration and fixture mount in a high performance mineral fiber retrofit wall assembly 87

Figure 61. Schematic plan and section details for wire penetration and exterior outlet box mount in a high performance mineral fiber retrofit wall assembly 88

Figure 62. Schematic plan and section details for duct penetration and vent hood trim mount in a high performance mineral fiber retrofit wall assembly 89

Figure 63. Steps 1 and 2 of sequence for treatment of duct/pipe penetration through a high performance mineral fiber retrofit wall assembly 90

Figure 64. Steps 3 and 4 of sequence for treatment of duct/pipe penetration through a high performance mineral fiber retrofit wall assembly 91

Figure 65. Steps 5 and 6 of sequence for treatment of duct/pipe penetration through a high performance mineral fiber retrofit wall assembly 92

Figure 66. Steps 7 and 8 of sequence for treatment of duct/pipe penetration through a high performance mineral fiber retrofit wall assembly 93

Figure 67. Step 9 of sequence for treatment of duct/pipe penetration through a high performance mineral fiber retrofit wall assembly 94

Figure 68. Schematic detail for insulated ground roof/foundation skirt with a high performance mineral fiber retrofit foundation wall assembly 99

A 69. Schematic detail for transition from a high performance mineral fiber retrofit wall assembly to a top of high performance mineral fiber retrofit foundation wall assembly showing how the metal closure/transition flashing is secured and sealed to the foundation wall. 100

Figure 70. Schematic detail for transition from a non-retrofit wall assembly to a top of high performance mineral fiber retrofit foundation wall assembly showing how the metal closure/transition flashing is secured and sealed to the foundation wall. 101

Unless otherwise noted, all figures were created by BSC.

List of Tables

Table 1. Recommended Minimum R-Value for High R-Value Enclosures..... 1

Table 2. NREMD Unit Costs for Insulation Board and Cavity Insulation Roof Retrofit (\$/ft²) 7

Table 3. National Residential Efficiency Measures Database Unit Costs for Insulation Board Wall Retrofit (\$/ft²)..... 8

Table 4. Estimates of Insulation Board Costs..... 9

Table 5. Board-Foot Material Costs for Various Insulation Board Materials From a Single Supplier and the Resulting Cost per Unit Area R-Value (\$/ft²-R) 9

Table 6. Weight per Unit Area R-10 Insulation for Various Insulation Board Materials (lb/ft²) 10

Table 7. Material Properties and Criteria for Mineral Fiber Insulation Board 20

Table 8. Ratio of Exterior Insulation to Total Assembly Insulation for Air Leakage Condensation Control at 68°F Indoor Temperature 24

Unless otherwise noted, all tables were created by BSC.

Definitions

bf	Board foot or board feet, used to refer to a volume of material 12 in. × 12 in. × 1 in. or 144 in. ³
DER	Deep Energy Retrofit
ft ²	Square Foot
IBC	International Building Code
IECC	International Energy Conservation Code
IRC	International Residential Code
NREMD	National Residential Efficiency Measures Database
OSB	Oriented Strand Board
PIC	Polyisocyanurate
SPF	Spray-Applied Polyurethane Foam
XPS	Extruded Polystyrene

Executive Summary

This Measure Guideline describes a high performance enclosure retrofit package that uses mineral fiber insulating sheathing. The Measure Guideline describes retrofit assembly and details for wood frame roof and walls and for cast concrete foundations.

This Measure Guideline is intended to serve contractors and designers seeking guidance for non-foam exterior insulation retrofit and is best suited to contractors who are either familiar with exterior insulation and flashing installation or who can learn these techniques.

Exterior insulation retrofit is important to the goal of net zero energy ready homes. Mineral fiber insulating sheathing can provide enhanced moisture durability for the exterior enclosure. Mineral fiber also represents a viable solution for high performance home builders, designers, and clients who wish to use an alternative to foam plastic insulation.

Progression Summary: High Performance Mineral Fiber Roof Retrofit

INSPECT AND ASSESS THE HOME

Inspect and Assess the Home: Identify and address risks to occupants or to the building that could be aggravated by the work. Verify safe working conditions. Determine whether the building has more urgent problems that must be addressed.

Do Not Proceed If:

- The house is not structurally sound.
- The house includes atmospherically vented combustion appliances (except cooking appliances).
- The house has knob-and-tube wiring in cavities that will be insulated.
- The house contains hazardous materials that pose a risk to occupants or workers.
- The house has active water leaks that will not be resolved by the retrofit projects.
- Kitchen and/or bath fans are not vented to the exterior.
- The home is not equipped with a whole-house ventilation system.
- The existing roof and/or insulation materials exhibit rot, insect damage, or contamination.



REMOVE CLADDING

1

Remove Roof Cladding. Remove roofing to expose the roof sheathing and prepare the roof sheathing for the air and water control membrane.

Optional Step: “Chainsaw” Retrofit. If roof framing allows, remove roof sheathing, rafter tails, and gable rake framing to be flush with the exterior wall sheathing. Provide infill as needed to allow wall sheathing plane to meet roof sheathing plane.

AIR AND WATER CONTROL MEMBRANE

2

Install Air and Water Control Membrane. Air and water control membrane must also provide the necessary vapor retarder performance. Install the air and water control membrane continuously across the roof sheathing surface and connect it in an airtight and durable manner with the air control layer of adjacent assemblies. Seal all penetrations against air and water leaks.

MINERAL FIBER INSULATION BOARD

3

Install Insulation Board. Install over the air and water control membrane. Butt joints tight. When installing multiple layers, offset seams in two directions.

Optional Step: “Chainsaw” Retrofit. Install framing for new roof overhangs over continuous insulation board.

Optional Step: Vented Roof. For vented roof, install 2 × 4 on the flat purlins over insulation board and fastened through insulation sheathing to roof structure.

ROOF SHEATHING

4

Install Roof Sheathing. Install roof sheathing to serve as a nailbase for roof cladding (e.g., shingles). Attach sheathing to roof structure through insulating sheathing. For a vented roof, attach roof sheathing to purlins.

ROOF CLADDING AND FLASHING

5

Install Underlayment, Flashing, and Roofing. Install underlayment, ice and water membrane, flashings, and roofing as per new construction best practices.

Progression Summary: High Performance Mineral Fiber Wall Retrofit

INSPECT AND ASSESS THE HOME

Inspect and Assess the Home: Identify and address risks to occupants or to the building that could be aggravated by the work. Verify safe working conditions. Determine whether the building has more urgent problems that must be addressed.

Do Not Proceed If:



- The house is not structurally sound.
- The house includes atmospherically vented combustion appliances (except cooking appliances).
- The house has knob-and-tube wiring or other electrical hazards.
- The house contains hazardous materials that pose a risk to occupants or workers.
- The house has active water leaks that will not be resolved by the retrofit project.
- Kitchen and/or bath fans are not vented to the exterior.
- The home is not equipped with a whole-house ventilation system.
- The existing roof and/or insulation materials exhibit rot or insect damage or contamination.

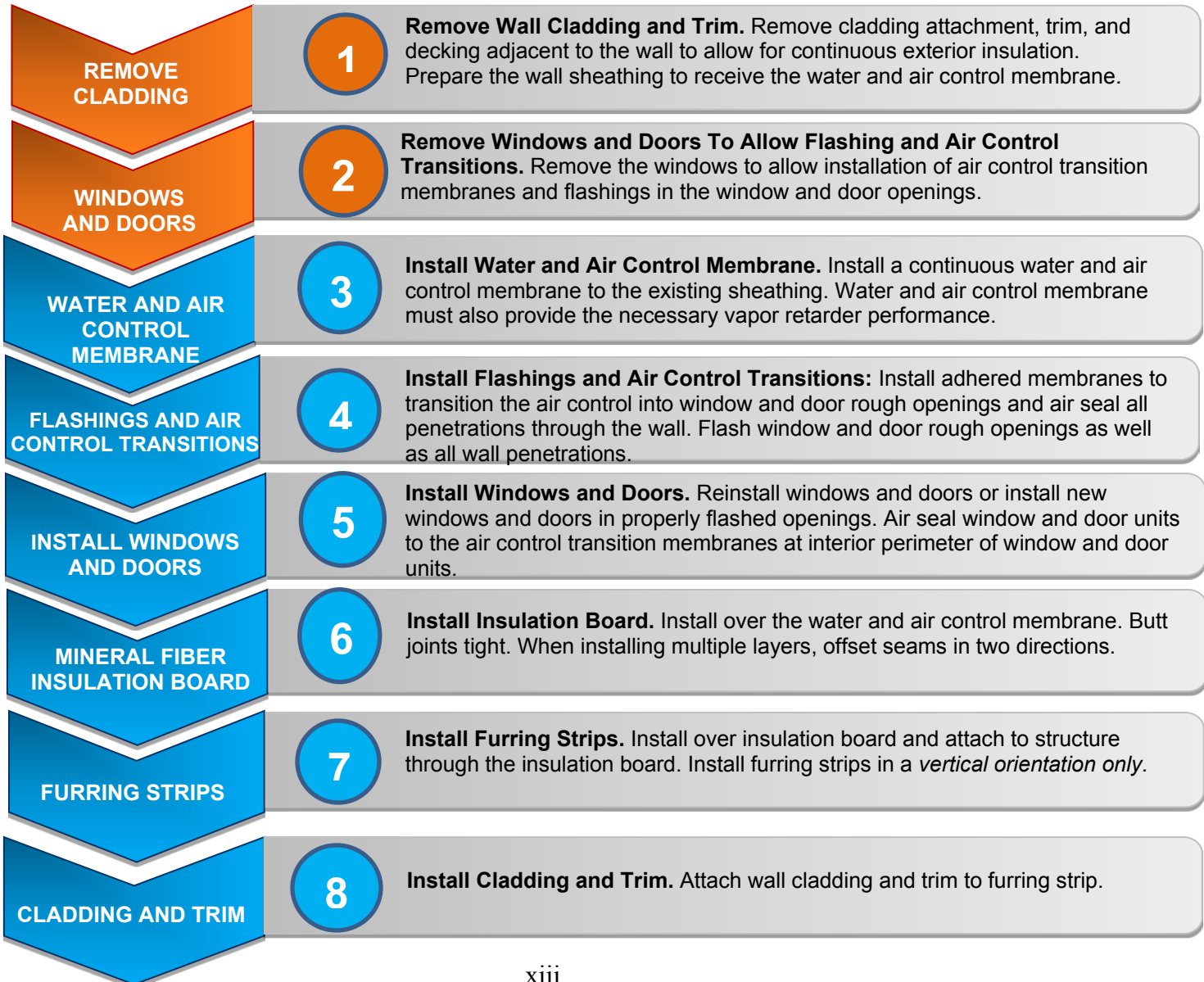

Progression Summary: High Performance Mineral Fiber Foundation Wall Retrofit

INSPECT AND ASSESS THE HOME

Inspect and Assess the Home: Identify and address risks to occupants or to the building that could be aggravated by the work. Verify safe working conditions. Determine whether the building has more urgent problems that must be addressed.

Do Not Proceed If:



- The house is not structurally sound.
- Framing exhibits rot or insect damage.
- Underground electric and gas service to the building or passing near the foundation has not been located.
- Soil around the foundation is contaminated (e.g., with lead, pesticides).
- The house includes atmospherically vented combustion appliances (except cooking appliances).
- The house has knob-and-tube wiring or other electrical hazards.
- The house contains hazardous materials that pose a risk to occupants or workers.
- The house has active water leaks that will not be resolved by the retrofit project.
- Kitchen and/or bath fans are not vented to the exterior.
- The home is not equipped with a whole-house ventilation system.

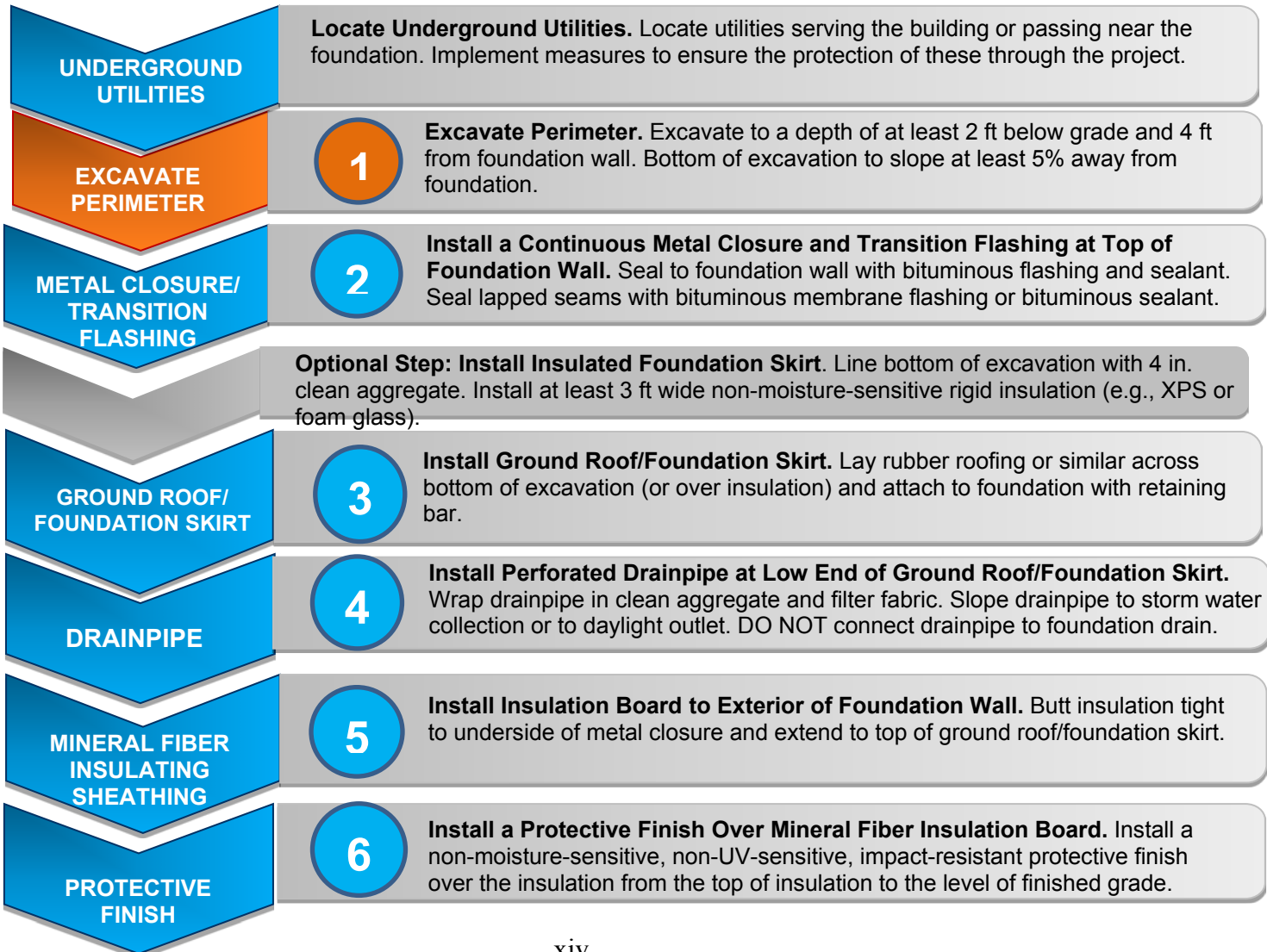

Introduction

This Measure Guideline provides details and procedures for high performance retrofit using insulation board composed of mineral fiber material. Specifically, the guide demonstrates techniques for retrofitting three major enclosure components: roofs, walls, and foundation walls. The strategies and procedures developed in this guide are directed to wood-framed residential buildings with sloped roofs and cast concrete, block, or brick masonry foundation walls. The approach supported in this guide could also be adapted for use over masonry-clad or bearing masonry structures.

Table 1 shows the minimum assembly R-value that would constitute a high R-value enclosure for the various International Building Code (IBC)/International Energy Conservation Code (IECC) climate zones and pertinent enclosure components. These values are based on work by Straube (2010). A high performance retrofit, sometimes referred to as a deep energy retrofit (DER), results in enclosure components that meet these high R-value targets.

Table 1. Recommended Minimum R-Value for High R-Value Enclosures

Climate Zone	Building Enclosure Component			
	Wall	Compact Roof	Basement Wall	Slab Edge
1	10	35	5	None
2	15	40	10	5
3	20	45	10	7.5
4	25	45	15	7.5
5	30	50	15	10
6	35	60	20	10
7	40	65	25	15
8	50	75	35	20

DER has been shown to provide a path to net zero energy ready homes for existing homes (Gates and Neuhauser 2013, 2014). High performance enclosure retrofit can position an existing building to perform at the level of best-in-class new construction. Retrofitting a wood-framed enclosure with thick layers of foam plastic insulation board is a proven high performance retrofit technique.

An exterior retrofit is generally more favorable than an interior retrofit because it is less disruptive to the living space and typically allows a structure to remain occupied during the project. Exterior retrofit also offers significant advantages for building durability by reducing the likelihood of cold weather condensation within the structure.

However, Ueno (2010) observed that although thick insulation board virtually eliminates the risk of condensation from outward vapor drive (cold weather condensation), vapor-impermeable insulation board can make a wall more vulnerable to water leaks than walls without insulation board. Homes built more recently often incorporate engineered wood sheathing (oriented strand board, OSB) and rim boards. When these elements are insulated to the interior with closed-cell spray-applied polyurethane foam (SPF) insulation, drying to the exterior becomes critical and

foam plastic insulation board applied directly over the wall could present a problem (Lstiburek 2013b). Mineral fiber provides a vapor open insulation board that is key to making these assemblies both high R-value and moisture safe.

This Measure Guideline is important to the high performance retrofit industry because it demonstrates techniques for using vapor-open, noncombustible, mineral fiber insulation board in a high performance enclosure retrofit.

This Measure Guideline includes a review of decision criteria pertinent to the selection of a mineral fiber-based retrofit strategy. These criteria include relative cost, combustibility, moisture performance, cladding attachment, trade resources, as well as other considerations associated with the insulation material.

Risks that must be addressed with a high performance enclosure retrofit generally, and with a mineral fiber-based enclosure retrofit specifically, are outlined. Proper techniques for moisture management as well as climate-specific considerations are reviewed. Cladding attachment considerations are also discussed.

Although the Measure Guideline does not include any recognized fire resistance rated details or assemblies, it does present methods to improve the fire resistance of the retrofit assembly.

This Measure Guideline is intended to support contractors implementing a mineral fiber-based high performance enclosure retrofit as well as designers looking to design a high performance enclosure retrofit using an alternative to foam plastic insulation. The Measure Guideline may also be helpful to building owners wishing to learn more about strategies available for high performance retrofit of wood-framed residential buildings.

1 Assess the Home

1.1 Risk Identification

1.1.1 Identify Site Risks

Before a significant retrofit project is conducted, the home must be assessed to determine whether significant, if hidden, problems should be addressed as higher priorities than an enclosure performance upgrade. Also, changes to the building enclosure will have a significant impact on the dynamics of water, air, vapor, and heat flow within the home. Certain measures should be implemented prior to, or as part of, any significant enclosure retrofit project to ensure that these changing dynamics do not have negative ramifications for health and safety or for building durability. Measures to be implemented prior to or as part of the enclosure retrofit outlined in this Guide relate to:

- Remediation of existing hazardous conditions
- Combustion safety
- Indoor air quality.

The measures described to address indoor air quality include mechanical ventilation and soil gas control. These are not the only means to ensure good indoor air quality. However, effective mechanical ventilation and soil gas control are essential aspects of the building (as contrasted to furnishings, equipment, materials, etc. that people might bring into a building) that provide the occupants a means to control contaminants and respond to indoor air conditions.

1. Remediate hazardous conditions.

Before a DER project begins, any hazardous conditions must be remediated that will be affected (e.g., exposed or aggravated) by the planned work. Also, it is wise to ensure that more serious problems are not lurking. A high performance enclosure retrofit—however worthy the goals may be—should not divert resources from where they are more urgently needed.

Before embarking on a project as outlined in this Guide, inspect and assess the building for:

- Structural integrity of the frame and foundation
- Safety and serviceability of the electrical system
- Hazardous materials (e.g., lead, radon, asbestos)
- Rainwater, groundwater, or plumbing water leaks
- Rot or decay in framing
- Insect and other pest damage and activity.

The structural system must be sound before high performance retrofit work can begin. Similarly, the electrical system must provide basic electrical safety. Knob-and-tube wiring may preclude retrofit of the enclosure; a licensed electrician should be consulted to discuss the nature of the retrofit and determine whether knob-and-tube wiring should be replaced. Ideally, the electrical

system would be brought up to date with current code and brought into alignment with current and projected building needs.

Hazardous materials that will be affected by the planned work or that may impact the indoor air quality must be remediated and/or removed to avoid exposure to occupants or workers.

Any bulk water issues, whether these relate to rainwater leaks, groundwater infiltration, or plumbing system leaks, must be repaired before the enclosure retrofit project proceeds, unless the planned work will remove the source of the bulk water issue (e.g., if the roof surface or leaking section of plumbing is to be replaced as part of the project).

Any framing that shows signs of rot or decay should be replaced. This frequently applies to the framing sill in older buildings. Also, any framing that exhibits preconditions for rot or decay—i.e., damp wood—will require remediation.

Past insect and pest damage must be evaluated for impact on the building. Ongoing insect and pest activity must be remediated.

Follow applicable laws and industry procedures for mitigation of hazardous materials. Engage the services of a qualified professional when needed.

2. Ensure combustion safety.

Atmospherically vented (or naturally aspirated) combustion appliances are not appropriate for high performance homes. With the exception of gas cooktops, ranges, and wall ovens, combustion appliances should be direct-vented or direct exhaust-vented equipment. These types of appliances are significantly more energy efficient than natural draft appliances. If replacing equipment is not feasible, draft inducer retrofit kits can provide fail-safe forced-draft performance for some types of combustion appliances. This can address the combustion safety issue; however, adding forced-draft operation alone is unlikely to have a significant impact on energy performance.

Gas cooktops, ranges, and wall ovens must be equipped with a range hood that is ducted to the outside.

Solid fuel-burning stoves (e.g., wood stoves and pellet stoves) if not equipped with a fail-safe draft inducer, must have a tight-fitting loading door (and no permanent openings or leaks into the firebox or flue) and outdoor combustion air ducted to the firebox. If any combustion appliance vents through a chimney, the flue should be inspected to ensure that it is in good condition. The flue must be repaired if it exhibits any deficiencies.

Attached garages present a potential source of carbon monoxide and other contaminants that could infiltrate into the home. Consult the Indoor airPlus guides for specific guidance on treatment of attached garages.

If the house has combustion appliances of any kind or an attached garage, carbon monoxide alarms complying with Underwriters Laboratories 2034 should be placed in reasonable

proximity to the combustion appliances, in any regularly occupied space adjoining an attached garage, and outside each separate sleeping area in the immediate vicinity of the bedrooms.

3. Ensure adequate ventilation

Mechanical ventilation is an essential feature of high performance homes. Ventilation is needed for source control at the location of contaminant sources (e.g., kitchens, bathrooms, craft areas) as well as for distribution of fresh air and dilution of general contaminants. The distribution of fresh air and dilution of general contaminant is referred to as *background* or *whole-house* ventilation.

The 2012 International Residential Code (2012 IRC) provides code minimum requirements for ventilation systems, including the ventilation rate capacity for background/whole-house ventilation and source control ventilation. This Guide aims to provide additional guidance toward meeting the high performance objectives of DER projects.

4. Control soil gas.

Before any enclosure retrofit project begins, measures must be taken to prevent entry of soil gases into the home. Radon is a soil gas with significant and well-documented health risks. Air moving through soil also carries significant moisture and may carry other contaminants such as mold spores, herbicides, pesticides, and methane.

As a minimum soil gas control measure, cracks and holes in the foundation walls and basement slab must be sealed. Because of the need for soil gas control, it is important that any penetrations made through ground-contact assemblies (slabs and foundation walls) are sealed. Sump pits must have airtight and gasketed covers.

Implementation of a soil gas venting system is strongly recommended. Any significant work to the roof or basement/crawlspace provides an opportunity to establish such a system.

A soil gas venting system essentially provides the soil gas a direct pathway from below the house to the outdoors so that it does not move through the indoor living space. If needed, a fan can be added to the vent pipe to actively move soil gases from beneath the basement floor to the outside.

For additional information on soil gas control, see [Radon Fan](#) and [Vertical Radon Ventilation Pipe](#) on the Building America Solution Center website.

1.1.2 Identify Work Risks

In addition to the hazardous material risks indicated above, other risks to worker and building safety must be addressed before work commences.

1. Locate gas and electric utilities.

The foundation retrofit measures described in this guide require excavation adjacent to the foundation. Before foundation retrofit work begins, any underground gas or electric utilities in the vicinity of the excavation must be located.

Overhead wires could present a safety hazard for wall and roof retrofit measures. Work and staging in the vicinity of overhead wires must be carefully planned to provide safe working conditions.

2. Assess staging needs.

The wall and roof retrofit measures described in this guide require ladders, staging, or mechanical lifts. Carefully review the area around the building to assess the suitability of the ground to support ladders, staging, or mechanical lifts.

1.2 Assess the Home To Determine Suitability of Options and the Need for Additional Control Measures

1.2.1 Roof Measure

Investigate the roof assembly to determine whether it has vapor retarders, and if so, what type. Examples of vapor retarders of concern could be class I and class II types such as OSB sheathing, closed-cell SPF insulation to the underside of the roof sheathing, kraft or foil facings on fibrous insulation, a polyethylene vapor retarder, and plaster finish with oil-based paint.

Assess the roof and wall structural systems to determine whether they can support a “chainsaw” approach. If the roof overhang framing is part the roof truss or if roof rafters are supported beyond the top of the wall on cantilevered framing, a “chainsaw” approach is not recommended.

1.2.2 Foundation Measure

The exterior foundation retrofit described in this Guide requires that the foundation wall surface be relatively flat. If the foundation wall is constructed of field stone or fractured block, other retrofit strategies should be pursued.

The exterior foundation retrofit described in this Guide also requires excavation around the perimeter of the building. Assess whether there are impediments to excavation. Excavation necessitates locating underground utilities in the vicinity of the planned excavation.

It will also be important to assess how surface water and roof runoff can be drained. Does the site allow a drain to daylight? Will a storm water collection or drywell be required?

2 Decision-Making Criteria

2.1 Cost and Performance

Cost and performance are intricately linked and have to be studied in conjunction to determine the best choice per the decision-maker’s goals and objectives. Installation costs for the retrofit solutions described in this Measure Guideline can be expected to vary widely from estimates in the referred sources to field experience depending on such factors as contractor experience, prevalent region practices, material costs, and the particular circumstances of the project. It is worth noting that the range is sometimes a factor of 5 to 10.

2.1.1 Roof Retrofit

As with the walls, the National Residential Efficiency Measures Database (NREMD) does not directly provide a cost estimate for retrofitting insulating board to wood-framed roof assemblies. The retrofit measures provided that are relevant to a conditioned attic include both cavity insulation and insulation board. For a retrofit situation, it may reasonably be the mode that pre-retrofit case involves an insulated attic space; therefore, insulating within rafter cavities would be a necessary part of the measure. The NREMD does not provide costs for removal of roofing but does provide cost estimates for replacing an asphalt roof with a unit cost range of \$1.90/ft² to \$4.30/ft² (see Table 2).

Table 2. NREMD Unit Costs for Insulation Board and Cavity Insulation Roof Retrofit (\$/ft²)

Retrofit Description (Cavity Insulation, Insulation Board)	Nominal R-Value	Cost Range (\$/ft ²)
R-19 Fiberglass, 3 in. XPS*	34	2.10–3.60
R-19 Fiberglass, 4 in. XPS	39	2.50–4.20
R-30 Fiberglass, 3 in. XPS	45	2.40–4.10
R-30 Fiberglass, 4 in. XPS	50	2.80–4.70
R-38 Fiberglass, 3 in. XPS	53	2.60–4.50
R-38 Fiberglass, 4 in. XPS	58	3.00–5.10
R-38 Fiberglass, 5 in. XPS	63	3.40–5.80

* Extruded polystyrene

The National Grid DER pilot projects that Gates and Neuhauser (2014) evaluated pursued a roof/attic insulation target of R-60. The projects that met this target with a strategy including both insulation board and framing cavity insulation, all used either 4 in. or 6 in. of polyisocyanurate (PIC) insulation board. The reported unit costs for this strategy (excluding outliers) ranged from \$10.05/ft² to \$21.84/ft².

The target thermal performance in the National Grid DER pilot might correspond to the nominal values of the NREMD for R-38 fiberglass plus 4–5 in. of XPS insulating sheathing; however, the costs reported for the National Grid DER pilot projects would reflect elements beyond the insulation. For example, the reported pilot project costs would include removal of existing roofing, installation of an air and water control membrane over the existing sheathing,

installation of a second layer of roof sheathing above the insulation board, and, in many cases removal and subsequent reconstruction of roof overhangs. Actual costs for the roof retrofit solution described in this guide are expected to be generally higher and more variable than the estimates derived from NREMD.

2.1.2 Wall Retrofit

The NREMD does not directly provide a cost estimate for retrofitting an existing wood-framed wall with insulation board; however, a composite of measures can be used to develop an estimate from this source. The NREMD provides a range and an average cost for various exterior insulation measures. The database also provides a figure for the cost of removing wall cladding (\$0.66 regardless of cladding type), and estimated cost ranges for installation of new cladding.

Table 3 represents these cost data.

**Table 3. National Residential Efficiency Measures Database
Unit Costs for Insulation Board Wall Retrofit (\$/ft²)**

Insulation Thickness and Material	NREMD Insulation Board Measure Cost	Cost With Removal of Wall Cladding and Installation of Vinyl Siding	Cost With Removal of Wall Cladding and Installation of Wood Siding	Cost With Removal of Wall Cladding and Installation of Fiber-Cement Siding
1 in. XPS	0.93–1.60	4.19–5.06	4.89–6.26	4.69–5.96
1 in. PIC	0.86–1.40	4.12–4.86	4.82–6.06	4.62–5.76
2 in. XPS	1.30–2.20	4.56–5.66	5.26–6.86	5.06–6.56
2 in. PIC	1.10–1.90	4.36–5.36	5.06–6.56	4.86–6.26
3 in. XPS	1.60–2.80	4.86–6.26	5.56–7.46	5.36–7.16

Interestingly, the NREMD data do not show a significant cost jump from 1 in. thick insulation board to 2 in. of insulation board. Such a cost jump would be expected because with an insulation board thicker than 1 ½ in., furring strips would be required for cladding attachment. Baker (2012) used data from RS Means to derive estimates of installed cost of insulation board (not including cladding) (Table 4). Baker estimated the cost of installing 1.5 in. PIC insulation board at \$1.56/ft², whereas the estimate for 2 in. PIC insulation board is \$3.53, a difference of \$1.97. Given the modest \$0.19 cost difference that Baker estimated between 1 in. and 1 ½ in. insulation board, it is reasonable to assume that most of the cost difference he projects between 1 ½ in. and 2 in. insulation board is due to the installation of 1 × 4 wood furring strips. Given this, Baker’s estimates for the installed cost of insulation board at these thicknesses can be taken to be otherwise consistent with NREMD. For insulation board thicker than 2 in., Baker projects installation in two layers (recommended practice), which results in another price jump between 2 in. and 3 in. thickness of insulation board.

Table 4. Estimates of Insulation Board Costs

Baker (2012)

Insulation Board	Estimated Insulation Board Installed Cost (\$/ft ²)	Cost Increment (\$/ft ² Difference Relative to Previous)
1 in. PIC	1.35	–
1 ½ in. PIC	1.56	0.21
2 in. PIC With 1 × 4 Wood Furring	3.53	1.97
3 in. PIC in 2 Layers With 1 × 4 Wood Furring	4.99	1.46
4 in. PIC in 2 layers With 1 × 4 Wood Furring	5.38	0.39

Gates and Neuhauser (2014) reported on the experience of 42 DER projects that participated in a National Grid-sponsored pilot program. For 36 projects that implemented a wall retrofit including 4 in. of insulation board (in two layers, with wood furring strips), the reported energy-related (e.g. excluding siding and trim) unit cost (excluding outliers) ranged from \$4.67/ft² to \$19.15/ft². Estimates derived from NREMD or from RS Means are within the range reported by Gates and Neuhauser; however, the data from the National Grid DER pilot provides evidence that the range for costs in actual projects is likely to be large.

2.1.3 Translating the Cost of Foam Plastic Insulation Board to Mineral Fiber Insulation Board

The above measure cost estimates all use data for foam plastic insulation board. Cost data for residential mineral fiber insulation board are not widely available in the United States. Wilson (2013) used data from a single building supply house for a benchmark comparison. Wilson reported these cost in terms of board feet (bf) of material. Given the R-value/inch of the material, the bf cost can be used to derive a cost/ft²-R-value (Table 5). This is a very useful metric for comparing materials and for deriving a unit material cost estimate for meeting a given R-value assembly target.

Table 5. Board-Foot Material Costs for Various Insulation Board Materials From a Single Supplier and the Resulting Cost per Unit Area R-Value (\$/ft²-R)

Insulation Board Material	Board Foot Cost (\$/bf)	R-Value per Inch	Cost per Unit Area R-Value Cost (\$/ft ² -R)
Comfort Board Insulated Sheathing	0.64	4	0.160
PIC	0.48	6.5	0.074
Foil-Faced, Fire Exposure-Rated PIC	0.75	6.5	0.115
XPS	1.07	5	0.214

According to data from this one source, the material cost relative to thermal resistance for XPS is roughly 2–3 times that for an equivalent amount of thermal resistance provided by PIC. The material cost relative to thermal resistance for mineral fiber insulation board appears to be somewhere between that of XPS and PIC. Therefore, one might expect that the cost for insulation board retrofits using mineral fiber would be comparable to otherwise similar solutions that use foam plastic insulation board.

It is worth noting that the NREMD data do not show the same cost difference between XPS and PIC as the data from one building supply outlet that Wilson reported. Material costs are thus likely to vary considerably between markets.

In addition to material cost difference, other factors would influence cost difference between mineral fiber retrofit solutions and otherwise similar retrofit approaches that employ foam plastic insulation board. The fibers from mineral fiber insulation can cause skin irritation. This may be a considerable challenge to installation of mineral fiber insulation board in warmer weather, when maintaining full skin coverage may cause workers to be uncomfortable. The author observed that mineral fiber may also increase the risk of eye injury on the job site. In one construction project in which the author participated, construction was delayed on multiple occasions when a worker was taken for urgent medical treatment when he apparently rubbed his eye after handling mineral fiber material.

Because mineral fiber has lower thermal resistance per unit thickness than either PIC or XPS, mineral fiber assemblies will require greater thickness to achieve the same nominal R-value. Therefore, a mineral fiber insulation board retrofit may require longer screws and more material for trim returns than an otherwise similar retrofit strategy using either PIC or XPS.

Also important to installation cost is the weight of the insulation board. As shown in Table 6, mineral fiber insulation board is more than 6 times heavier than either PIC or XPS for a given R-value and area. This will affect the effort needed to move material into place and brace it while fastening. The relative weight of mineral fiber insulation board as well as general strength characteristics of the material typically require use of smaller pieces of material. This would impact the time and effort required to cover a given area of wall or roof with insulation board.

Table 6. Weight per Unit Area R-10 Insulation for Various Insulation Board Materials (lb/ft²)

Insulation Board Material	Board Foot Cos (\$/bf)	R-Value per Inch	Weight per Unit Area at R-10 (lb/ft²)
Comfort Board Insulated Sheathing	8	4	1.67
PIC	2	6.5	0.26
XPS	1.3–1.55	5	0.18-0.26

To estimate the magnitude of these various factors beyond material cost would be mere speculation. In time, experience of contractors will yield approximate installation costs for mineral fiber insulation board retrofit solutions.

2.2 Fire Code Issues

Before deciding to use mineral fiber insulation board in the retrofit, it is important to determine whether its fire resistance property is a code issue. Mineral fiber is a noncombustible material that, at adequate thickness, is recognized in codes as providing a thermal barrier. Mineral fiber insulation achieves its fire resistance without the use of chemical flame retardants such as those used in foam plastic insulation materials.

Exterior retrofit systems using mineral fiber insulation board can be constructed such that they offer enhanced fire protection. However, as noted by Lstiburek (2013a), mineral fiber insulation board assemblies have not been “officially burned” to earn recognition as fire-resistance rated assemblies. Design of systems to meet fire-resistance rating requirements is beyond the scope of this guide.

2.3 Moisture Performance

The decision about the robustness of a moisture control assembly depends on the decision-maker’s willingness to pay. Design of retrofit assemblies must consider management of bulk water loads, interior water vapor loads, and exterior water vapor loads. For roofs and walls, the principal bulk water load is generally related to rain and (in some climates) melting snow. Capillary transfer of water will impact foundation assemblies and may impact the base of a frame wall that is not separated from the foundation by a capillary break. Surface water, roof runoff, and groundwater are typical bulk water loads that must be managed by the foundation. Irrigation may also contribute a bulk water load that impacts foundation walls and above-grade walls.

Interior water vapor loads apply to assemblies of occupied structures that use heating systems and/or that have significant interior moisture generation (e.g., swimming pool, greenhouse, extensive cooking).

Exterior water vapor loads apply to assemblies of occupied structures that include mechanical air conditioning. Exterior water vapor loads are also pertinent to structures that have reservoir claddings (e.g., brick veneer, stucco, wood, fiber cement) that are exposed to wetting (from rain or irrigation) and sunlight.

Fire Separation Distance

The International Residential Code for One and Two Family Dwellings (IRC) requires that assemblies have a 1-hour fire-resistance rating if the minimum fire separation distance between structures is 5 ft or shorter. Under the IBC, the requirement for fire-resistance rating applies with the minimum fire separation distance is 10 ft or shorter. Very few listed assemblies contain insulation board that carries the required fire-resistance rating. The IBC provides a potential avenue for the use of mineral fiber insulation board that relies upon interpretation by the building official. Section 703.2 reads:

Where material, systems, or devices that have not been tested as part of the fire-resistance-rated assembly are incorporated into the building element, component or assembly, sufficient data shall be made available to the building official to show that the required rating is not reduced.

Exterior insulation board brings the primary sheathing closer to interior conditions and thus reduces the condensation potential at the primary sheathing relative to outward (heating season) vapor drive. LePage and Lstiburek (2012) found that exterior insulation greater than R-5 is a better outward vapor control strategy than interior vapor retarders. Smegal and Straube (2011) evaluated thicker vapor-permeable and vapor-impermeable insulation board relative to management of interior water vapor loads. Their analysis suggests that with thick insulation board the vapor permeability of insulation board is not a significant factor in managing interior vapor loads.

LePage et al. (2013) found through hygrothermal modeling that a high R-value wall with 4 in. of exterior insulation provided sufficient condensation resistance in cold climates but that a significant rain water leak (5% of wind-driven rain) to the insulation board-sheathing interface would most certainly result in damage.

Ueno (2010) noted some moisture management advantages in the exterior insulation board approach to superinsulation:

For the most part, the retrofit assembly tends to improve durability of the wall, due to the drained and ventilated cavity, the redundant drainage planes (multiple layers of foam, housewrap), and the reduction in interstitial condensation risk by elevating the condensing surface temperature with exterior insulation.

Ueno notes, however, that the loss of drying to the exterior could have durability implications. He found that a leak (in terms of percentage incident rain penetration) that is “survivable” (in terms of maintaining sheathing moisture content below a critical threshold) in pre-retrofit conditions is not survivable when the building is retrofitted with vapor-impermeable insulation board. Based on this analysis, Ueno indicated, it is critical to ensure proper flashing when implementing an exterior superinsulation retrofit. BSC guidance and review of superinsulation retrofit using exterior insulation board has strongly emphasized robust water management (Baker 2012; BSC 2010; Neuhauser 2011; Pettit 2009; Pettit et al. 2013).

Smegal and Straube (2011) compared the performance of wood-framed walls with either XPS or mineral fiber insulation board. At greater R-value of insulating the mineral fiber showed little advantage in managing outward vapor drive compared to the XPS. A difference in simulated performance was more noticeable with thinner (lower R-value) insulation board. The hygrothermal analysis also showed some appreciable difference in the drying potential for the mineral fiber assemblies in simulated winter and summer conditions. For OSB or engineered wood products, rapid drying from moisture concentrations would be more critical. Plywood or sawn wood sheathing offers some benefit of hygric redistribution within the material (Lstiburek 2010).

Lstiburek (2013a) observed that OSB sheathing with low permeability materials to interior and low permeable or impermeable insulation board require an air gap between sheathing and insulation board for drying and hygric redistribution. Lstiburek also notes that vapor open insulation board can provide useful drying without this added air gap.

Inward vapor drive is a risk factor associated with warm-humid climates, air conditioning, and reservoir claddings. Dérome et al. (2010) observed that warm-humid and mixed-humid climates

pose a risk to vapor-permeable wall assemblies. They further observed that rain-wetted reservoir claddings exposed to strong solar radiation (sunlight) can produce a very strong inward vapor drive.

Through hygrothermal simulation, Lepage and Lstiburek (2012) found that a vapor control membrane with a vapor permeance of up to 10 perms is sufficient to protect OSB sheathing from sustained elevated moisture content, provided that no significant vapor retarders are placed to the interior of the sheathing (e.g., polyethylene or vinyl wall covering). This study evaluated vapor control membranes with a permeance of 0.1, 1, 10, and 50 and located an inflection point in wall behavior with a vapor control of 10 perms. This analysis showed that vapor control at the exterior of sheathing (between vapor permeable insulation board and structural sheathing) is more important to protecting the wall where drying to the interior is impeded by a significant vapor retarder such as may be represented by vinyl wall covering, polyethylene, or foil facing.

2.4 Cladding Attachment

Rigid foam insulation board has long been established as a suitable substrate behind furring strips used for cladding attachment. The compressive resistance of mineral fiber insulation board is appreciably less than the compressive resistance of rigid foam typically used for insulation board.

As summarized by Holladay (2011), laboratory testing has demonstrated that a wall configuration using 8/ft³ mineral fiber insulation and furring strips for cladding attachments can support common cladding systems with negligible initial as well as long-term deflection. However, long-term testing in exposed conditions, with significant diurnal and seasonal temperature variations (unlike in a lab) shows considerably more movement of furring strips attached over insulation board and with imposed cladding loads. Ongoing research by BSC and Building Science Labs has shown that mineral fiber insulation board performs very similarly to PIC and XPS relative to movement of furring strips under loads representative of lightweight (e.g., vinyl, wood siding) to medium weight (e.g., stucco) cladding. This research has yielded the conclusion that cladding weight should be limited to 10 lb/fastener over insulation board (including mineral fiber insulation board) at thicknesses up to 4 in. Further research is needed to confirm the capacity of furring strip cladding attachment with thicker insulation board.

Critical Takeaway

Space screw fasteners in furring strips such that the cladding load amounts to no more than 10 lb per fastener at thicknesses up to 4 in.

A challenge noted for installation of furring strips over a “softer” insulation board such as mineral fiber insulation board, is maintaining plumb and planar furring strips (Cowan and Walsh 2013). The initial force of setting the fastener through the furring strip can easily compress the mineral fiber insulation board. Contractors have developed various methods to assist in maintaining plumb and planar furring.

2.5 Other Material Characteristics or Criteria

Styrene foam plastic building insulation is manufactured with brominated flame retardants. These are widely recognized as persistent organic pollutants (Wilson 2013). Other foam plastic building insulation materials also incorporate chemical flame retardants. As noted above, mineral fiber insulation does not use added chemical flame retardants.

Mineral fiber insulation products currently available do, however, use formaldehyde-based binders. As such, certain building labeling and recognition programs, such as the Living Building Challenge, preclude the use of mineral fiber building insulation. Wilson (2013) relayed manufacturers' explanations that the high temperature production process drives off nearly all of the free formaldehyde. Wilson also alluded to test data showing formaldehyde emissions from mineral fiber insulation to be below or near background levels.

2.6 Trade Resources

Despite recent gains and the development of manufacturing capacity in the United States, the distribution network for mineral fiber insulation board is still nascent. Mineral fiber batt insulation is—and has been—widely available; however, mineral fiber insulation board sheathing is not stocked in “big box” consumer-oriented building supply retailers.

Experience with insulation board installation is still far from universal in the residential building sector. Immediate adoption of mineral fiber insulation board retrofit solutions is probably best suited to contractors who have been trained in these techniques, because they require exacting attention to details.

Strategies To Achieve Plumb and Planar Furring Strips

A persistent challenge with installing furring strips over mineral fiber insulating is maintaining plumb and planar furring strips. Setting and adjusting fasteners to plumb furring strips and plane out a wall can be time consuming. Strategies that contractors have developed to make this step easier include:

- Hand setting cap nails to act as spacers prior to installing furring strips. The cap nails also mark the location of framing.
- Using broken thread fasteners (fasteners with an unthreaded section of the shaft that allows the fastener to be firmly set into the structure before threads engage the furring strip).
- Predrilling furring strips.

Methods that risk damaging the air and water control membrane, such as coring through the mineral fiber insulation board with a hole saw should be avoided.

3 Technical Description

3.1 High Performance Mineral Fiber Retrofit Assemblies

The high performance mineral fiber retrofit solutions are described in outline below.

3.1.1 Mineral Fiber Retrofit Roof Assembly

From interior to exterior the retrofit roof assembly is as follows (see Figure 1 and Figure 2):

- Fibrous cavity insulation (SPF also acceptable with conditions)
- Existing roof sheathing
- Air and water control membrane
- Mineral fiber insulation board as needed for condensation control and high R-value performance
- Sheathing (for cladding attachment) fastened to structure through the mineral fiber insulation sheathing. Where roof cladding is vented, furring strips are used.
- Water control membrane (underlayment and ice and water membrane)
- Roofing (shingles).

Note that some variations are inherent with different roof cladding systems such as metal or tile roof cladding.

3.1.2 Mineral Fiber Retrofit Wall Assembly

From interior to exterior the retrofit wall assembly is as follows (see Figure 3 and Figure 4):

- Existing interior finish
- Fibrous cavity insulation (SPF also acceptable with conditions)
- Existing wall sheathing
- Air and water control membrane
- Mineral fiber insulation board with R-value per Table 8 for condensation control and high R-value performance
- 1 × 4 furring strips fastened to the structure through the mineral fiber insulation board
- Cladding and trim.

The foundation retrofit strategy also includes groundwater and roof runoff control measures. A ground roof of rubber roofing or similar material is installed at the bottom of the excavation and sloped to a perforated drainpipe that is routed to a daylight outlet or to a storm water collection system. The drainpipe must not be connected to the foundation drain. In cold climates or in houses with crawlspaces or basements, non-moisture-sensitive insulation is placed over clean aggregate at the bottom of the excavation before the ground roof is installed.

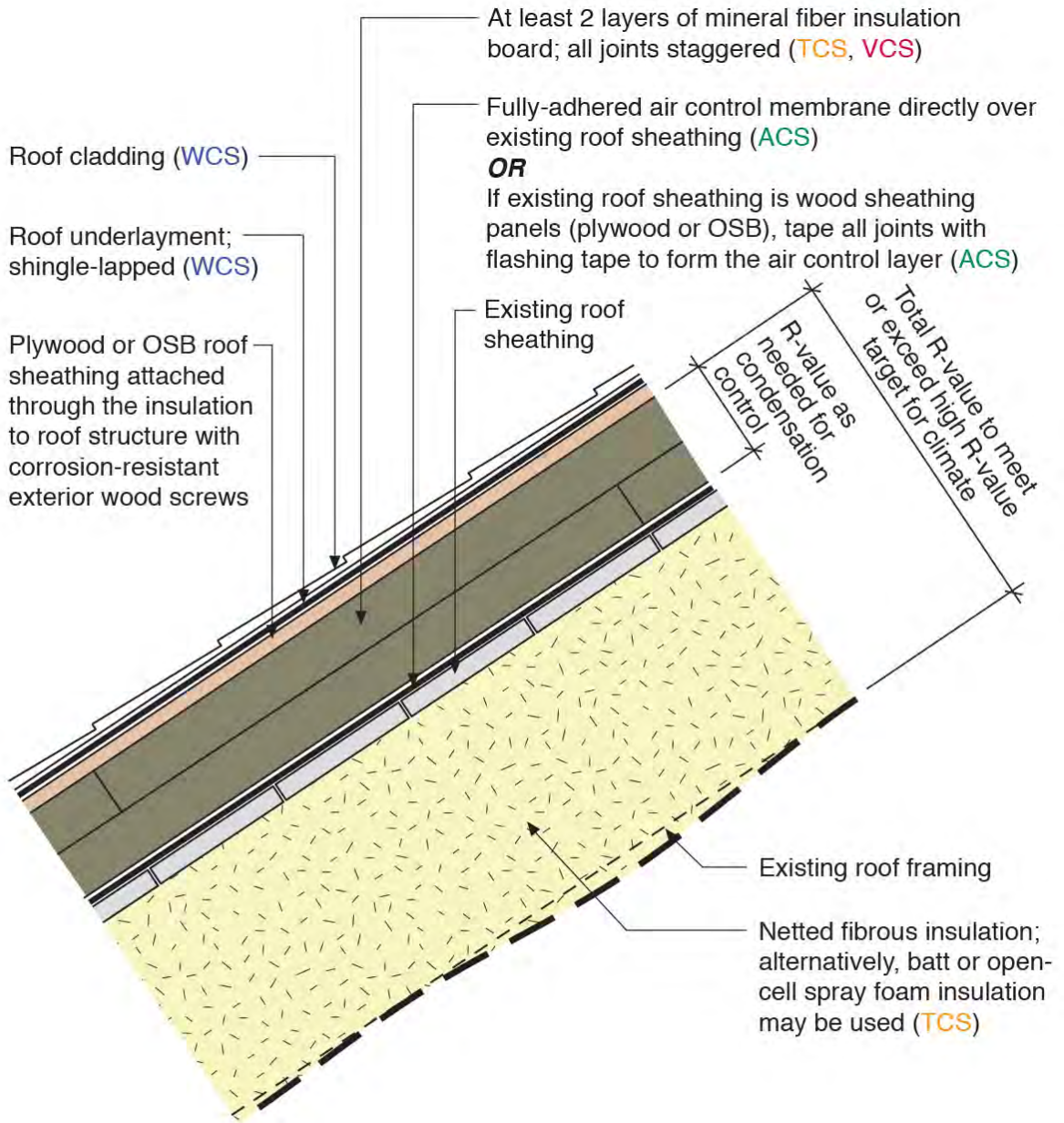



WCS	Water control system	TCS	Thermal control system		Gray tone indicates existing components
ACS	Air control system	CCS	Critter control system		Mineral fiber insulation board
VCS	Vapor control system				

Figure 1. Mineral fiber retrofit roof assembly

In high snow-load areas, a vented roof cladding is recommended. This alternative is shown in Figure 2 below.

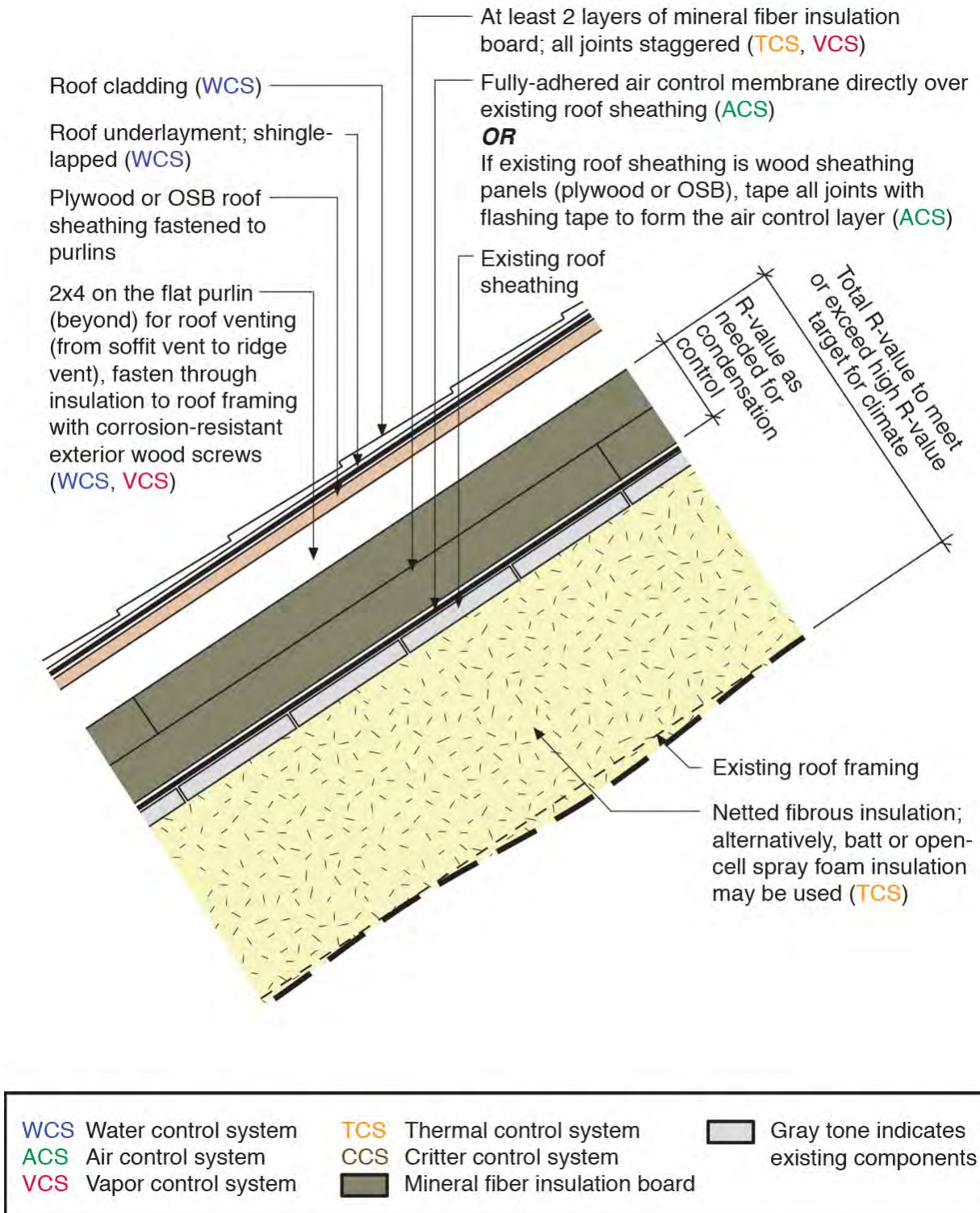

Figure 2. Mineral fiber retrofit roof assembly with a vented roof cladding

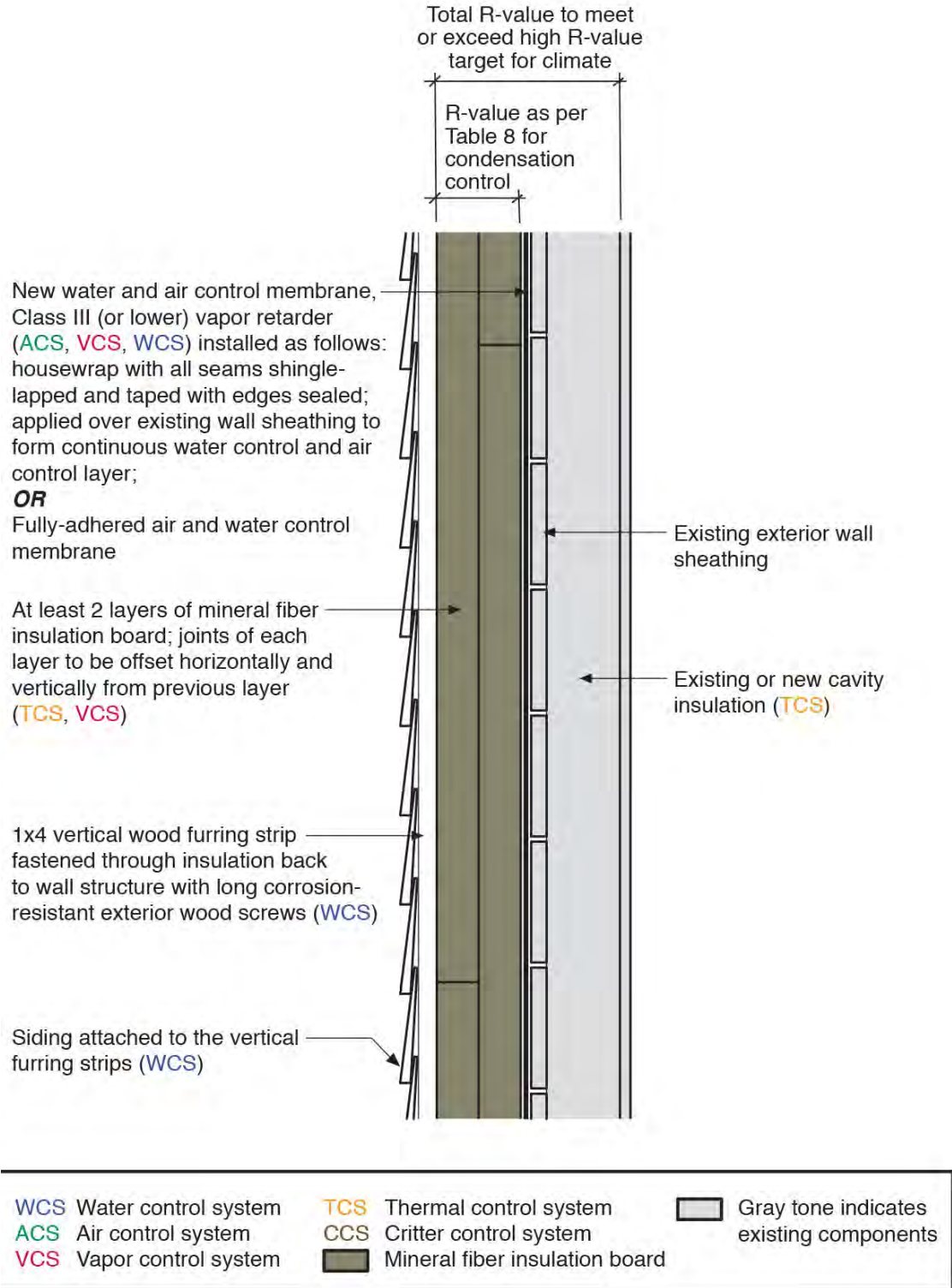
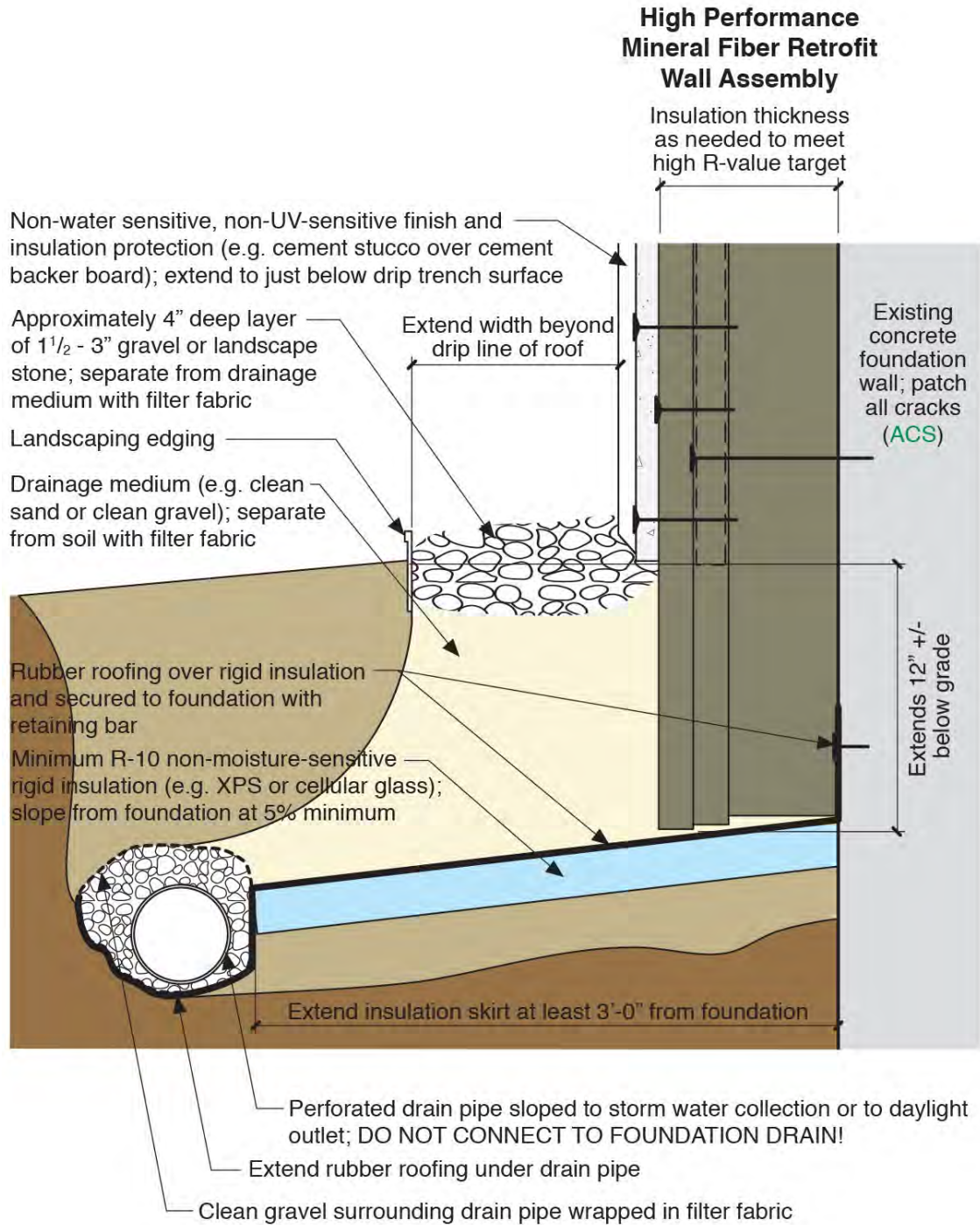

Figure 3. Mineral fiber retrofit wall assembly



WCS	Water control system	TCS	Thermal control system	Gray tone indicates existing components
ACS	Air control system	CCS	Critter control system	
VCS	Vapor control system		Mineral fiber insulation board	

Figure 4. Insulated ground roof included with mineral fiber retrofit foundation wall approach

3.2 Material Properties and Criteria for Mineral Fiber Insulation Board

Table 7 lists the material properties necessary or assumed for the mineral fiber retrofit solutions described in this Measure Guideline.

Table 7. Material Properties and Criteria for Mineral Fiber Insulation Board

Material Property	Criteria	Relevant Standard
Density	Approximately 8/ft ³	
Compressive Resistance	5/ft ² at 10% deformation, 8/ft ² at 8% deformation	
Hydrophobic	moisture sorption 0.1%	ASTM C1104
Thermal Resistance	R-value 3.8–4.3/in.	
Stone Wool		
Melting Temperature	> 2,000°F	
	non-combustible at 750°F	ASTM E136
Flame Spread	< 5	ASTM E84
Smoke Development	≤ 10	ASTM E84
Water Vapor Permeance	~30 U.S. perms @ 2 in. thickness	
Coefficient of Thermal Expansion	< 5 10 ⁻⁶ in./in./°F	

3.3 System Interaction

This is a high performance retrofit solution. Approaching from the exterior side, as this retrofit solution does, presents an opportunity to completely overhaul the major building enclosure functions—water control, air control, vapor control, and thermal control—of the above-grade enclosure so that it can provide a very high level of performance well into the future. In keeping with this opportunity, the retrofit solutions outlined in this Guide include robust water, air, and vapor control measures in addition to high R-value thermal performance. The solutions outlined also have the potential to benefit the building enclosure’s “critter” (insect and rodent) control performance.

The performance of the mineral fiber retrofit solutions relative to critical control functions is described below.

3.3.1 Water Control

3.3.1.2 Water Control in Mineral Fiber Retrofit Roof Solution

In the retrofit roof assembly, the new roofing installed above insulation board provides the primary water control. The air control membrane installed over the existing roof sheathing is recommended to be detailed as a water control (backup and construction phase water control) membrane.

Vented Roof Option

Where the ground snow load is 50/ft³ or greater, a vented roof cladding is recommended as a method to further control ice dam formation.

To prevent ice dams in high snow load areas (areas with > 50/ft² ground snow load) the roof cladding nail base sheathing should be vented above the insulation

board. Vented roofing is accomplished with 2 × 4 on the flat purlins installed between the insulation board and the nail base sheathing and then providing eave and ridge vents. Note that purlins need not be continuous from the eave to the ridge. Breaks in the purlins can allow for cross-ventilation as would facilitate ventilation of complex roofs involving hips, valleys, or interruptions such as dormers and skylights.

3.3.1.2 *Water Control at the Roof-to-Wall Transition*

The roof overhangs provide the transition of bulk water control at the roof-to-wall transition.

Critical Takeaway

Through-wall and kick-out flashings need to be extended to accommodate the added thickness of insulation and furring strips.

For the transition from a wall to a lower roof, see the details in Section 4.

3.3.1.3 *Water Control in Mineral Fiber Retrofit Wall Solution*

The mineral fiber insulation board material, although hydrophobic, is not suitable for creating a drainage plane at the surface of the insulation as may be done with foil-faced PIC or XPS insulation board. Instead, a water control membrane is installed on the face of the existing sheathing (in a manner similar to new construction) to serve as the drainage plane/water control layer. Flashings are then integrated with this drainage plane.

The flashing details for this system are very similar to those provided in Baker (2012) for “Exterior Insulation over Wood Frame Wall Drainage Plane at Face of Wood Frame.”¹

Some flashings such as kick-out flashing or through-wall flashings that are intended to direct water from the drainage plane out over the face of the cladding will need to anticipate the added thickness of the insulation and furring strips.

3.3.1.4 *Water Control at the Wall-to-Foundation Wall Transition*

The transition of bulk water control at the wall-to-foundation wall transition is provided by a sloped metal closure/flashing at the base of the wall retrofit assembly or top of the foundation wall retrofit assembly.

3.3.1.5 *Water Control in Mineral Fiber Retrofit Foundation Wall Solution*

At the foundation wall, this retrofit solution enhances the control of roof runoff and surface water near the foundation wall, as shown in Figure 6. The retrofit assembly for the foundation includes mineral fiber insulation and cladding at the above-grade portion of the wall as well as a “ground roof” or “skirt” with a drainpipe below grade. The treatment on the above-grade surface of the foundation wall prevents splash-back and other minor surface water from being absorbed into the foundation by capillary action. The retrofit assembly also allows for some drying of moisture (e.g., capillary moisture from groundwater) from the foundation wall. The ground roof intercepts

¹ The details for exterior insulation with drainage plane at the face of wood framing appear in Appendix A to Baker’s report on pages 63–78.

roof runoff and surface water that is draining near the foundation and directs this water into a drainpipe that conveys it to daylight or a drywell. This drainpipe must NOT be connected to an existing foundation drain, because this would result in charging the foundation drain system with roof runoff and groundwater.

Clean stone in a drip trench adjacent to the foundation wall provides a capillary break between the soil and the protective insulation finish. This capillary break is important for protecting finish material, such as stucco, that is not appropriate for ground contact. The stone also serves to dissipate the energy of rain or roof runoff, thereby limiting splash-back.

A capillary break of clean aggregate is also needed under the rigid insulation used in an insulated ground roof/insulated foundation skirt.

This retrofit approach involves only a shallow excavation around the perimeter of the building rather than a full excavation of the foundation walls. The retrofit measures significantly improve water management, but the home may still require measures at the interior such as a sump pump or an interior perimeter drain to manage elevated groundwater.

3.3.2 Air Control

3.3.2.1 Air Control in Mineral Fiber Retrofit Wall and Roof Solutions

Mineral fiber insulation is not an air barrier material. In the mineral fiber retrofit assembly for the wall and roof, air control is established at the face of the existing sheathing. Often the water control membrane can be detailed to serve as both a water control and an air control layer. In cases where the sheathing is wood panels (OSB or plywood), it may be possible to establish the air control layer at the wood sheathing by taping the seams and sealing penetrations through the sheathing. Wood panels may also be added to a roof or wall to serve as an air control membrane. In some cases, adding wood panel sheathing of sufficient thickness over existing wood sheathing can create a continuous layer of adequate wood thickness for fastener embedment (typically 1 ½ in. is required).

3.3.2.2 Air Control at the Roof-to-Wall Transition

With the “chainsaw” retrofit configuration, the air control membrane of the roof connects directly to the air control membrane of the wall.

For a non-chainsaw configuration, a sheathing infill extends from the top of the existing wall sheathing to the underside of the roof sheathing. This infill sheathing is sealed to the roof sheathing, sealed to the air control layer of the wall, and sealed around all penetrations through the plane of the infill sheathing/wall sheathing.

For the transition from a wall to a lower roof, see the details under Measure Implementation.

3.3.2.3 *Air Control at the Wall-to-Foundation Wall Transition*

At the base of the frame wall, the air control membrane is adhered to or sealed to the bottom of the wall sheathing. The bottom of the wall sheathing is sealed to the foundation wall.

3.3.2.4 *Air Control in Mineral Fiber Retrofit Foundation Wall Solution*

With a cast concrete foundation wall, the foundation wall typically provides the air control layer for the assembly. Holes and cracks in the cast concrete foundation wall must be patched and sealed. With foundation walls constructed of block, brick, or field stone, effective air control relies upon an air control membrane applied at the interior of the foundation wall.

3.3.3 *Vapor Control*

Insulation board makes the framing cavity more similar to the conditioned interior. During the heating season, insulation board makes the framing cavity and sheathing warmer and drier. During cooling seasons or periods of air conditioner use, insulation boards make the framing cavity and sheathing colder and *potentially* wetter. Especially in a building that uses air conditioning, but even in a cool climate where air conditioning will not be used, drying to the interior is important. Drying to the interior can be inhibited by interior-side vapor retarders such as polyethylene, foil-facing or kraft facing on insulation, vinyl wall coverings, tiles, or even multiple layers of paint. In a retrofit situation, the presence or absence of interior-side vapor retarders may not be known without opening an exterior wall. Exploratory openings should be made, if needed, to determine the existing enclosure assembly configuration.

Super-insulated wall and roof assemblies that use thick exterior insulation board usually have sufficient insulation to the exterior of the sheathing to control condensation of interior water vapor. The amount of insulation needed to the exterior of the sheathing to control this condensation is determined by a number of factors. The dew point of the interior air determines the critical temperature above which the sheathing must be maintained. The temperature of the sheathing is determined by the outdoor temperature, the indoor temperature, and the part of the total assembly R-value that is to the exterior of the sheathing. Infrequent and short-lived condensation conditions are typically not a concern for sheathing materials with reasonable moisture tolerance such as OSB, plywood, or board sheathing. Condensation that accumulates and is sustained over a significant period of time is a concern. Design for air leakage condensation control in this context can use the average temperature of the three coldest months for a particular location as the outdoor temperature condition. Table 8 shows the ratio of exterior insulation R-value to total assembly R-value needed to control the temperature of sheathing above the dew point of interior air given interior air at 68°F.

Table 8. Ratio of Exterior Insulation to Total Assembly Insulation for Air Leakage Condensation Control at 68°F Indoor Temperature

(adapted from Straube 2011)

	Indoor Relative Humidity (%)	20	25	30	35	40	50	60
	Dew Point of Interior Air (°F)	26.6	32	36.6	40.5	44	49.9	54.8
Outdoor Temperature (°F)	Ratio of Exterior Insulation R-Value to Total Assembly R-Value for Condensation Control							
50		0	0	0	0	0	0	0.24
41		0	0	0	0	0.1	0.31	0.48
32		0	0	0.12	0.23	0.32	0.47	0.6
23		0.08	0.19	0.29	0.37	0.45	0.57	0.68
14		0.23	0.32	0.4	0.48	0.54	0.64	0.73
5		0.33	0.42	0.49	0.55	0.6	0.69	0.77
-4		0.41	0.49	0.55	0.6	0.65	0.73	0.8
-13		0.48	0.54	0.6	0.65	0.69	0.76	0.82
-22		0.53	0.59	0.64	0.68	0.72	0.78	0.84

1. Vapor Control in Mineral Fiber Retrofit Roof Solution

Outward vapor drive is controlled in the roof assembly by insulation to the exterior of existing roof sheathing. It is important to maintain sufficient ratio of exterior insulation (insulation board) to total roof assembly insulation. Table 8 shows the ratio of insulation needed for various interior humidity conditions and an interior temperature of 68°F.

<p>Key Point</p> <p>For vapor control in a hot-humid climate, the air control membrane over the existing sheathing must be a class II (or lower) vapor retarder and must also be a water control membrane.</p>

Inward vapor drive must be managed for all roofs. In roof assemblies with plywood or board sheathing and fibrous cavity insulation and no interior-side vapor retarders the inward vapor drive is managed by allowing drying to the interior. However, if the roof assembly includes significant vapor retarders on the interior side of the roof cavity, closed-cell foam insulation (SPF or board foam) to the interior of the structural sheathing, or OSB sheathing, then additional vapor control measures are needed. In hot-humid climates, the air control membrane installed above the existing roof sheathing must be a class II (or lower) vapor retarder and also be a water control membrane. In other climates, the air control membrane should be a class III (or lower) vapor retarder. Information about classes of vapor retarders has been provided by Lstiburek (2011).

3.3.1 Vapor Control at the Roof-to-Wall Transition

See Section 3.3.4.2.

3.3.2 Vapor Control in Mineral Fiber Retrofit Wall Solution

Condensation caused by outward vapor drive is controlled in the wall assembly by insulating to the exterior of existing wall sheathing. The ratio of exterior insulation (insulation board) to total wall assembly insulation is critical to controlling the risk of condensation at the sheathing. The ratio needed varies with climate and interior conditions (see Figure 5). Table 8 shows the ratio of insulation needed for various interior humidity conditions and an interior temperature of 68°F.

The wall assembly manages inward vapor drive through a vented cladding and a water and air control membrane over the sheathing that is also a class III (or lower) vapor retarder. In hot-humid climates, a class II (or lower) vapor retarder over the sheathing is appropriate. For walls that have a non-reservoir cladding such as vinyl siding and that are located in either a dry or cold (climate zone 5 or above) climate, the class III vapor retarder is necessary with significant air conditioner use and interior-side vapor retarders only.

Limiting the Impact of Reservoir Claddings

The water uptake of reservation claddings can be significantly reduced by preventing water from reaching the surface of the cladding. For example, large overhangs can shield the cladding from incident rain water. Paints and coatings can also block the capillary pores that wick water into the material. For wood and fiber cement cladding, it is important to prime or paint all sides of the cladding pieces—including cut ends—to limit the uptake of water through capillary action.

Insulation for Condensation Control

To control condensation of interior water vapor, the sheathing must be maintained above the dew point of the interior air. The temperature of the sheathing is determined by the indoor and outdoor temperature and by the ratio of insulation outside of the sheathing to insulation inside of the sheathing. As the outdoor temperature decreases, the amount of insulation needed to maintain the sheathing temperature increases. Also, as the interior humidity increases the dew point temperature of interior air increases, so the sheathing must be maintained at a higher temperature to avoid condensation.

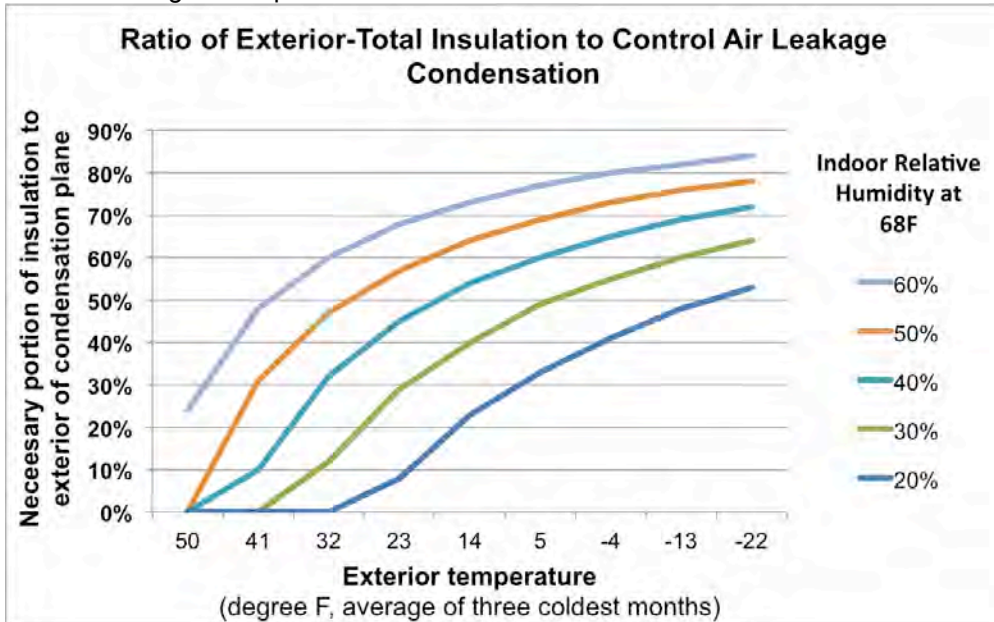

Figure 5. Ratio of exterior to total insulation to control condensation of interior water vapor

3.3.3 Vapor Control at the Wall-to-Foundation Wall Transition

See Section 3.3.4.2.

3.3.4 Vapor Control in Mineral Fiber Retrofit Foundation Wall Solution

The foundation retrofit assembly permits drying from the foundation wall into the mineral fiber exterior insulation. Whether moisture is able to dry to the exterior depends upon the properties of the protective finish selected for the above-grade part of the mineral fiber insulation. A sheet metal covering would not allow diffusion drying but condensate could safely drain away between the metal covering and the insulation board.

The interior of the foundation wall may still present a condensation surface when interior air dew point exceeds the ground temperature. Also, the part of the foundation wall below the foundation skirt will remain exposed to ground moisture. Comprehensive vapor management for foundation walls may require additional measures to the interior of the foundation wall.

3.3.4 Thermal Control

Table 1 provides the thermal resistance (R-value) targets for the enclosure components addressed in this guide. The “Basement Wall” targets define the performance criteria for exterior insulation of the foundation wall. The target performance for the insulated foundation skirt (used in cold climates or where the home has a crawlspace or basement) is given by the targets for “Slab Edge” insulation in the table.

3.3.4.1 Thermal Control in Mineral Fiber Retrofit Roof Solution

The retrofit roof assembly is thermally controlled by insulation board, usually in combination with cavity insulation directly to the underside of the sheathing. It is important that the ratio of exterior insulation board to total assembly thermal resistance is as needed to control condensation. See Section 3.3.1.

3.3.4.2 Thermal Control at the Roof-to-Wall Transition

In a “chainsaw” configuration, the continuity of thermal control is inherently achieved by direct connection between roof insulation board and wall insulation board. In cold climates, continuous insulation at the transition is important to the control of condensation or elevated relative humidity at the thermal bridging elements represented by framing.

In non-chainsaw configurations, the roof insulation board is continuous onto the overhang. The wall insulation board is fit around projecting framing and butted to the roof sheathing. Closed-cell SPF is used to complete the transition of air, vapor, and thermal control at non-chainsaw roof-to-wall transitions.

For the transition from a wall to a lower roof, see the details in Section 4.

3.3.4.3 Thermal Control in Mineral Fiber Retrofit Wall Solution

The retrofit wall assembly is thermally controlled by insulation board, usually in combination with insulation in the framing cavities of exterior walls. It is important that the ratio of exterior insulation board to total assembly thermal resistance is as needed to control condensation. See the Section 3.3.4.

3.3.4.4 Thermal Control at the Wall-to-Foundation Wall Transition

Metal flashing at the base of the wall represents a thermal bridging element with respect to the insulation board. When connected to the mass of the foundation wall, the impact is dispersed and should not represent a specific cold-weather condensation risk.

The bottom of the exterior wall retrofit assembly should extend past the bottom of the wood sheathing where possible to ensure that the sheathing is maintained closer to the interior conditions.

Continuity of the thermal control is improved by cutting the bottom of the wall insulation board and the top of the foundation wall insulation board on an angle to fit snug against the sloped metal flashing/closure between the foundation and wall exterior retrofit treatments.

3.3.4.5 Thermal Control in Mineral Fiber Retrofit Foundation Wall Solution

The insulation board installed at the exterior exposed part of the foundation wall should at least meet the high R-value target for basement walls. This is true even if the interior is insulated as the exterior exposed part of the foundation wall represents a more significant heat transfer surface than the below-grade (by more than 1 ft) sections. To the extent that a significant part of the foundation wall remains in contact with ground below the exterior insulation treatment, the foundation wall will remain significantly ground coupled. Therefore, additional insulation to the interior may be warranted to improve comfort conditions.

The R-value of the insulated foundation skirt (used in cold climates or where the home has a crawlspace or basement) should be at least as given by the targets for “slab edge” insulation in the table. Because of the position of the foundation skirt insulation, the insulation material must be a rigid material with robust compressive strength and the material must be non-moisture sensitive. XPS and foamed glass rigid insulation are appropriate materials for this application. Even with these relatively non-moisture-sensitive materials, the insulation is recommended to be laid over a capillary break of clean aggregate.

3.4 Climate Considerations

Mineral fiber insulation board is a vapor-permeable material that supports outward drying of assemblies. Because of its high vapor permeability the material offers negligible resistance to inward vapor drive. Inward vapor drive occurs when the ambient air is humid and the interior of the enclosure is cooler than ambient air. This condition is typical of buildings when air conditioning is in operation. It is a sustained condition in hot-humid climates.

Inward vapor drive also occurs—and can be significant—when a wetted reservoir cladding is exposed to direct solar radiation. This type of inward vapor drive can affect buildings with reservoir claddings regardless of the climate.

Inward vapor drive presents a risk to moisture-sensitive materials located in a part of the assembly where it would lead to condensation or elevated relative humidity.

To provide control of exterior water vapor, a class III (or lower) vapor retarder between mineral fiber insulation board and sheathing is the base recommendation for mineral fiber framed assembly retrofit solutions. In hot-humid climates, a class II (or lower) vapor retarder over the sheathing is recommended.

For walls that have a non-reservoir cladding, such as vinyl siding, and that are located in either a dry or cold (climate zone 5 or above) climate, the class III vapor retarder is necessary with significant air conditioner use and interior-side vapor retarders only.

4 Measure Implementation

4.1 High Performance Mineral Fiber Retrofit Roof Assembly

4.1.1 Scope of Work

1. Remove roof cladding and prepare the roof sheathing for air and water control membrane.
2. Implement a “chainsaw” retrofit where structural configuration of the roof permits.
3. Install a continuous air and water control membrane over the roof sheathing to provide vapor control in accordance with code. Transition the roof air and water control membrane to adjacent assemblies.
4. Install mineral fiber insulation board in accordance with code to satisfy the high R-value performance target for the assembly and for adequate condensation control (the higher R-value requirement shall govern).
5. Install sheathing as a nail base for roof cladding. Fasten the sheathing to the roof structure through the insulation board.
OR
Install purlins for ventilated roof sheathing. Fasten the purlins to the roof structure through the insulation board. Install sheathing as a nail base for roof cladding. Fasten the sheathing to the purlins.
6. Install roof underlayment, ice and water membrane, flashing, and roofing per new construction best practices.

4.1.2 Climate-Specific Factors

In hot-humid climates, the air and water control membrane between the mineral fiber insulation board and the roof/wall sheathing must be a class II (or lower) vapor retarder.

4.1.3 Field Inspection

Identify and address risks to occupants or the building that could be aggravated by the work. Verify safe working conditions. Determine whether the building has more urgent problems that must be addressed. Determine the feasibility of the retrofit solution and of options.

Inspect and assess the building for:

- Structural integrity of the frame and foundation
- Safety and serviceability of the electrical system
- Hazardous materials (e.g., lead, radon, asbestos)
- Rainwater, groundwater, or plumbing water leaks
- Rot or decay in framing
- Insect and pest damage and activity.

Deficiencies or hazards must be remediated before the project begins, or remediation must be incorporated into the scope of the project.

Identify any atmospherically vented (or naturally aspirated) combustion appliances in the home. With the exception of gas stoves and cooktops, combustion appliances—including fireplaces—should be direct-vented or direct exhaust-vented equipment. Atmospherically vented appliances must be replaced or reconfigured to direct-vented or direct exhaust-vented operation prior to or as part of the project.

Verify that all kitchen and bathroom exhausts are vented to the exterior of the building. Source control ventilation deficiencies must be corrected either prior to or as part of the project.

If the home lacks a ventilation system meeting the requirements of 2012 IRC, Section M1507.3, a ventilation system meeting this requirement must be installed either prior to or as part of the project.

4.1.4 Implementation Risks

Construction and renovation work entails inherent risks to workers. All applicable safety procedures must be followed.

Implementation risks specific to mineral fiber insulation board retrofit derive from the fibrous nature of the material. It is recommended that all workers handling or cutting material:

1. Wear protective clothing and avoid exposed skin.
2. Wear goggles or similar enclosed eye protection.
3. Wear gloves that are impermeable to fibers.
4. Use tight-fitting dust masks to provide appropriate protection from airborne fibers.
5. Refer to material safety data sheets and manufacturer instructions for safe handling and exposure.

4.1.5 Installation Procedure

1. Remove existing cladding and prepare the roof sheathing to receive the air and water control membrane.

Removal of roof cladding is a well-established procedure.

Appropriate preparation of the roof sheathing will depend upon the nature of the existing sheathing and the air control strategy pursued. If a sheet good is used as the air and water control

Ensuring Success

Significant retrofit of building enclosure components will change the dynamics of water, air, vapor, and heat flow within the home. To ensure that these changing dynamics do not have negative ramifications for health and safety or for building durability, the following conditions must be met either prior to or as part of the project.

- Combustion safety—All non-cooking appliances, including fireplaces, must be direct-vented or direct exhaust-vented appliances.
- Ventilation—Whole-house ventilation meeting the requirements of 2012 IRC, Section M1507.3 is installed and operational.

The following is also recommended:

- Soil gas control system—An active or passive soil gas control system is installed and operational.

layer, all protruding fasteners must be removed to avoid punctures or tears in the membrane. Gaps or voids in the sheathing layer may need to be filled. Use a primer for self-adhered membranes if recommended by the membrane manufacturer.

1a. Chainsaw retrofit: Remove roof overhangs.

If roof framing allows, remove roof sheathing, rafter tails, and gable rake framing to flush with the exterior wall sheathing. Provide structural sheathing infill and/or blocking as needed to allow wall sheathing plane to meet roof sheathing plane.

2. Install an air and water control membrane.

Install a continuous water and air control membrane.

OR

Tape the wood panel sheathing with flashing tape (acrylic or bituminous adhesive) to form a continuous air control membrane (see Figure 6) and install a water control membrane over the wood panel sheathing (see Figures 7 and 8).

Connect the air control membrane to the air control layer of adjacent assemblies in an airtight and durable manner (see Figures 7 and 8). Seal all penetrations against air and water leaks.

The air and water control membrane or water control membrane must provide vapor control as required: class II (or lower) in hot humid climates, class III (or lower) elsewhere. See Section 3.



Figure 6. Taped wood panel roof sheathing as air control membrane



Figure 7. “Chainsaw” transition of air and water control membrane



Figure 8. “Chainsaw” transition of air and water control membrane at rake

3. Install a mineral fiber insulation board.

Install over the air and water control membrane. Butt joints tight. When installing multiple layers, offset seams in two directions.

3a. Chainsaw retrofit: Install framing for new overhangs.

Install framing for new roof overhangs over continuous insulation board. Many contractors who have experience with “chainsaw” retrofits prefer to pre-assemble framing for new roof overhangs (see Figure 9).



Figure 9. Pre-assembled insulated roof overhang framing being lifted into place at a gable rake for a “chainsaw” retrofit

3b. Vented roof option: Install purlins for ventilation and attachment or roof sheathing.

For a vented roof, install 2×4 on the flat purlins over the insulation board and fasten through the insulation board to the roof structure. Purlins need not be continuous from the eave to the ridge. Breaks in the purlins can allow for cross-ventilation as would facilitate ventilation of complex roofs involving hips, valleys or interruptions such as dormers and skylights. A structural engineer should be consulted for sheathing/purlin attachment type and number used, because it will be based on wind loads and potential uplift.

4. Install roof sheathing/cladding.

Install roof sheathing to serve as a nail base for roof cladding (e.g., shingles). Attach the sheathing to the roof structure through insulation board.

In the vented roof approach, attach the roof sheathing to purlins.

5. Install roof cladding and flashing.

Install underlayment, ice and water membrane, flashings, and roofing per new construction best practices.

6. Install rafter cavity insulation.

Install insulation in framing cavities to the underside of the existing roof deck. Refer to Table 8 and calculated ratios to ensure that the level of insulation does not upset the ability of the exterior insulation to provide condensation control.

See Figure 10 through Figure 17 for details about this procedure.

4.1.6 High Performance Mineral Fiber Retrofit Details

Lap and seal a fully-adhered transition membrane from the existing roof sheathing to wall air control layer; the roof air control layer must overlap and be sealed to the transition membrane, as shown; (ACS)

OR

if the roof air control layer is a fully-adhered membrane, it can replace the separate transition membrane by lapping over and sealing onto the wall air control layer (ACS)

Extend roof insulation board to cover the top edge of the wall insulation board (TCS, VCS)

Extend new roof sheathing to cover new eave (WCS)

Install ice and water control membrane under roof underlayment as required by code (WCS)

Extend roof underlayment to edge of roof sheathing overlapping metal drip edge (WCS)

Install new framing as needed for new eave overhang (WCS)

Remove existing eave overhang at plane of wall to allow for air and thermal control layer continuity at roof to wall connection

Extend wall insulation board up to underside of roof insulation board (TCS, VCS)

High Performance Mineral Fiber Retrofit Roof Assembly

Roof air control layer
Roof water control layer

Netted fibrous insulation; alternatively, batt or open-cell spray foam insulation may be used (TCS)

Install structural sheathing infill piece to provide substrate for control layers and backing for roof cavity insulation

Wall air control layer

Wall water control layer

High Performance Mineral Fiber Retrofit Wall Assembly



WCS	Water control system	TCS	Thermal control system		Gray tone indicates existing components
ACS	Air control system	CCS	Critter control system		Mineral fiber insulation board
VCS	Vapor control system				

Figure 10. Schematic detail for “chainsaw” eave transition from a high performance mineral fiber retrofit roof assembly to a high performance mineral fiber retrofit wall assembly

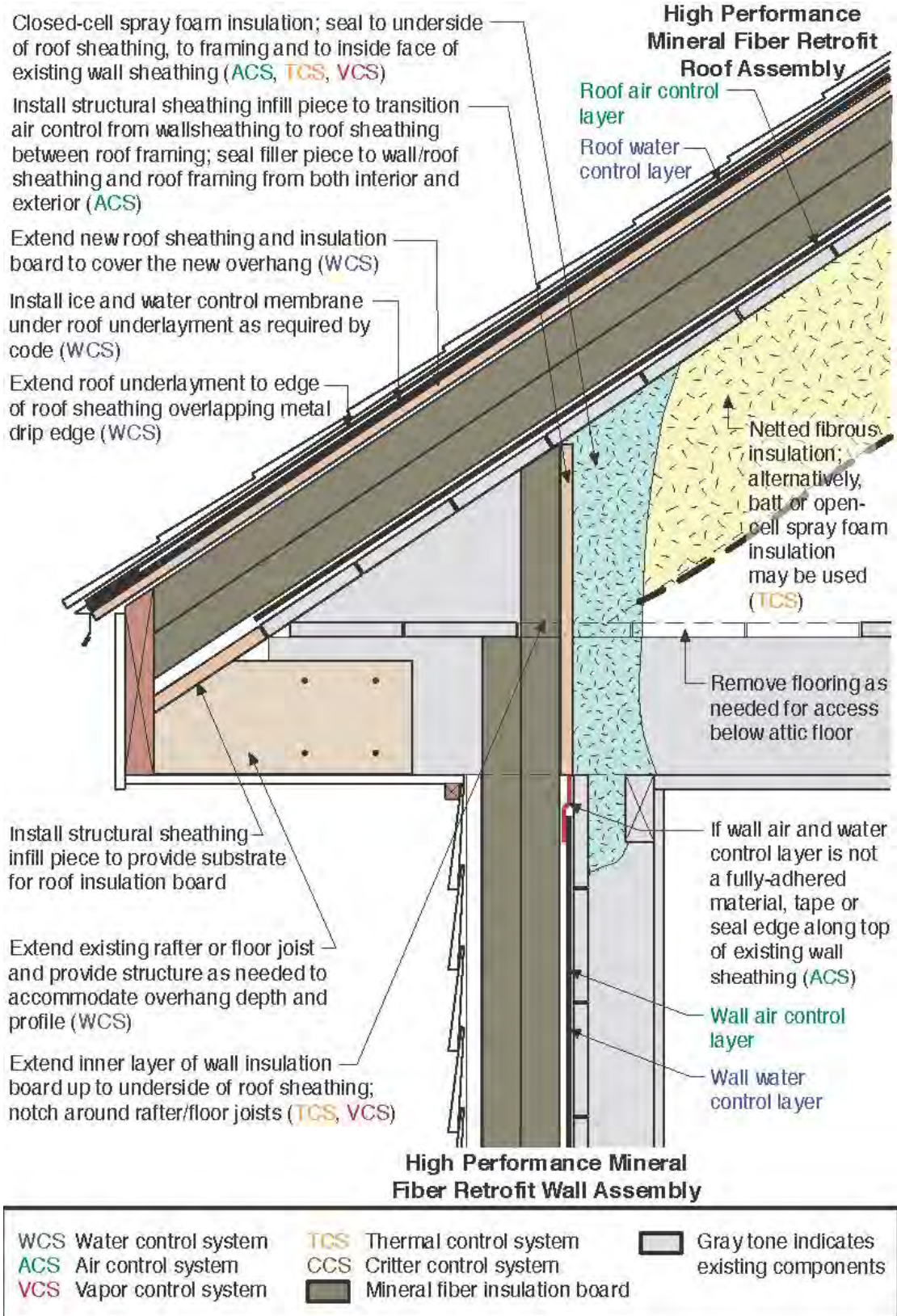

Figure 11. Schematic detail for non-“chainsaw” eave transition from a high performance mineral fiber retrofit roof assembly to a high performance mineral fiber retrofit wall assembly

Lap and seal a fully-adhered transition membrane from the existing roof sheathing to the wall air control layer; the roof air control layer must overlap and be sealed to the transition membrane, as shown; (ACS)

OR

if the roof air control layer is a fully-adhered membrane, it can replace the separate transition membrane by lapping over and sealing onto the wall air control layer (ACS)

Extend roof insulation board out to cover top of wall insulation board (TCS)

Extend new roof sheathing to cover new overhang (WCS)

Extend new roof underlayment to edge of roof sheathing overlapping metal drip edge (WCS)

2x ladder truss gable overhang extension attached to plywood behind (WCS)

Install 18" strip of 3/4" plywood above vertical furring strips along the rake; attach plywood back to wall framing; this serves as a nailer for the overhang structure as well as for the sloped ends of cladding

Extend wall insulation board up to underside of roof insulating sheathing at gable end (TCS)

Remove existing gable overhang; cut roof sheathing at face of existing wall sheathing; install structural sheathing infill piece, if needed, to provide substrate for control layers (ACS, TCS)

Install ice and water control membrane under roof underlayment at roof perimeter as required by code (WCS)

Roof water control layer

Roof air control layer

High Performance Mineral Fiber Retrofit Roof Assembly

Netted fibrous insulation; alternatively, batt or open-cell spray foam insulation may be used (TCS)

Existing or new wall cavity insulation (TCS)

Wall air control layer

Wall water control layer

High Performance Mineral Fiber Retrofit Wall Assembly

WCS	Water control system	TCS	Thermal control system	Gray tone indicates existing components
ACS	Air control system	CCS	Critter control system	
VCS	Vapor control system		Mineral fiber insulation board	

Figure 12. Schematic detail for “chainsaw” gable rake transition from a high performance mineral fiber retrofit roof assembly to a high performance mineral fiber retrofit wall assembly

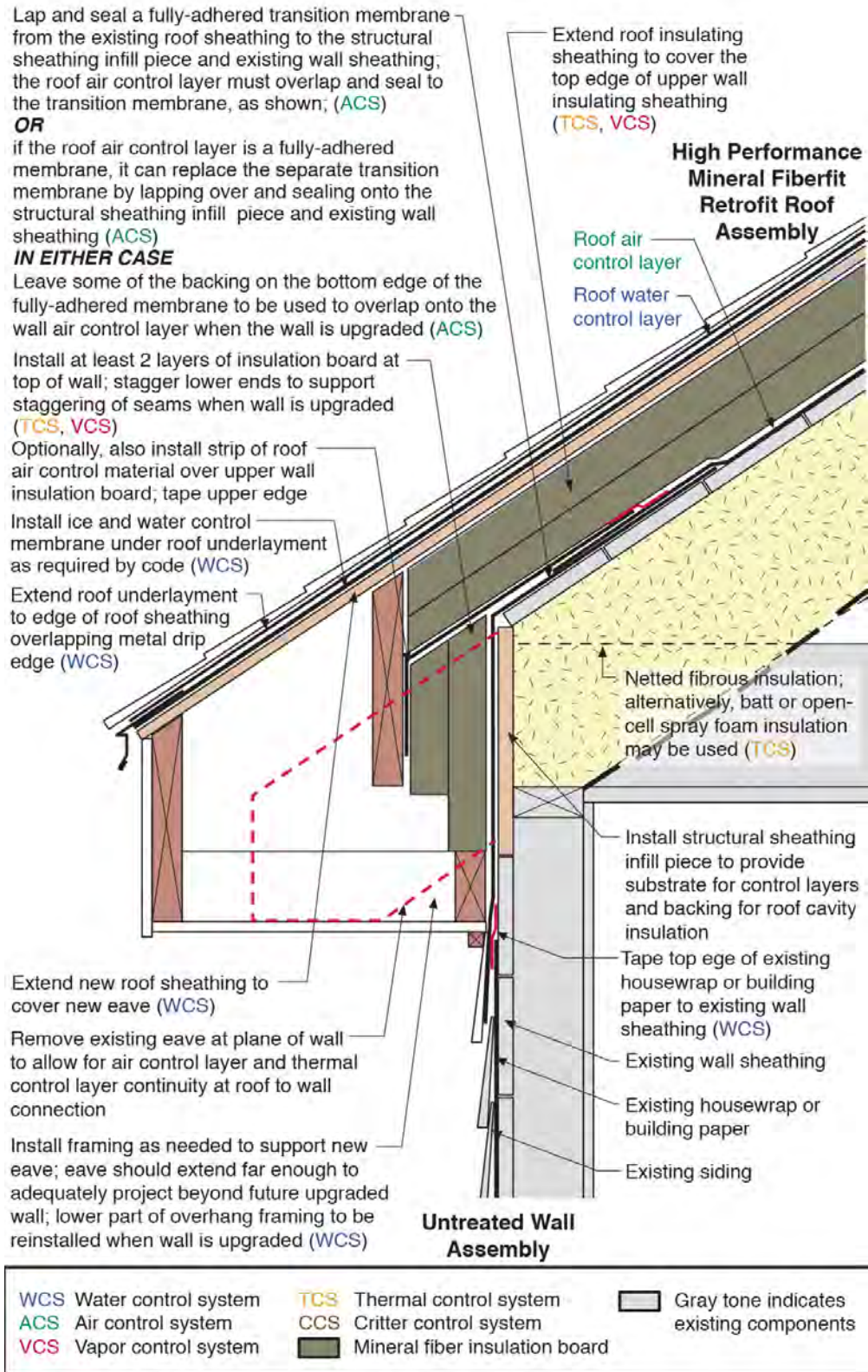

Figure 13. Schematic detail for “chainsaw” eave transition from a high performance mineral fiber retrofit roof assembly to a non-retrofit wall assembly

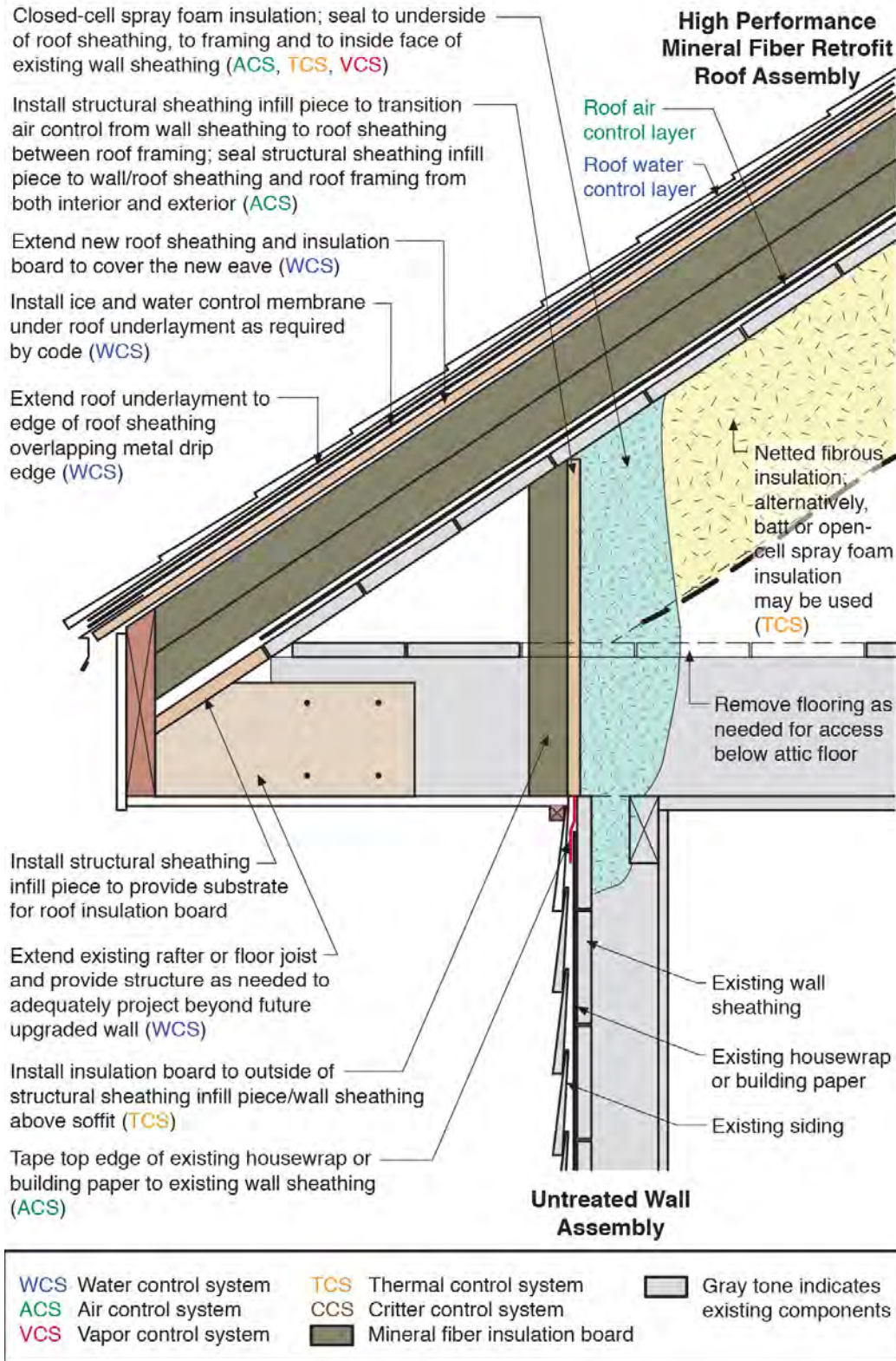

Figure 14. Schematic detail for non-“chainsaw” eave transition from a high performance mineral fiber retrofit roof assembly to a non-retrofit wall assembly

Lap and seal a fully-adhered transition membrane from the existing roof sheathing to the structural sheathing infill piece and existing wall sheathing; the roof air control layer must overlap and seal to the transition membrane, as shown; (ACS)

OR

if the roof air control layer is a fully-adhered membrane, it can replace the separate transition membrane by lapping over and sealing onto the structural sheathing infill piece and existing wall sheathing (ACS)

IN EITHER CASE

Leave some of the backing on the bottom edge of the fully-adhered membrane to be used to overlap onto the wall air control layer when the wall is upgraded (ACS)

Infill between ladder framing with rigid insulation (as at roof) (TCS)

Extend new roof sheathing to cover new overhang (WCS)

Extend new roof underlayment to edge of roof sheathing overlapping metal drip edge (WCS)

Install ice and water control membrane under roof underlayment at roof perimeter as required by code (WCS)

Roof water control layer

Roof air control layer

High Performance Mineral Fiber Retrofit Roof Assembly

2x ladder truss gable overhang extension; overhang should extend far enough to adequately project beyond future upgraded wall (WCS)

New fascia board or siding where existing overhang was removed

Remove existing gable overhang; cut roof sheathing at face of existing wall sheathing; install structural sheathing infill piece, if needed, to provide substrate for control layers (ACS, TCS)

Temporarily remove existing fascia board for access to top of existing wall sheathing

Netted fibrous insulation; alternatively, batt or open-cell spray foam insulation may be used (TCS)

Tape top edge of existing housewrap or building paper (WCS)

Existing or new gable wall cavity insulation (TCS)

Existing wall sheathing

Existing housewrap or building paper

Existing siding

Untreated Wall Assembly

WCS Water control system	TCS Thermal control system	Gray tone indicates existing components
ACS Air control system	CCS Critter control system	
VCS Vapor control system	Mineral fiber insulation board	

Figure 15. Schematic detail for “chainsaw” gable rake transition from a high performance mineral fiber retrofit roof assembly to a non-retrofit wall assembly

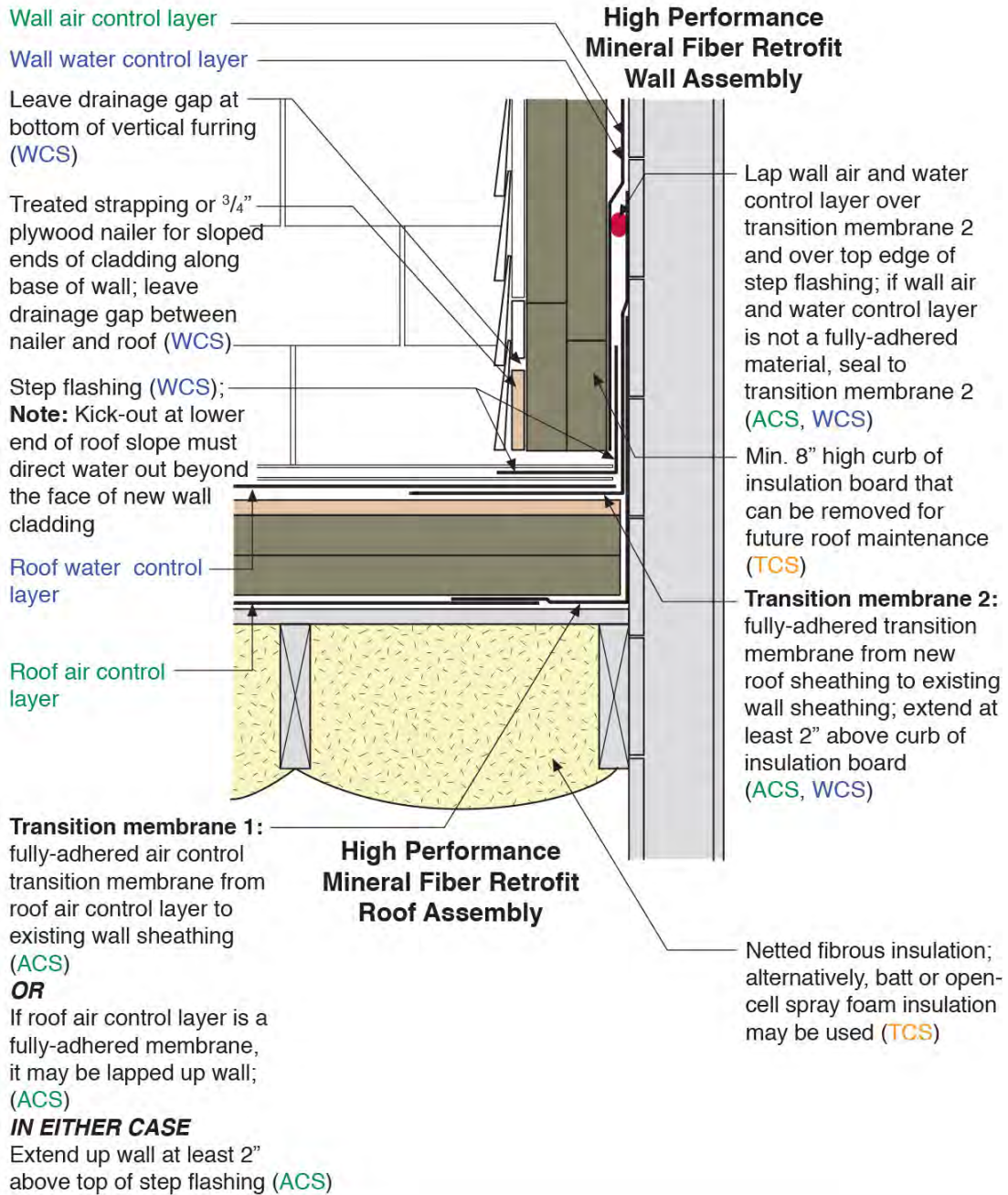

WCS	Water control system	TCS	Thermal control system	Gray tone	indicates existing components
ACS	Air control system	CCS	Critter control system		
VCS	Vapor control system		Mineral fiber insulation board		

Figure 16. Schematic detail for transition from a lower high performance mineral fiber retrofit roof assembly to a high performance mineral fiber retrofit wall assembly

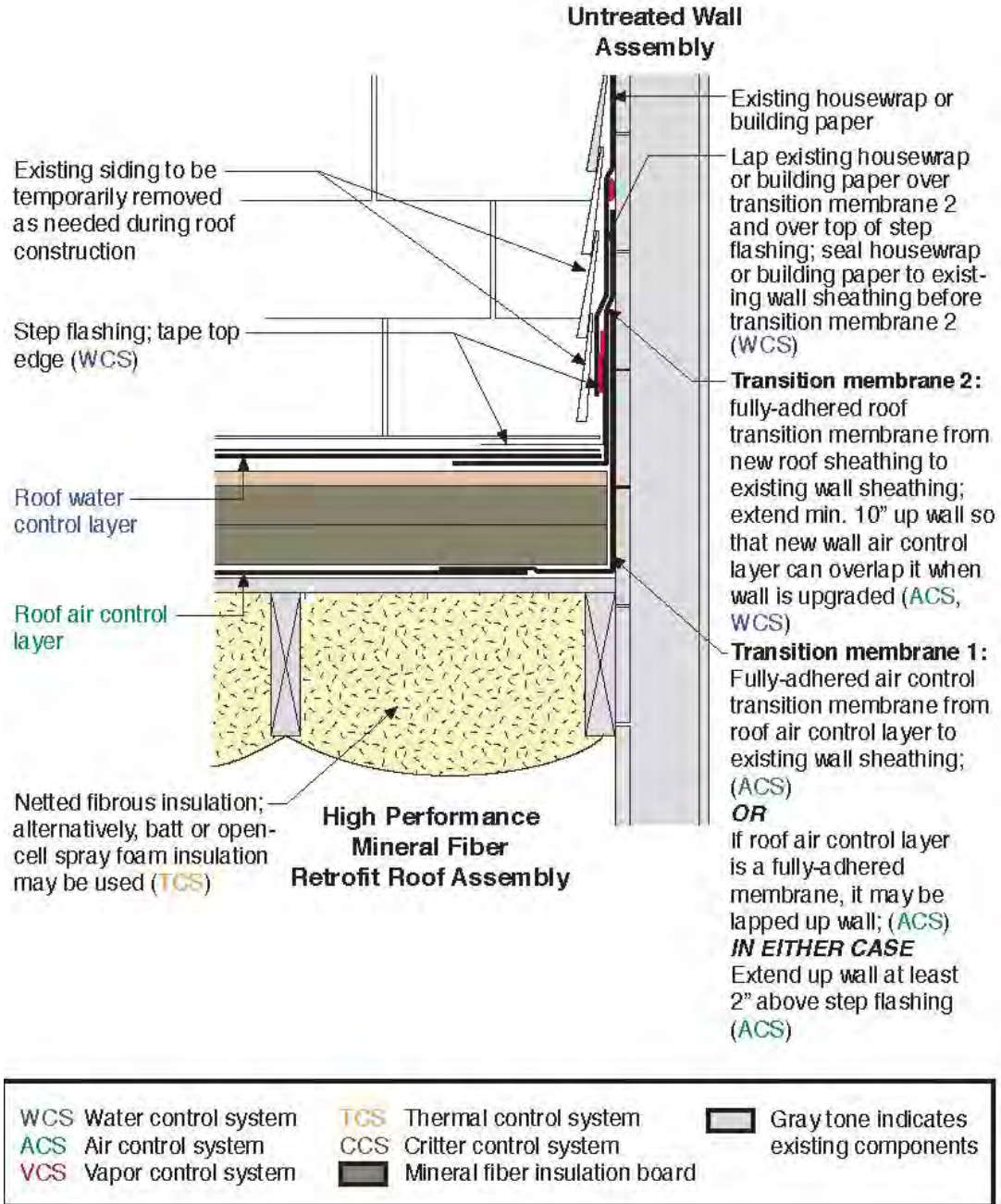

Figure 17. Schematic detail for transition from a lower high performance mineral fiber retrofit roof assembly to a non-retrofit wall assembly

4.2 High Performance Mineral Fiber Retrofit Wall Assembly

4.2.1 Scope of Work

1. Remove wall cladding and trim. Prepare the wall sheathing for the water and air control membrane.
2. Remove windows and doors as needed to allow flashing of openings and air control transitions into openings.

3. Install a continuous water and air control membrane over the wall sheathing to provide vapor control in accordance with code. Transition the wall air and water control membrane to adjacent assemblies.
4. Install flashings and air control transitions.
5. Reinstall windows and doors or install new windows and doors in properly flashed openings.
6. Install mineral fiber insulation board in accordance with code to satisfy the high R-value performance target for the assembly and for adequate condensation control (the higher R-value requirement shall govern).
7. Install furring strips over insulation board and attached to structure through insulation board. Install furring strips in a *vertical orientation only*.
8. Install wall cladding and trim. Attach to furring strips.

4.2.2 Climate-Specific Factors

In hot-humid climates, the air and water control membrane between the mineral fiber insulation board and the roof/wall sheathing must be a class II (or lower) vapor retarder.

4.2.3 Field Inspection

Identify and address risks to occupants or the building that could be aggravated by the work. Verify safe working conditions. Determine whether the building has more urgent problems that must be addressed. Determine the feasibility of the retrofit solution and of options.

Inspect and assess the building for:

- Structural integrity of the frame and foundation
- Safety and serviceability of the electrical system
- Presence of hazardous materials (e.g., lead, radon, asbestos)
- Rainwater, groundwater, or plumbing water leaks
- Rot or decay in framing
- Insect and pest damage and activity.

Deficiencies or hazards must be remediated prior to or as part of the project.

Identify any atmospherically vented (or naturally aspirated) combustion appliances in the home. With the exception of gas stoves and cooktops, combustion appliances—including fireplaces—should be direct-vented or direct exhaust-vented equipment. Atmospherically vented appliances must be replaced or reconfigured to direct-vented or direct exhaust-vented operation prior to or as part of the project.

Verify that all kitchen and bathroom exhausts are vented to the exterior of the building. Source control ventilation deficiencies must be corrected either prior to or as part of the project.

If the home lacks a ventilation system meeting the requirements of 2012 IRC, Section M1507.3, a ventilation system meeting this requirement must be installed either prior to or as part of the project.

4.2.4 Implementation Risks

Construction and renovation work entails inherent risks to workers. All applicable safety procedures must be followed.

Implementation risks specific to mineral fiber insulation board retrofit derive from the fibrous nature of the material. It is recommended that all workers handling or cutting material:

1. Wear protective clothing and avoid exposed skin.
2. Wear goggles or similar enclosed eye protection.
3. Wear gloves that are impermeable to fibers.
4. Use tight-fitting dust masks to provide appropriate protection from airborne fibers.
5. Refer to material safety data sheets and manufacturer instructions for safe handling and exposure.

4.2.5 Installation Procedure

1. Remove existing cladding and trim. Prepare the wall sheathing to receive the air and water control membrane.

Removal of siding and trim is a well-established procedure. Also remove decking that is adjacent to the exterior wall as needed to allow for continuous insulation of the wall.

Appropriate preparation of the wall sheathing will depend upon the nature of the existing sheathing and the air control strategy pursued. If a sheet good is used as the air and water control layer, all protruding fasteners must be removed to avoid punctures or tears in the membrane. Gaps or voids in the sheathing layer may need to be filled. Use a primer for self-adhered membranes if recommended by the membrane manufacturer.

2. Remove windows and doors.

Typically, the windows and doors will need to be removed to allow proper flashing of the window and door openings and to permit the installation of air control transition membranes.

Ensuring Success

Significant retrofit of building enclosure components will change the dynamics of water, air, vapor, and heat flow within the home. To ensure that these changing dynamics do not have negative ramifications for health and safety or for building durability, the following conditions below must be met either prior to or as part of the project.

- Combustion safety—All non-cooking appliances, including fireplaces, direct-vented or direct exhaust-vented appliances.
- Ventilation—Whole-house ventilation meeting the requirements of 2012 IRC, Section M1507.3 is installed and operational.

The following is also recommended:

- Soil gas control system—An active or passive soil gas control system installed and operational.

3. Install and implement air and water control membrane.

Install a continuous water and air control membrane.

OR

Tape the wood panel sheathing with flashing tape (acrylic or bituminous adhesive) to form a continuous air control membrane and install a water control membrane over the wood panel sheathing.

Connect the air control membrane to the air control layer of adjacent assemblies in an airtight and durable manner. Seal all penetrations against air and water leaks.

The water and air control membrane or water control membrane must provide vapor control as required: class II (or lower) in hot humid climates, class III (or lower) elsewhere. See Section 3.

4. Install flashings and air control transitions.

Transition the air control into window and door rough openings and air seal all penetrations through the wall. Flash window and door rough openings as well as all wall penetrations.

5. Install windows and doors.

Reinstall windows and doors or install new windows and doors in properly flashed openings. Air seal window and door units to the air control transition membranes at the interior perimeters of window and door units.

6. Install mineral fiber insulation board.

Install over the air and water control membrane. Butt joints tight. When installing multiple layers, offset seams in two directions. Until furring strips are installed, mineral fiber insulation board pieces can be held in place with cap nails or screws with roofing washers.

7. Install furring strips.

Install furring strips over insulation board and attached furring strips to the wall structure through the insulation board. Install furring strips in a *vertical orientation only*. It is important to install furring strips in a vertical orientation only to allow drainage from behind the cladding/trim and to prevent water from dwelling within the system. With mineral fiber insulation board 1 × 4 furring is recommended. The furring need not be preservative treated for moisture protection.

The spacing of fasteners through the furring strips must be such that the cladding load is distributed to no more than 10 lb per fastener.

8. Install cladding and trim.

Attach the wall cladding and trim to the vertical furring strips.

See Figure 18 through Figure 31 for details about this procedure.

4.2.6 High Performance Mineral Fiber Retrofit Details

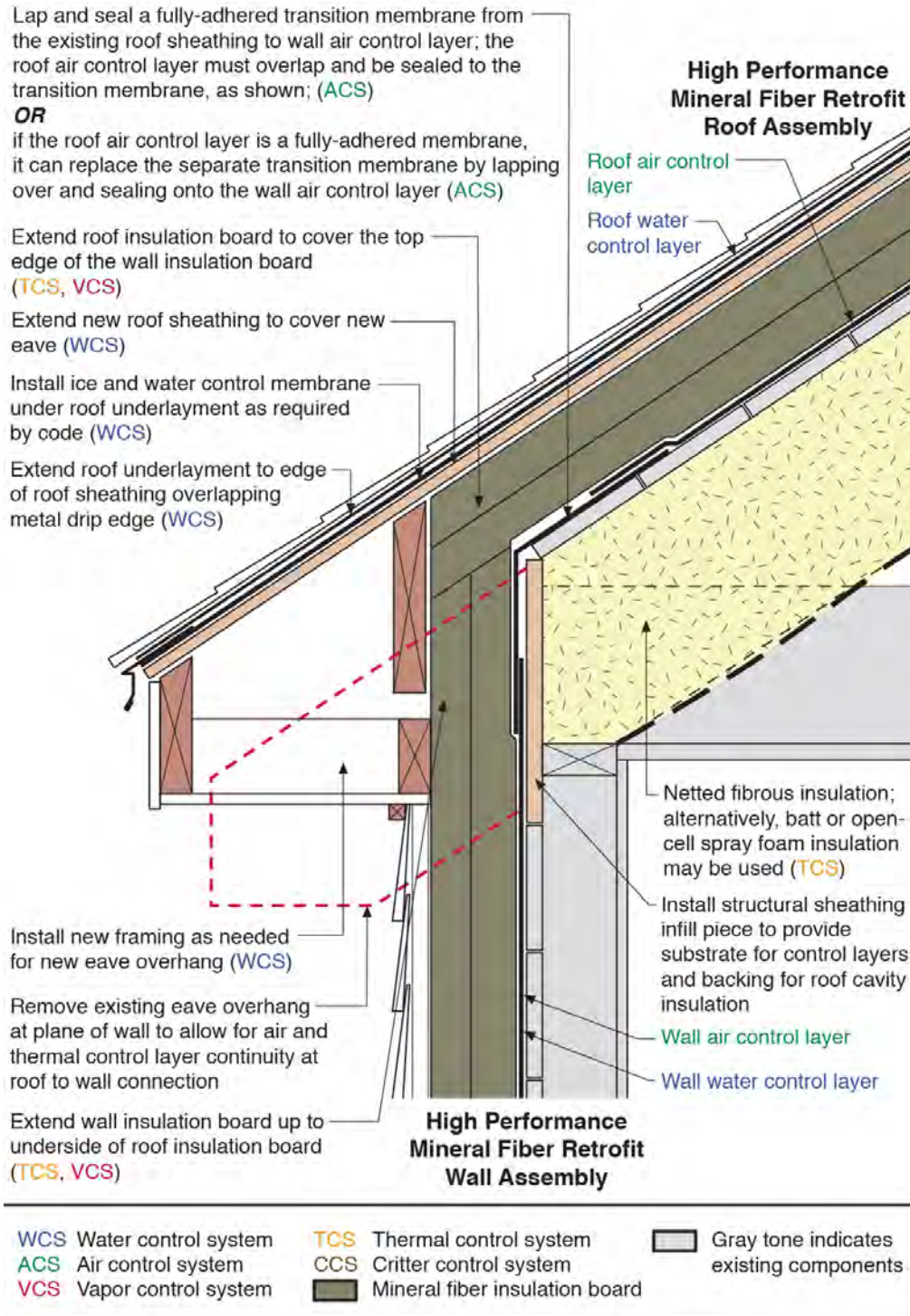

Figure 18. Schematic detail for “chainsaw” eave transition from a high performance mineral fiber retrofit roof assembly to a high performance mineral fiber retrofit wall assembly

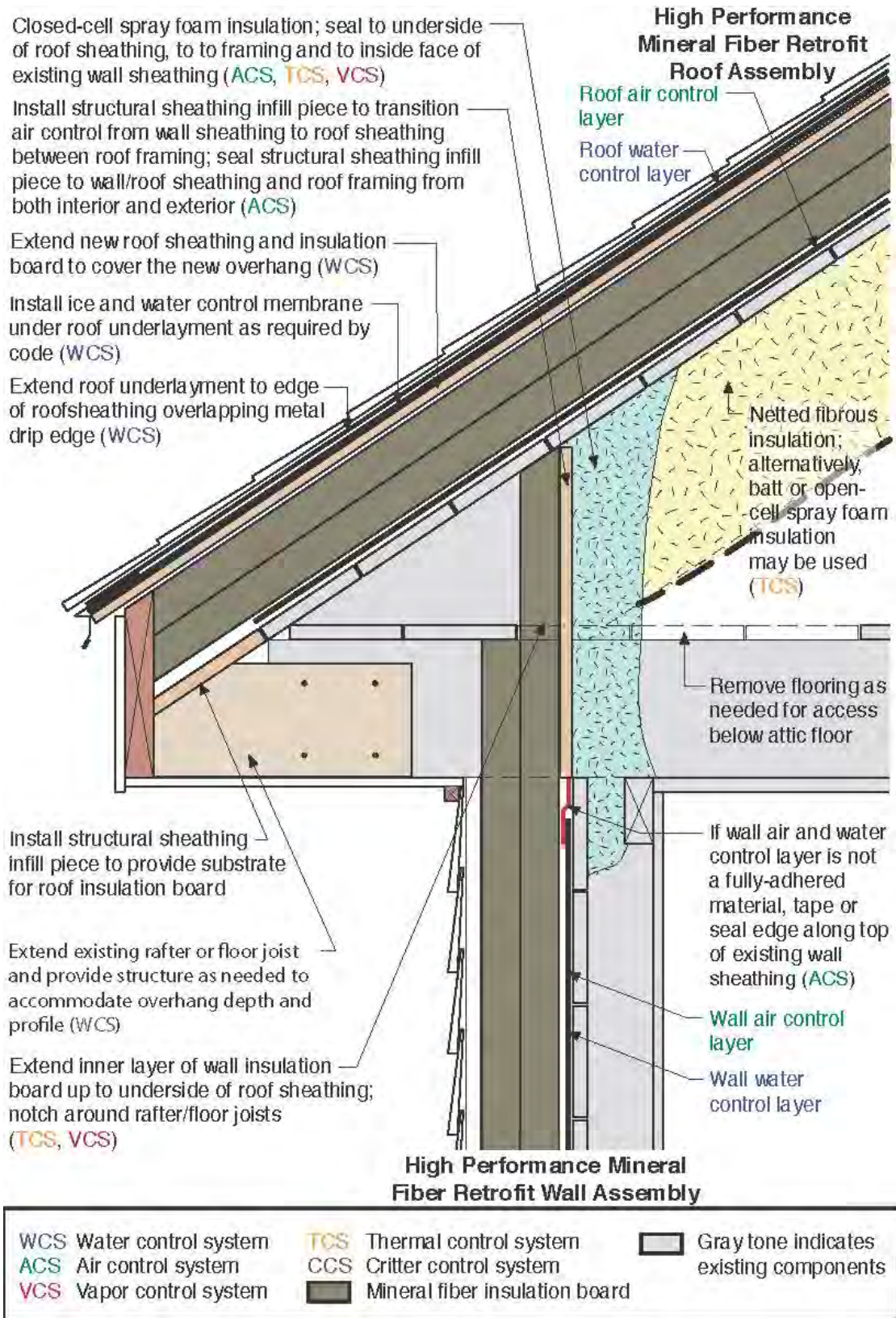
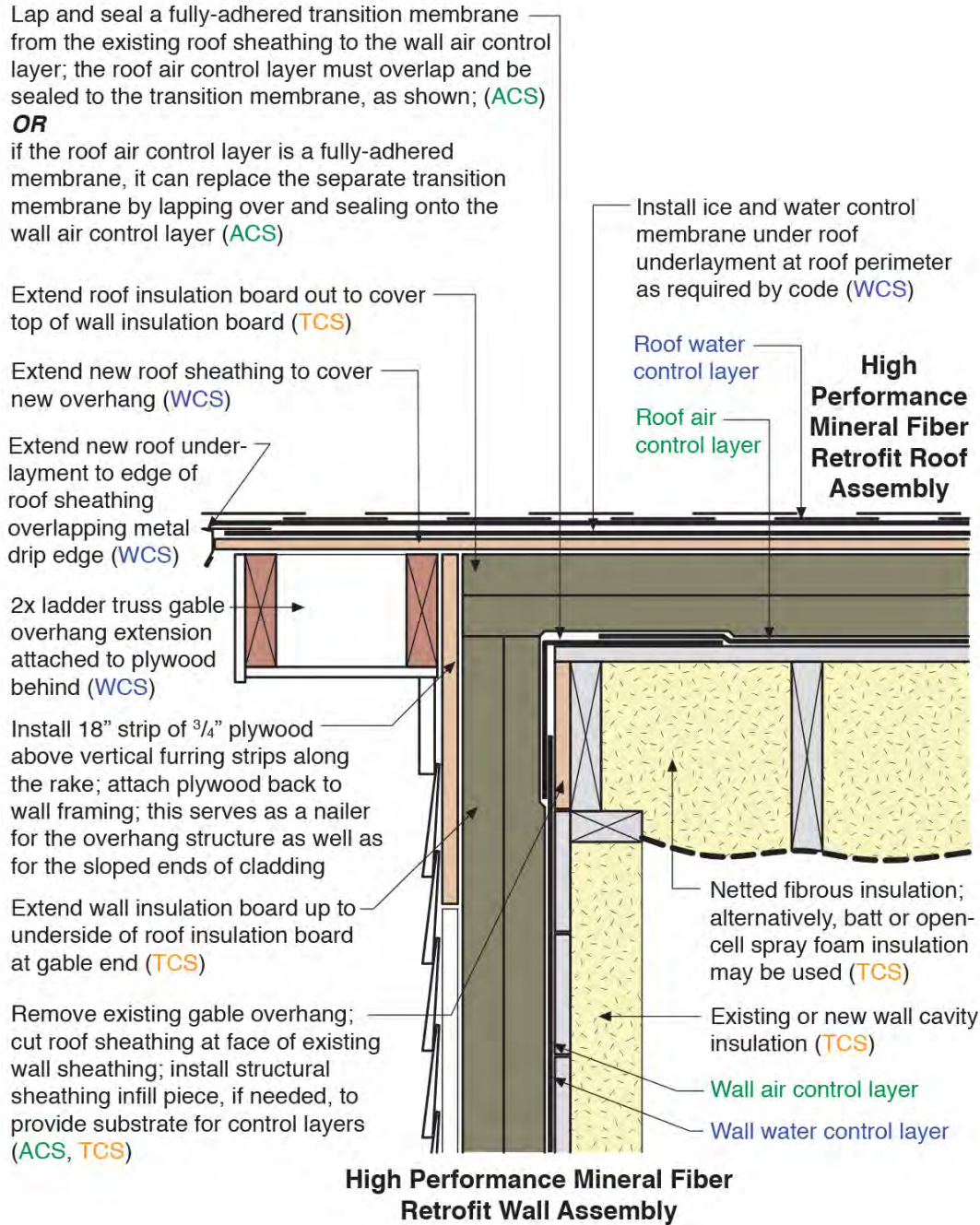
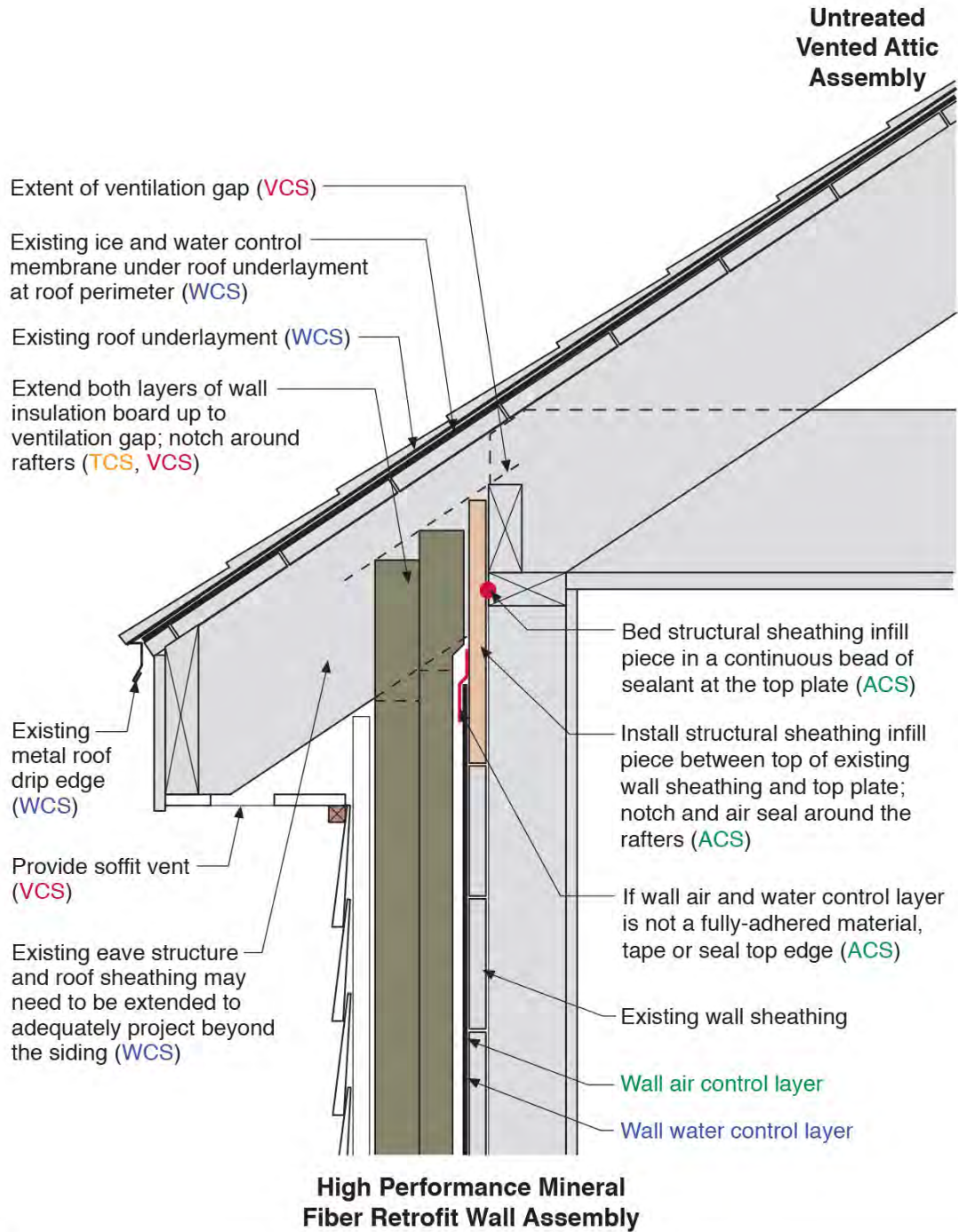

Figure 19. Schematic detail for non-“chainsaw” eave transition from a high performance mineral fiber retrofit roof assembly to a high performance mineral fiber retrofit wall assembly



WCS	Water control system	TCS	Thermal control system	Gray tone	indicates existing components
ACS	Air control system	CCS	Critter control system		
VCS	Vapor control system		Mineral fiber insulation board		

Figure 20. Schematic detail for "chainsaw" gable rake transition from a high performance mineral fiber retrofit roof assembly to a high performance mineral fiber retrofit wall assembly





WCS	Water control system	TCS	Thermal control system		Gray tone indicates existing components
ACS	Air control system	CCS	Critter control system		
VCS	Vapor control system		Mineral fiber insulation board		

Figure 21. Schematic detail for eave transition from a high performance mineral fiber retrofit wall assembly to a non-retrofit roof assembly

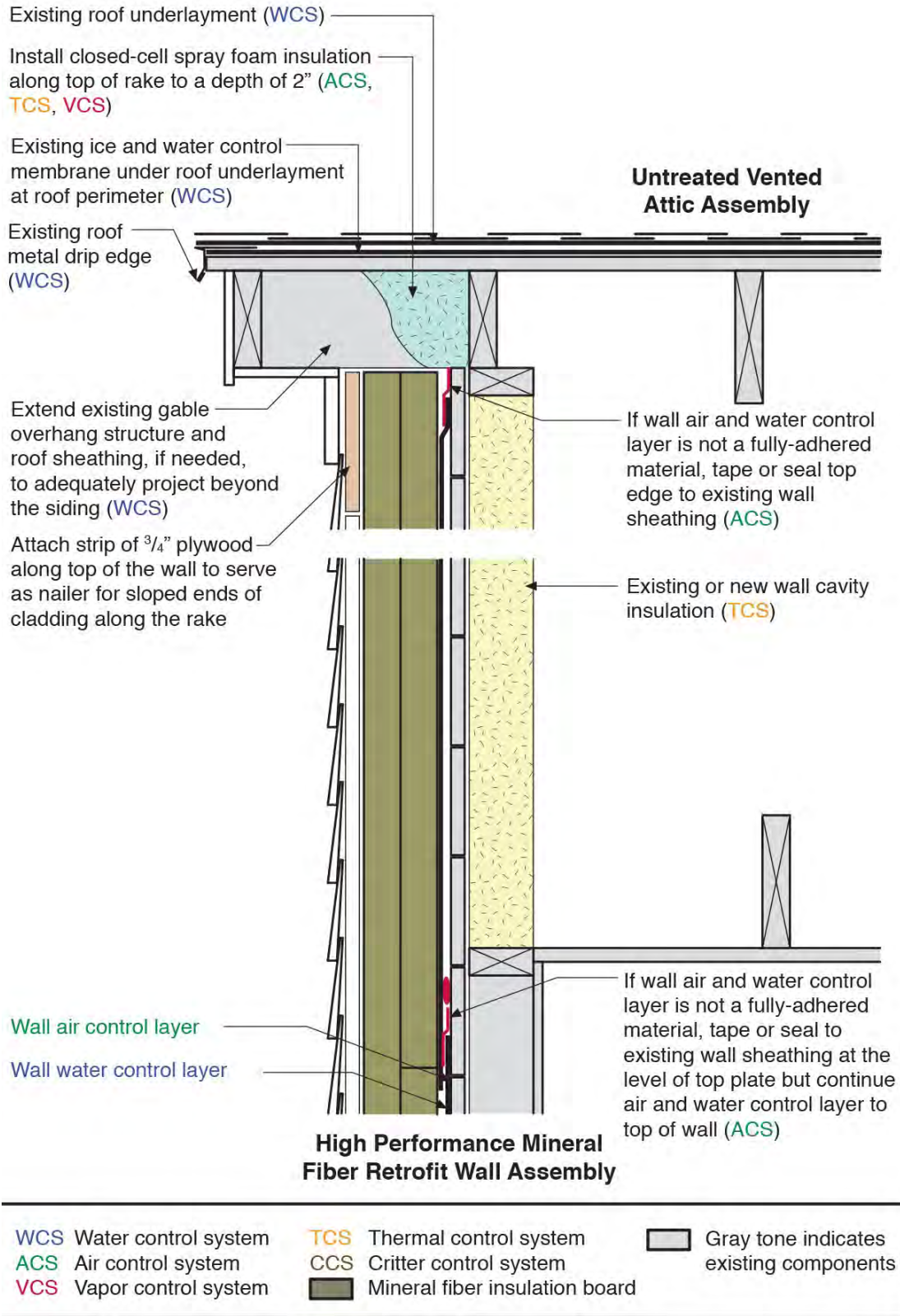
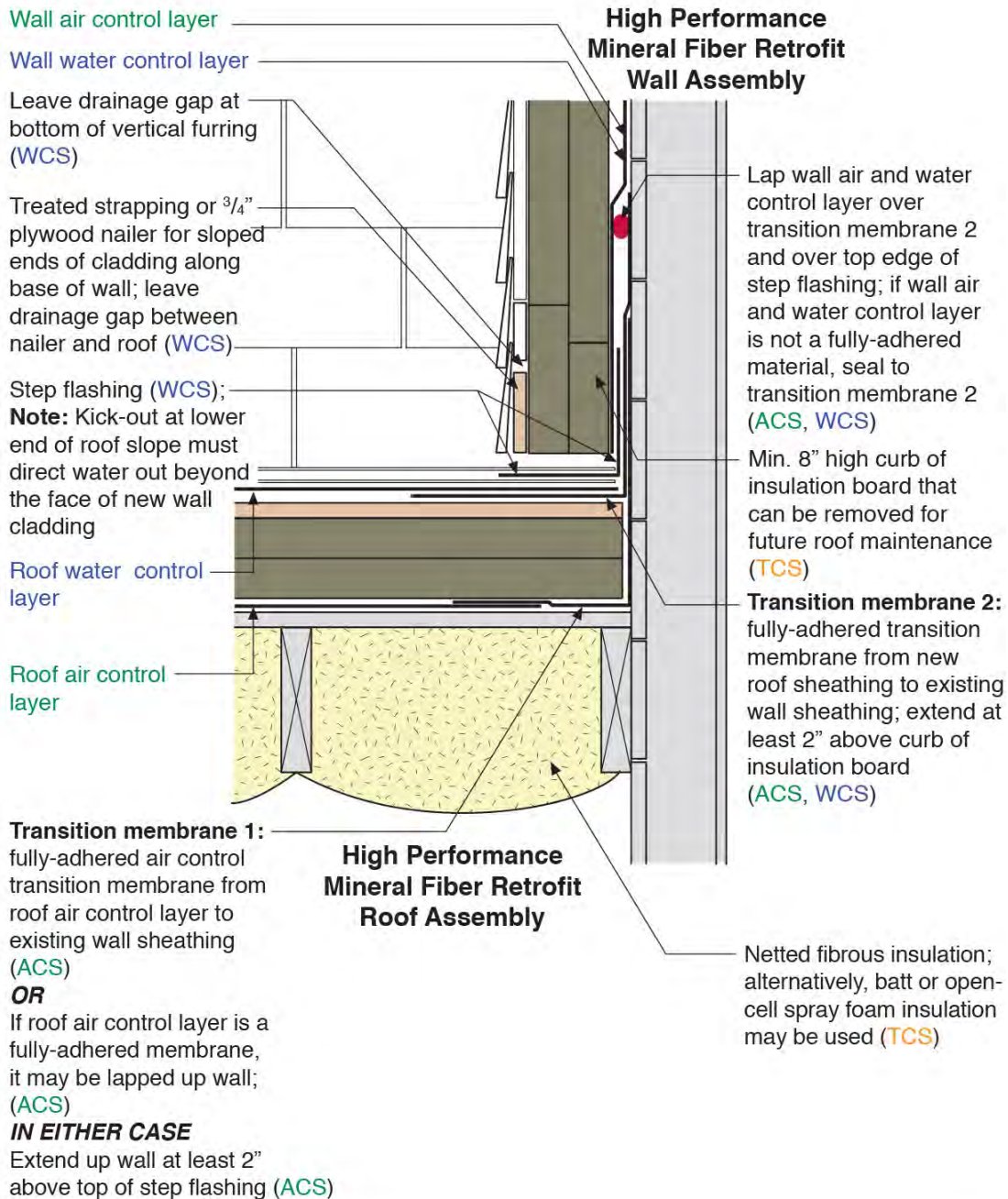
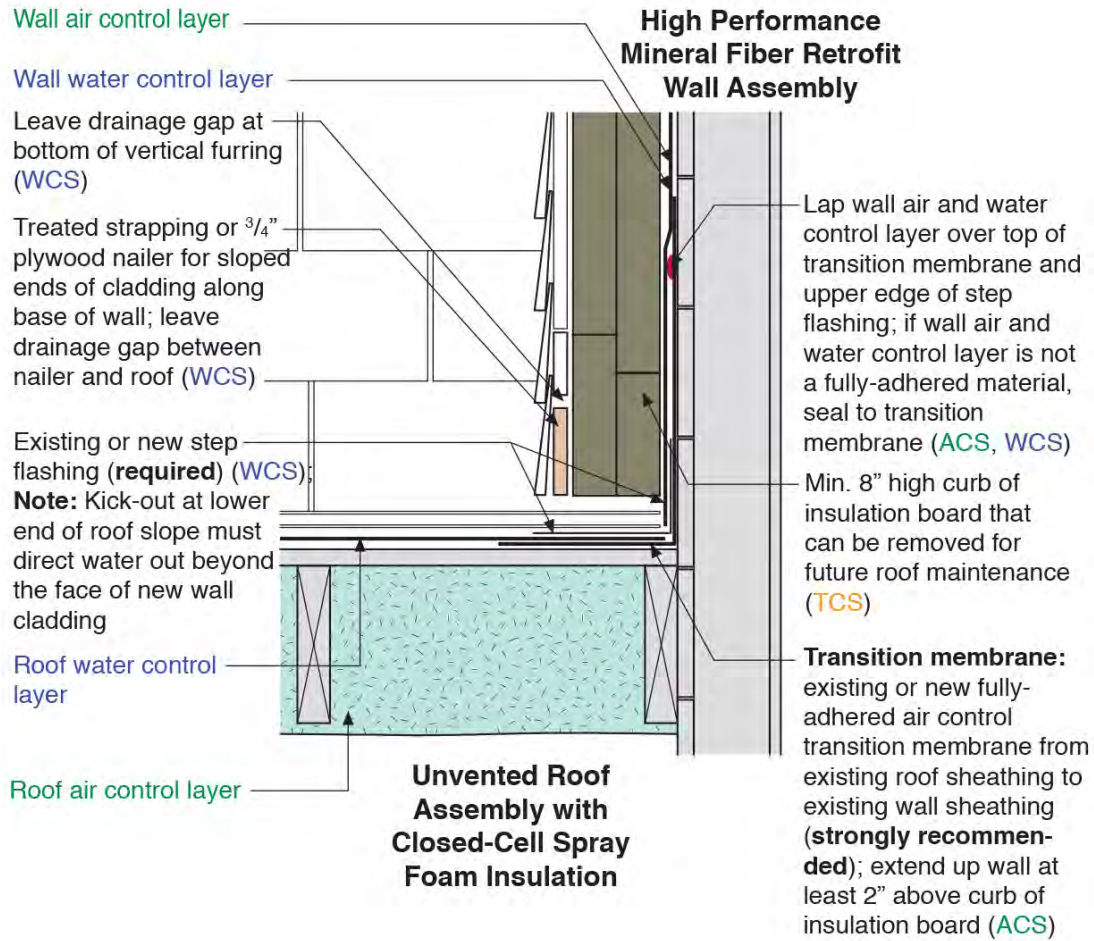

Figure 22. Schematic detail for gable/rake transition from a high performance mineral fiber retrofit wall assembly to a non-retrofit roof assembly



WCS	Water control system	TCS	Thermal control system	Gray tone	indicates existing components
ACS	Air control system	CCS	Critter control system		
VCS	Vapor control system		Mineral fiber insulation board		

Figure 23. Schematic detail for transition from a lower high performance mineral fiber retrofit roof assembly to a high performance mineral fiber retrofit wall assembly



WCS	Water control system	TCS	Thermal control system	Gray tone	indicates existing components
ACS	Air control system	CCS	Critter control system		
VCS	Vapor control system		Mineral fiber insulation board		

Figure 24. Schematic detail for transition from a high performance mineral fiber retrofit wall assembly to an insulated lower roof assembly

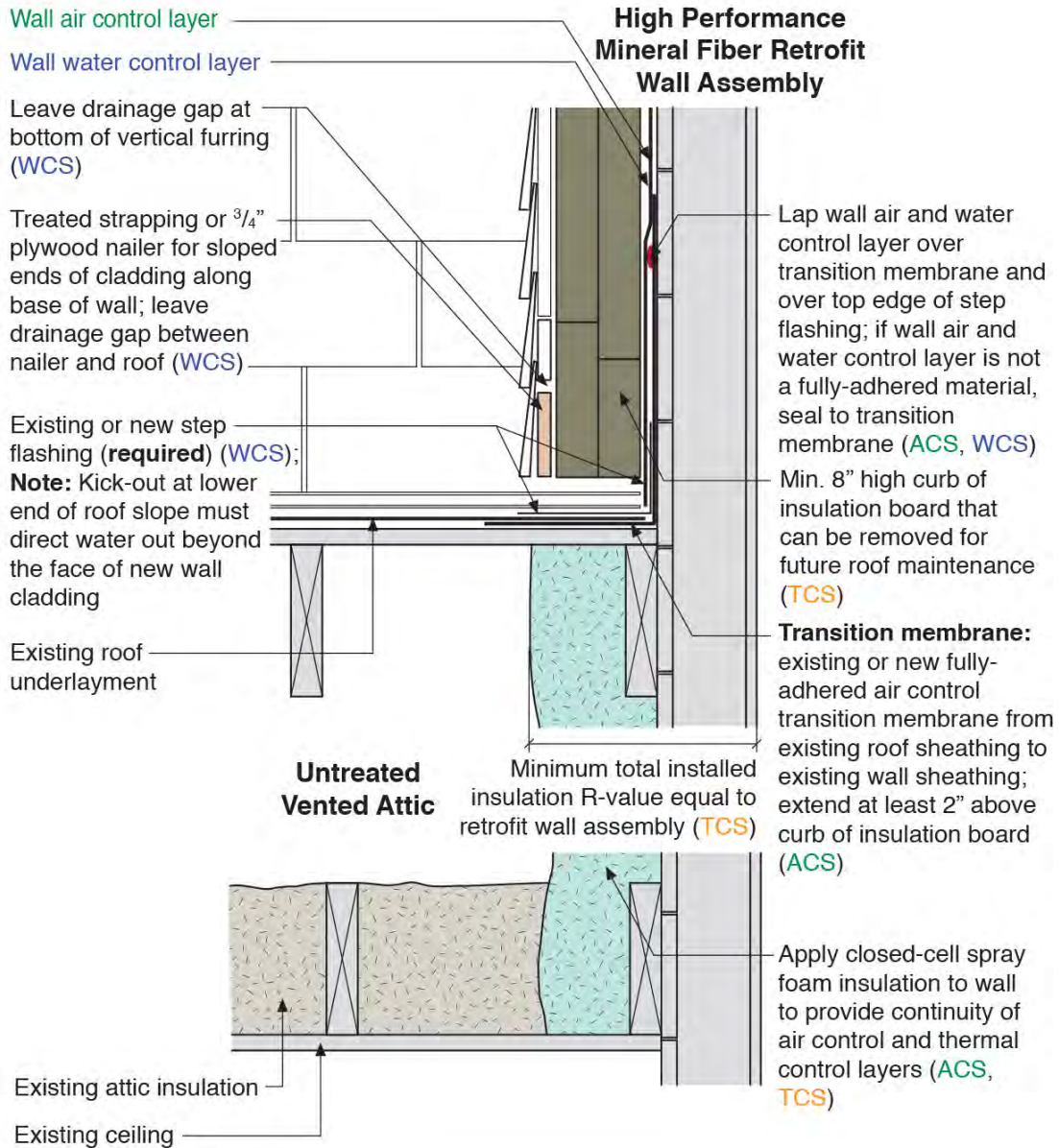



WCS	Water control system	TCS	Thermal control system		Gray tone indicates existing components
ACS	Air control system	CCS	Crittter control system		Mineral fiber insulation board
VCS	Vapor control system				

Figure 25. Schematic detail for transition from a high performance mineral fiber retrofit wall assembly to an existing lower attic

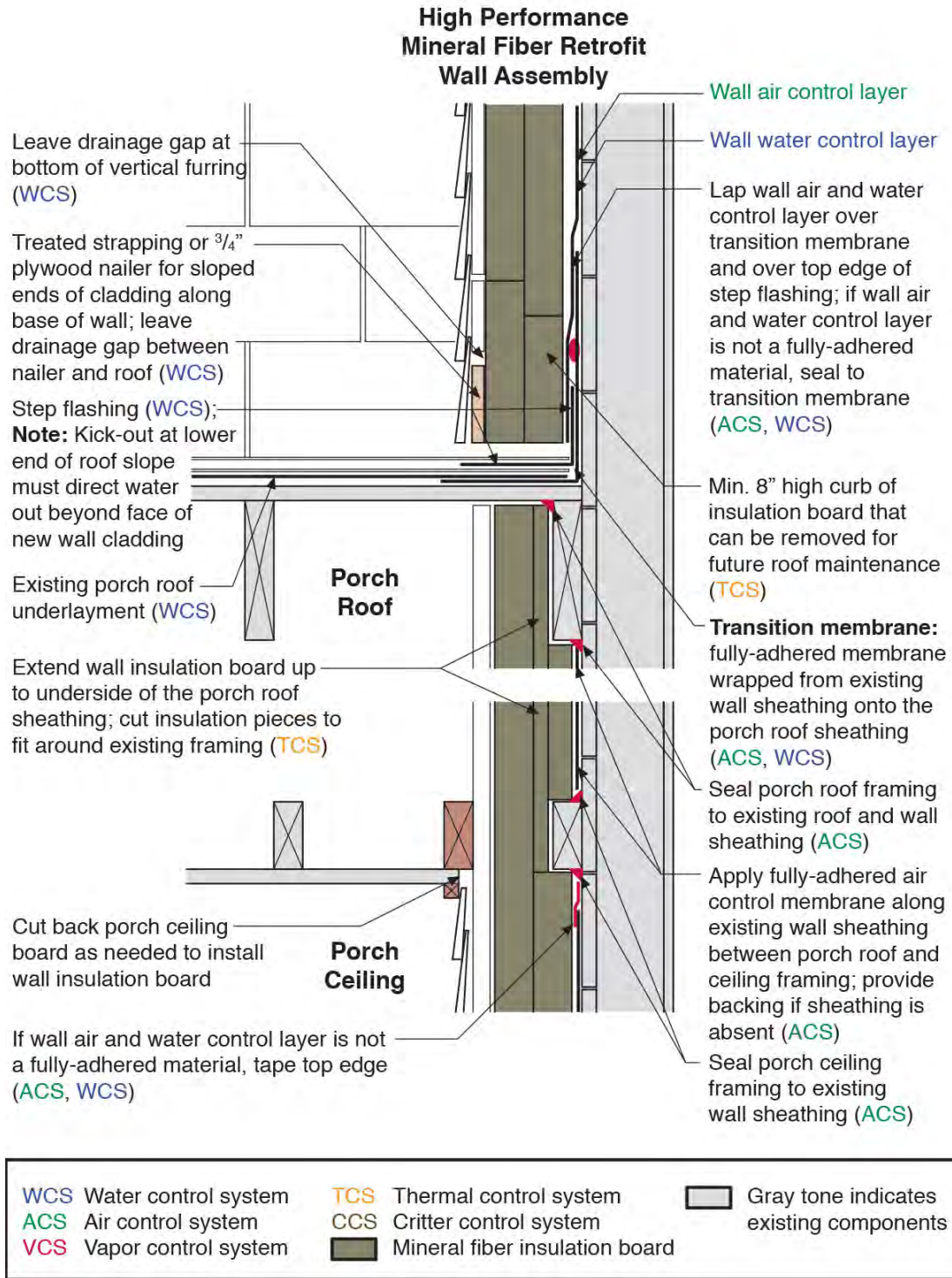

Figure 26. Schematic detail for transition from a high performance mineral fiber retrofit wall assembly to a porch roof

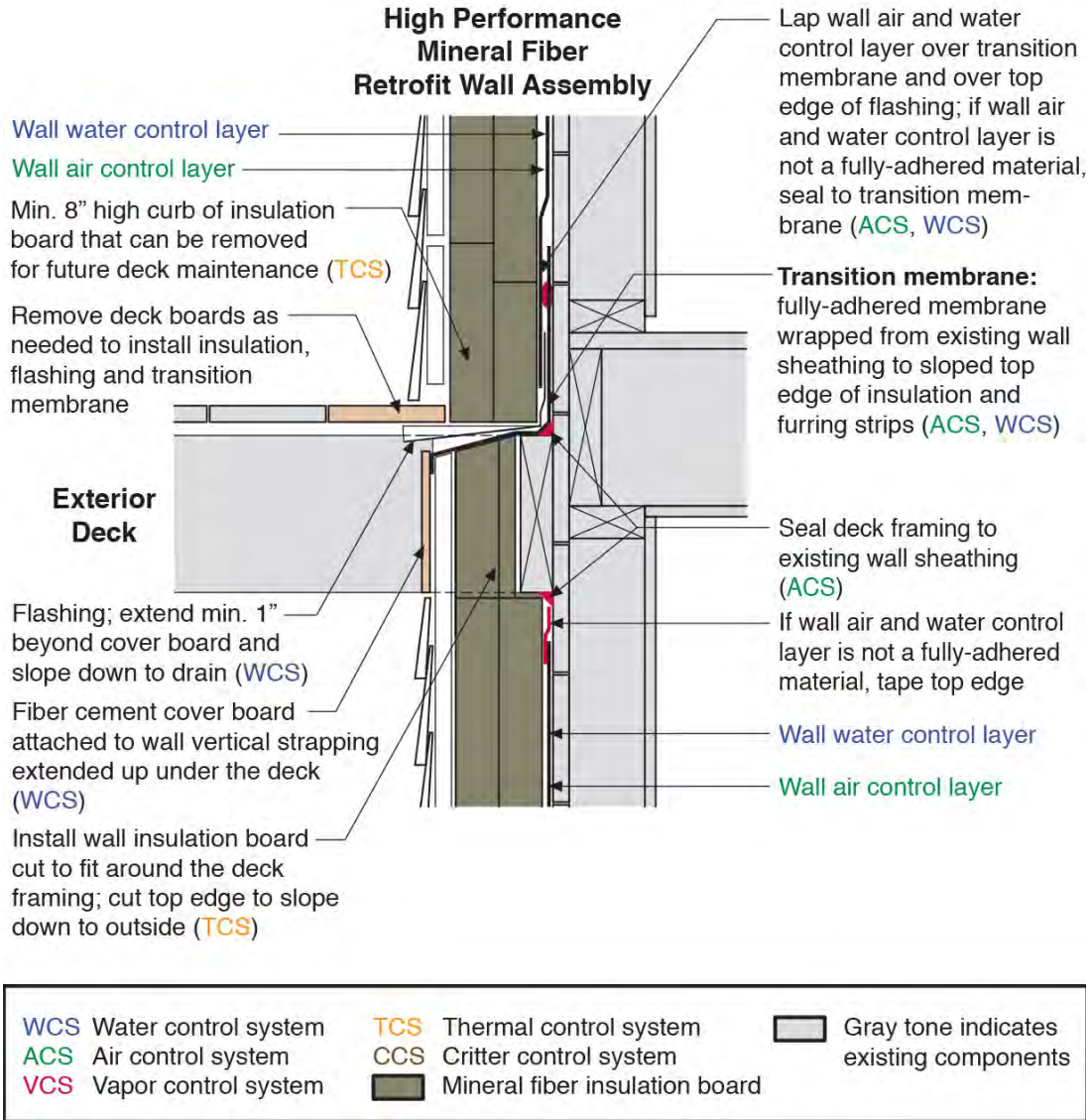
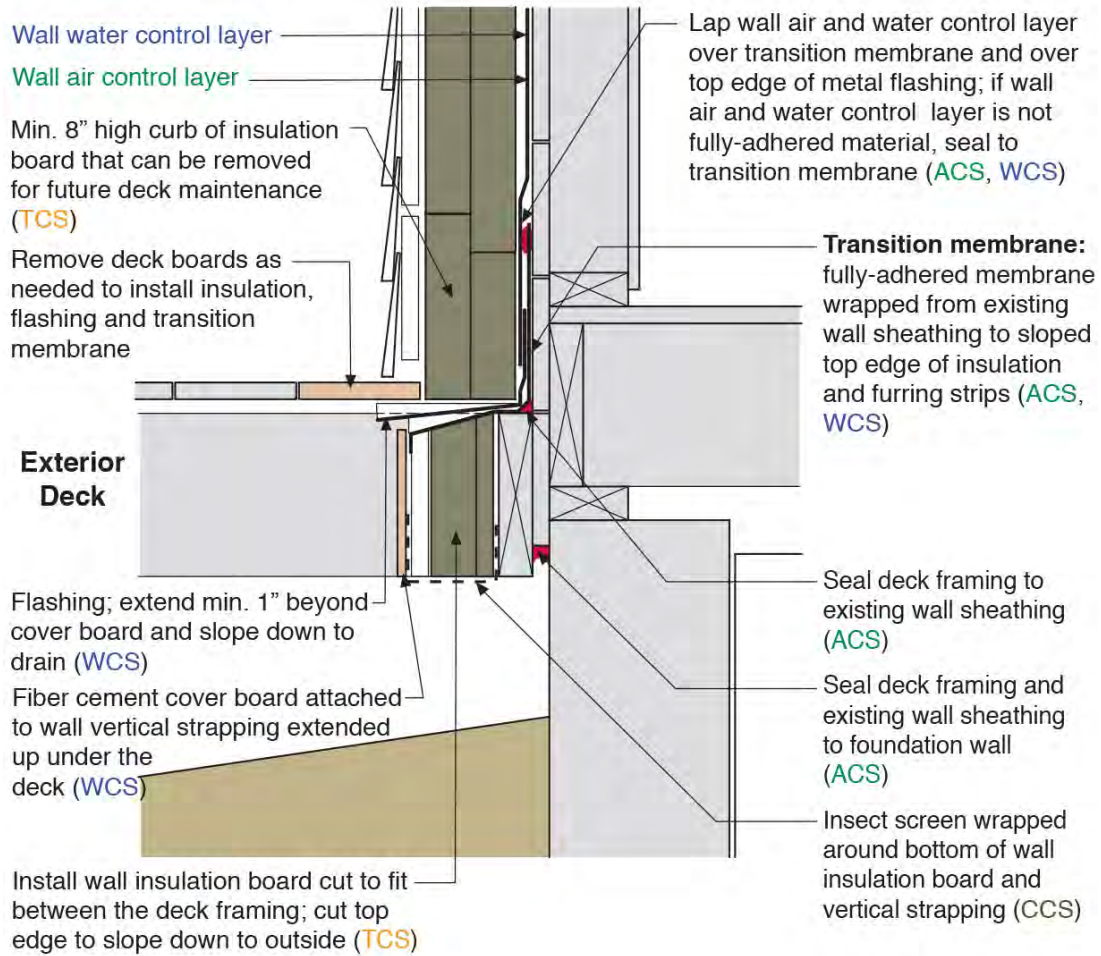

Figure 27. Schematic detail for transition from a high performance mineral fiber retrofit wall assembly to an attached deck in a field of wall

High Performance Mineral Fiber Retrofit Wall Assembly





WCS	Water control system	TCS	Thermal control system		Gray tone indicates existing components
ACS	Air control system	CCS	Critter control system		Mineral fiber insulation board
VCS	Vapor control system				

Figure 28. Schematic detail for transition from a high performance mineral fiber retrofit wall assembly to an attached deck at base of wall

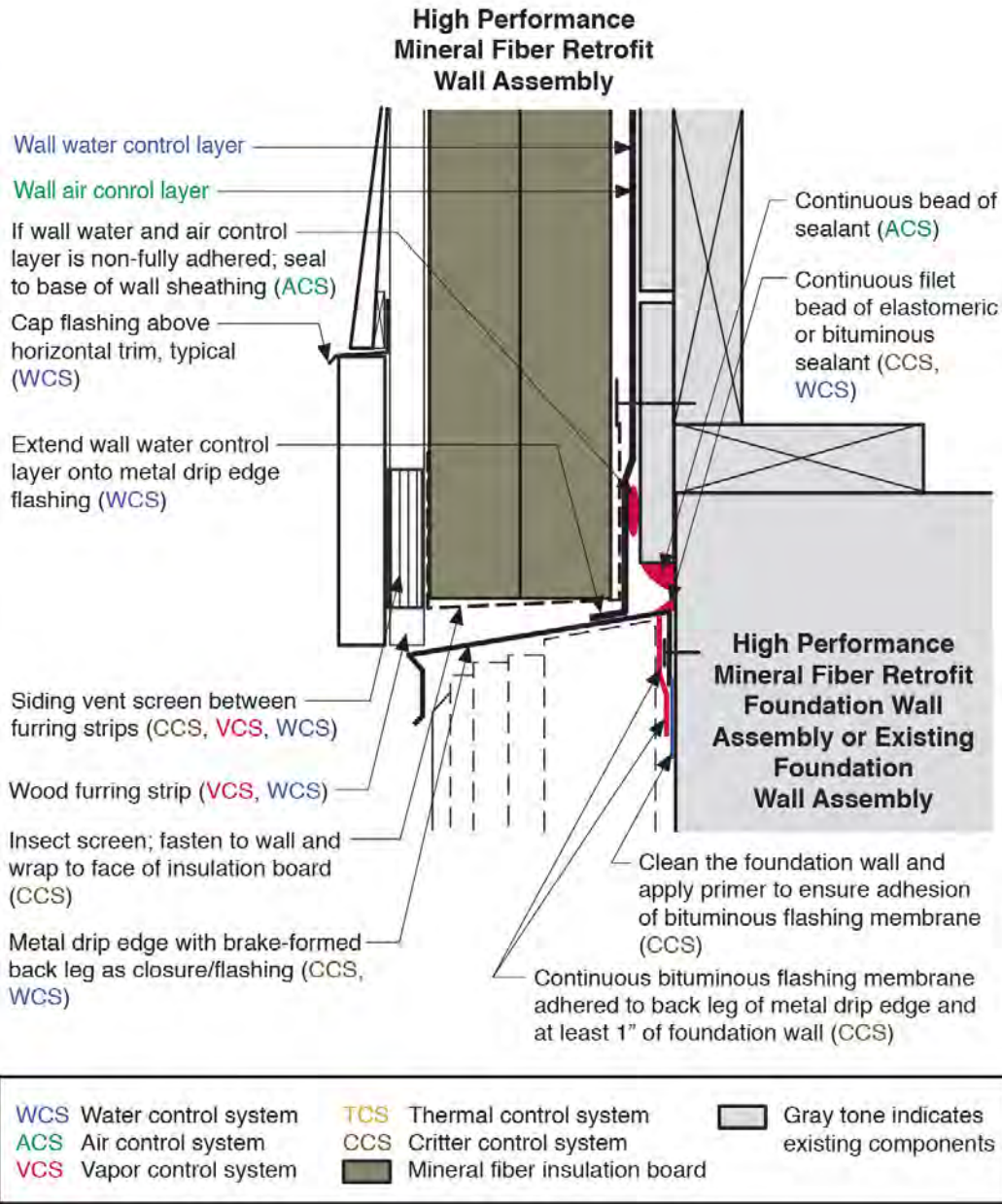

Figure 29. Schematic detail for transition from a high performance mineral fiber retrofit wall assembly to a top of high performance mineral fiber retrofit foundation wall assembly

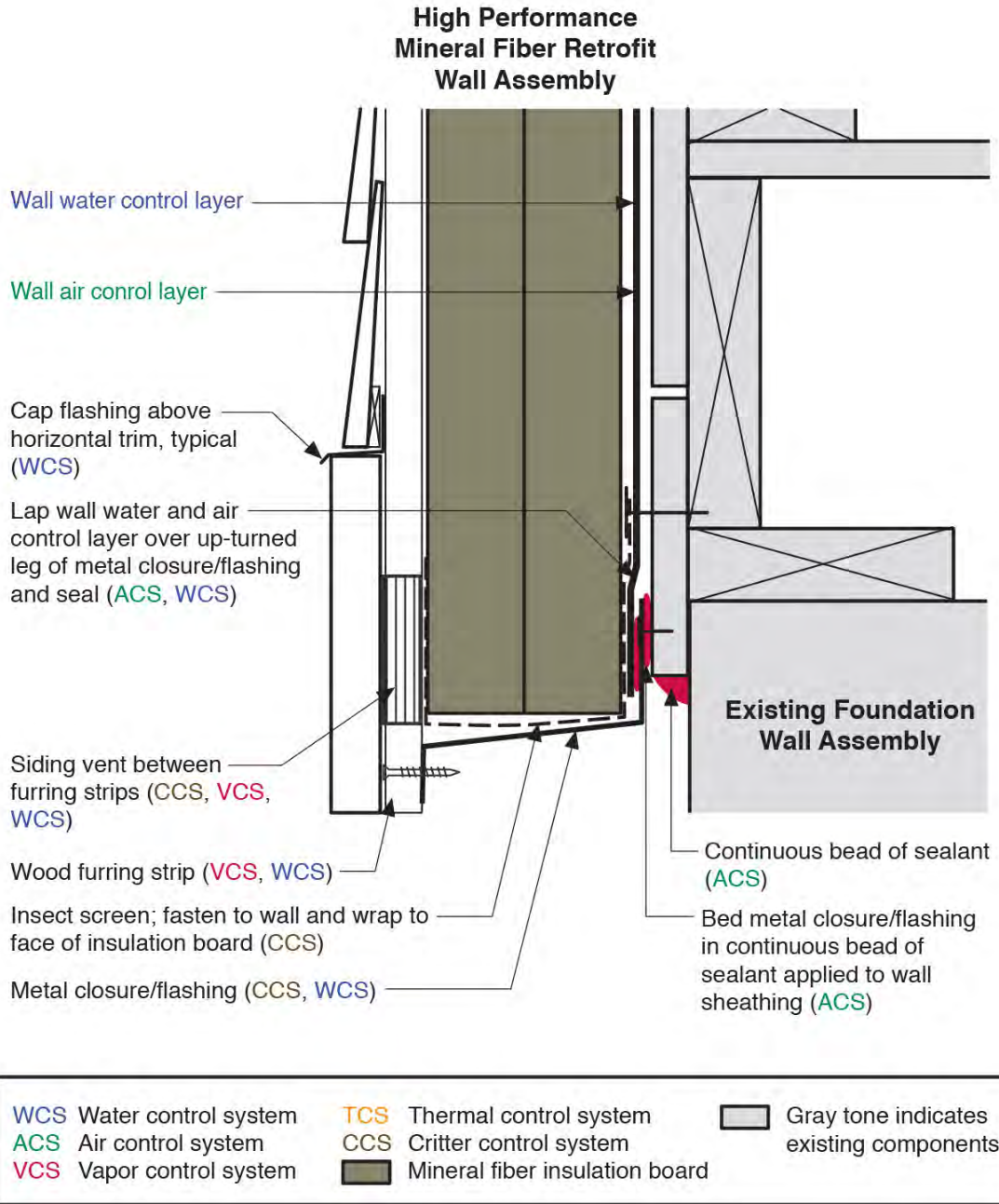

Figure 30. Schematic detail for transition from a high performance mineral fiber retrofit wall assembly to a flat-surface foundation wall without exterior retrofit

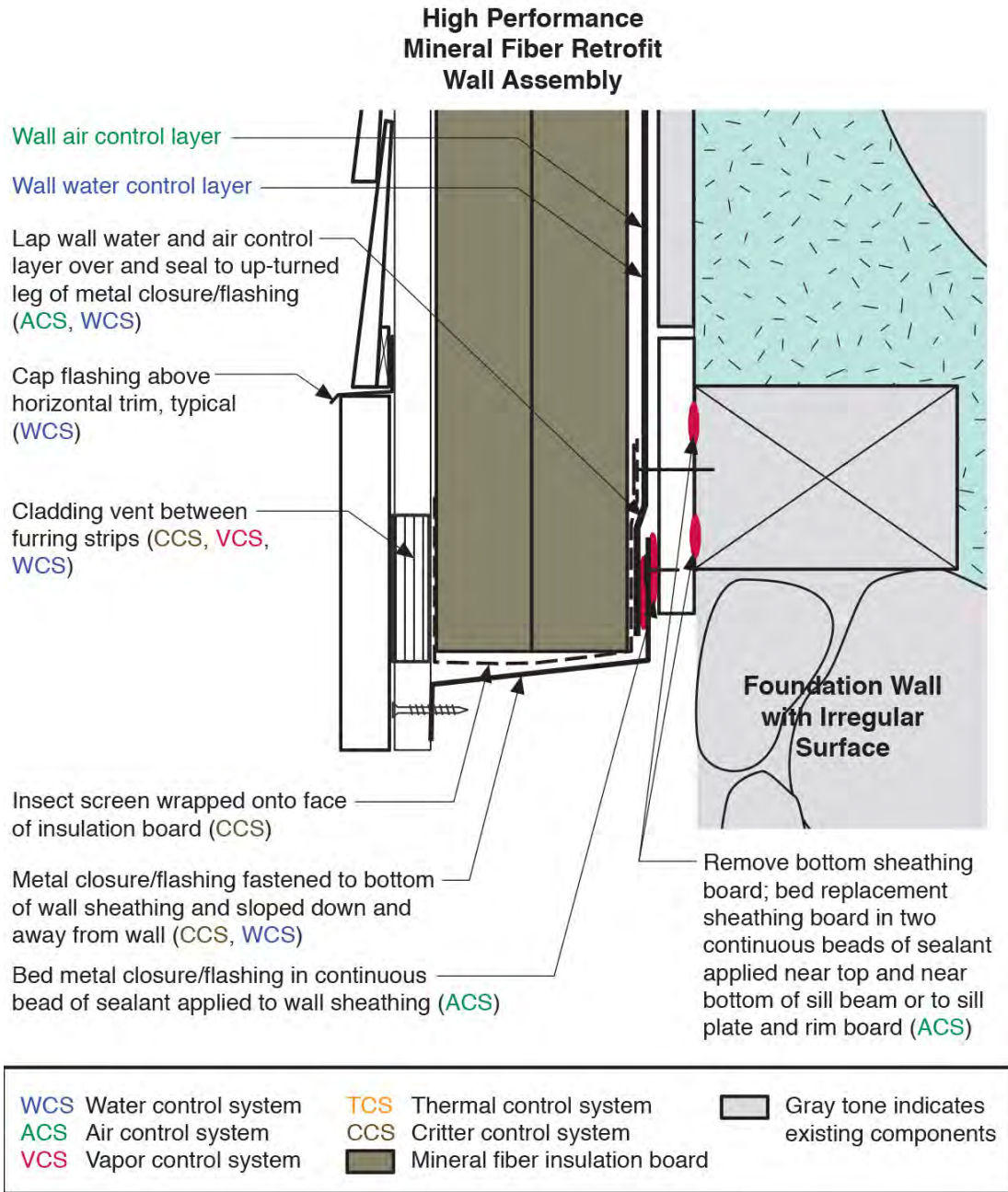

Figure 31. Schematic detail for transition from a high performance mineral fiber retrofit wall assembly to a bumpy-surface foundation wall

Figure 32 through Figure 43 show the installation of a new window or the reinstallation of a window in the high performance mineral fiber retrofit wall assembly. The schematic details include schematics for the head, jamb, and sill of the window opening. The sequence illustrations demonstrate (1) installation of a window in a wall assembly using a non-adhered sheet good water and air control membrane; and (2) installation of the exterior trim extension. The window installation sequence for a fully adhered or liquid-applied water and air control membrane is slightly different in how the head flashing is integrated into the water and air control membrane.

The trim installation sequence is applicable to situations where the existing window is left in place.

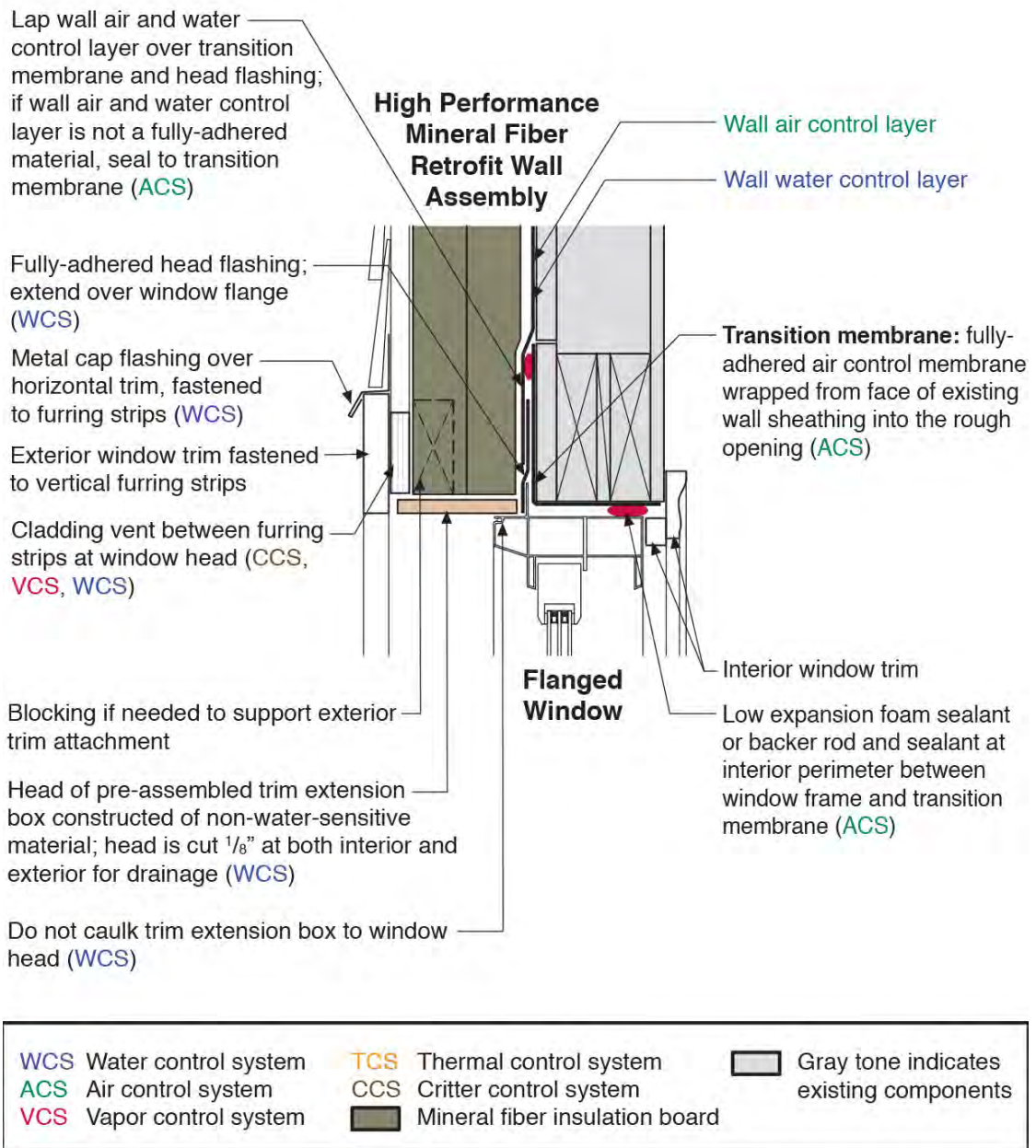

Figure 32. Schematic detail for window head of new window or reinstalled window in a high performance mineral fiber retrofit wall assembly

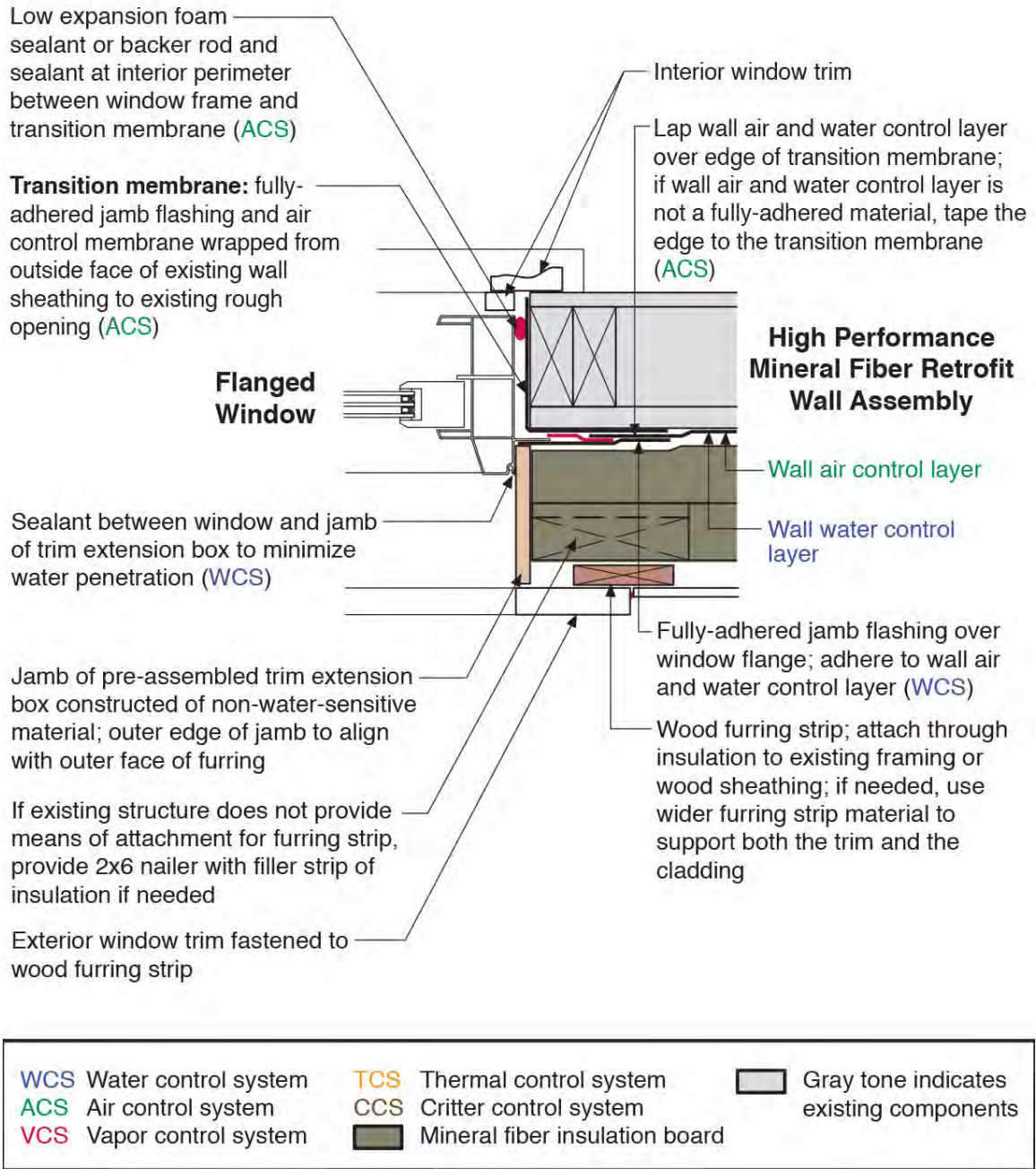
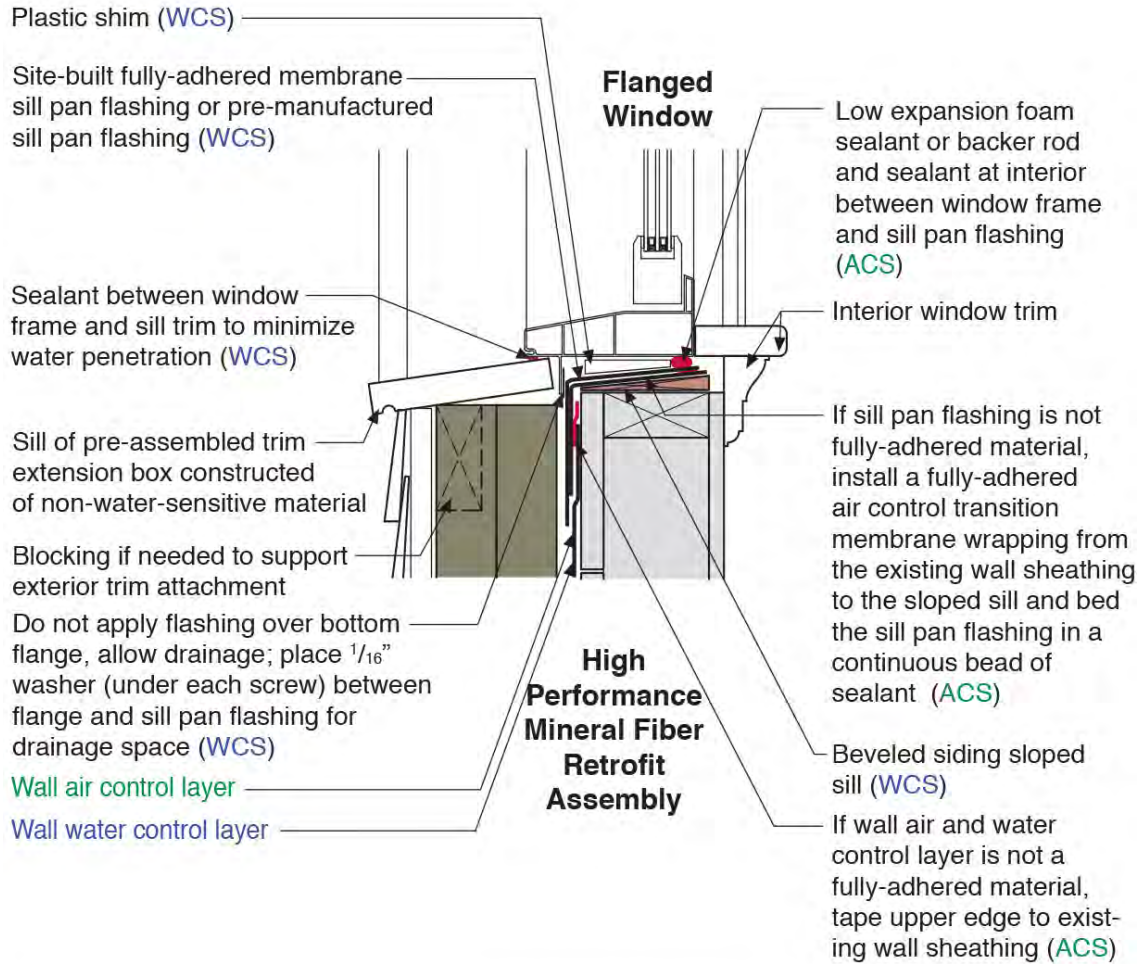

Figure 33. Schematic detail for window jamb of new window or reinstalled window in a high performance mineral fiber retrofit wall assembly





WCS Water control system	TCS Thermal control system	 Gray tone indicates existing components
ACS Air control system	CCS Critter control system	
VCS Vapor control system	 Mineral fiber insulation board	

Figure 34. Schematic detail for window sill of new window or reinstalled window in a high performance mineral fiber retrofit wall assembly

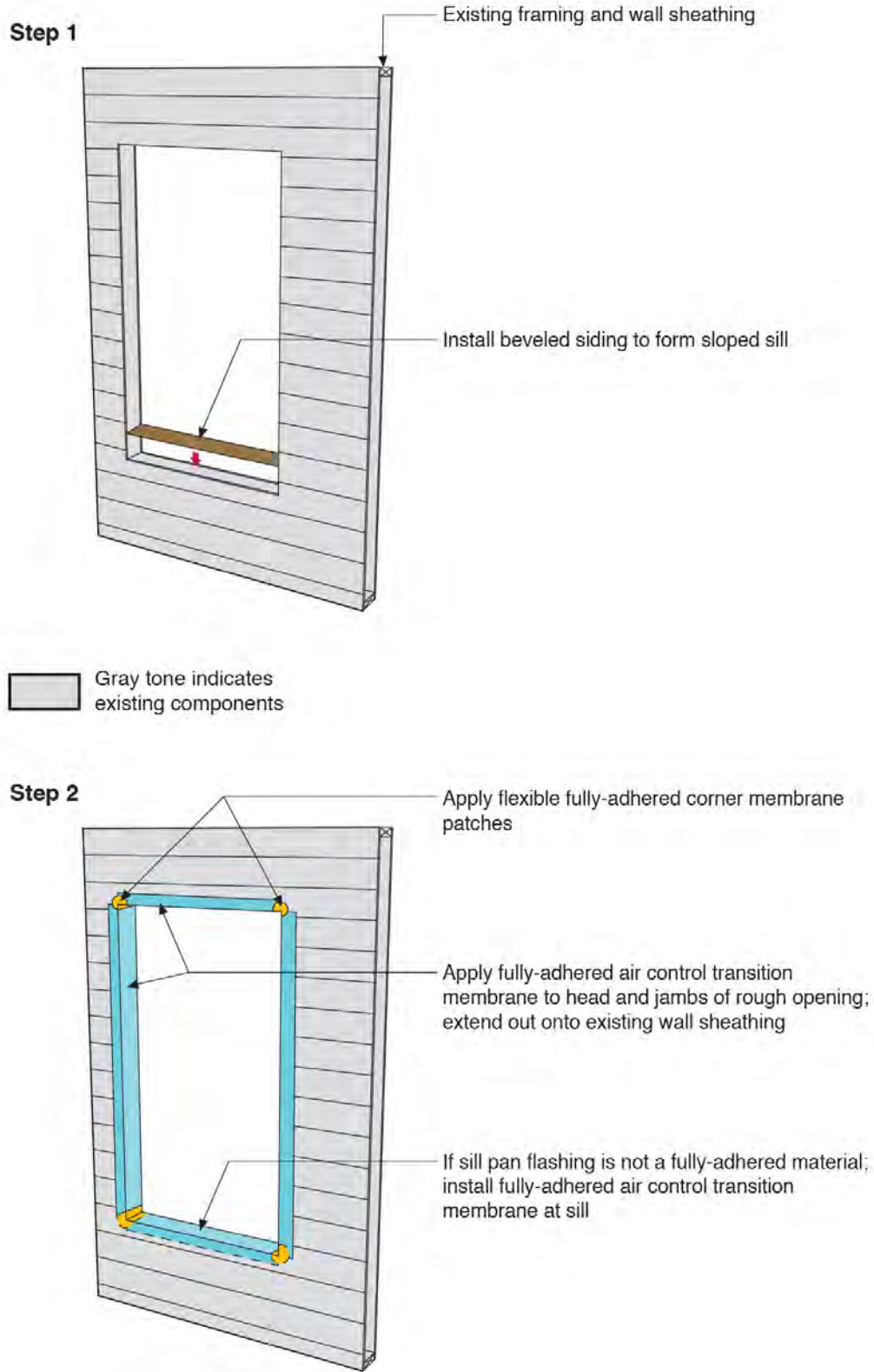
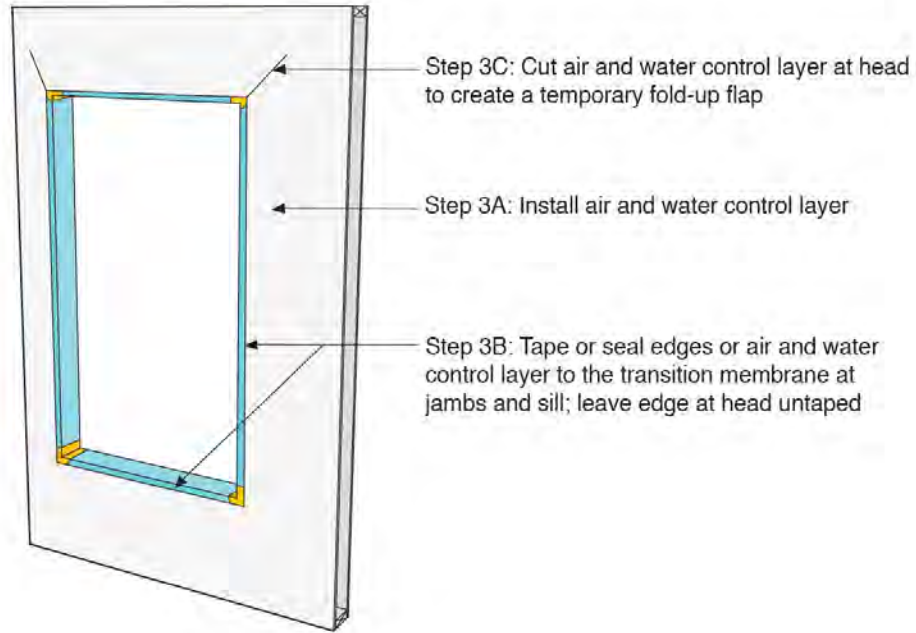



Figure 35. Steps 1 and 2 of installation sequence for new window or reinstalled window in a high performance mineral fiber retrofit wall assembly

Step 3



 Gray tone indicates existing components

Step 4

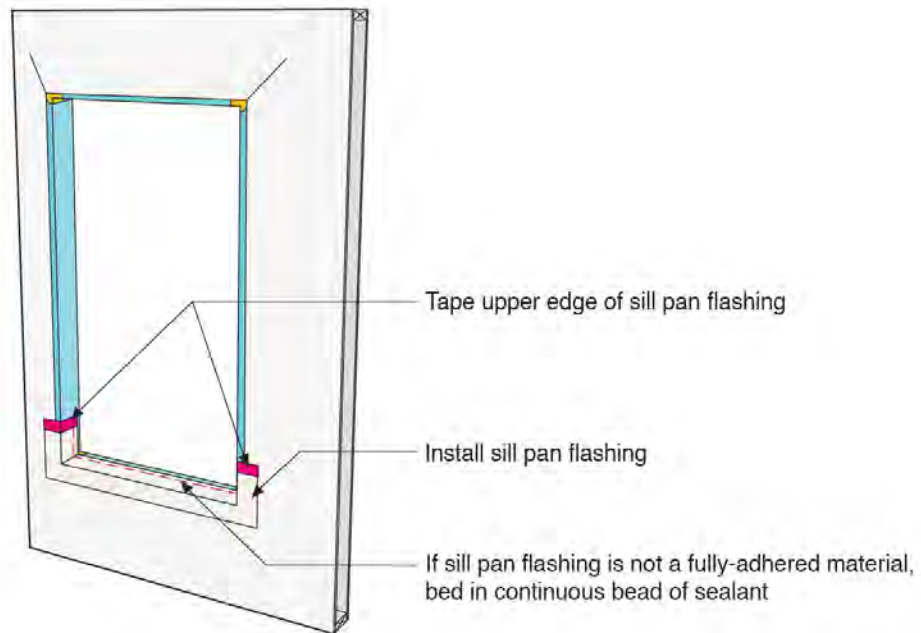
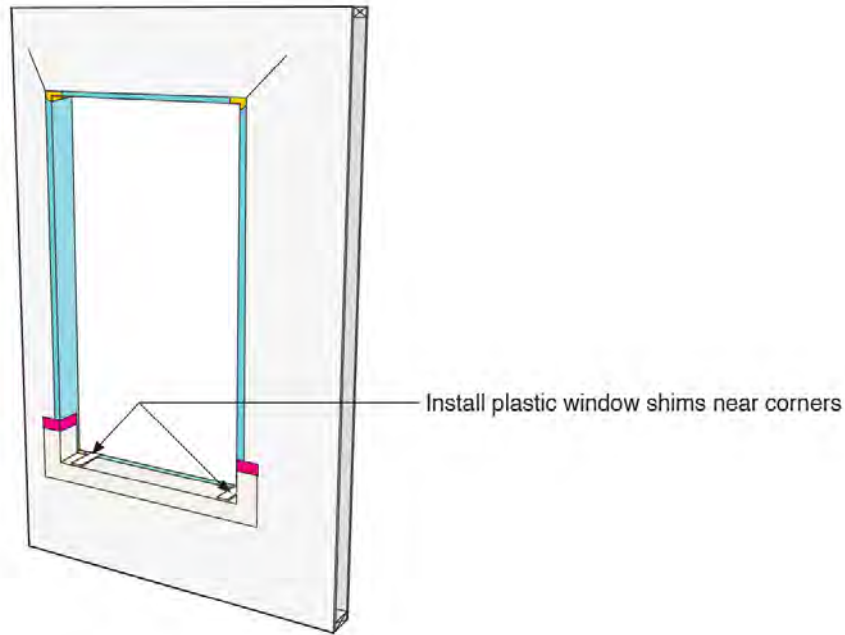

Figure 36. Steps 3 and 4 of installation sequence for new window or reinstalled window in a high performance mineral fiber retrofit wall assembly

Step 5



Step 6

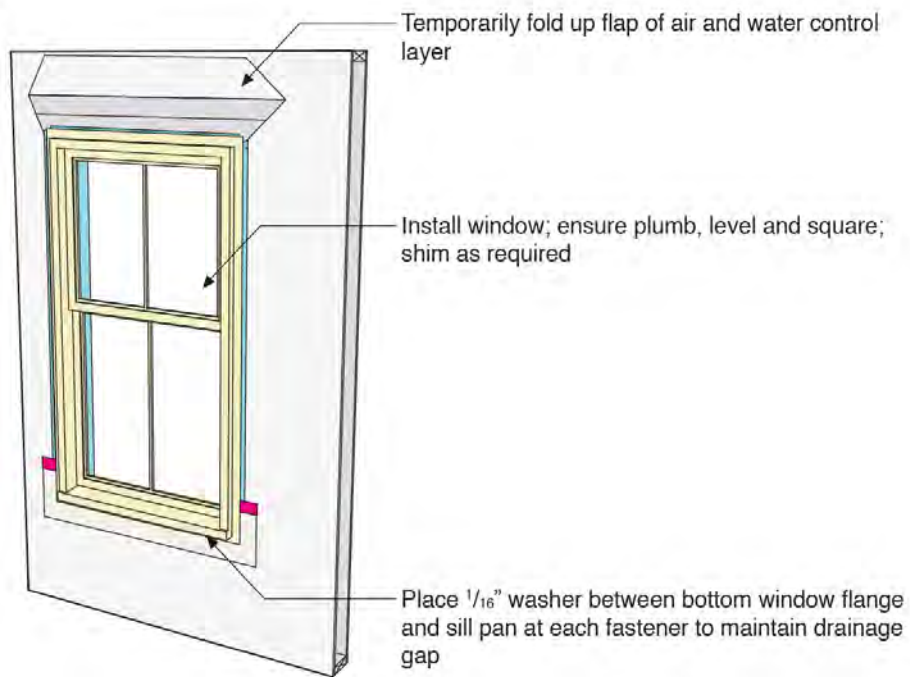



Figure 37. Steps 5 and 6 of installation sequence for new window or reinstalled window in a high performance mineral fiber retrofit wall assembly

Step 7



Install fully-adhered jamb flashing over window flange

 Gray tone indicates existing components

Step 8

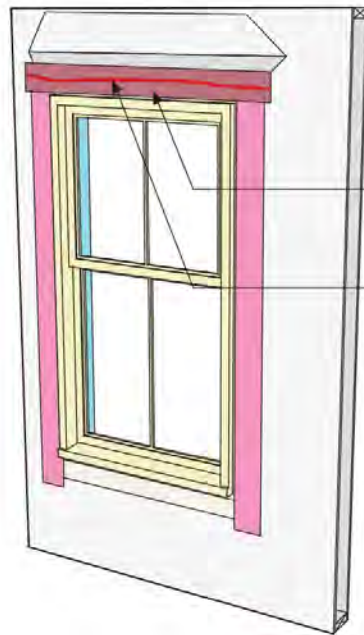

Install fully-adhered head flashing over window flange and extend over top of jamb flashing

If wall air and water control layer is not a fully-adhered material, apply a continuous bead of sealant across the head flashing to seal the wall air and water control membrane to the head flashing

Figure 38. Steps 7 and 8 of installation sequence for new window or reinstalled window in a high performance mineral fiber retrofit wall assembly

Step 9

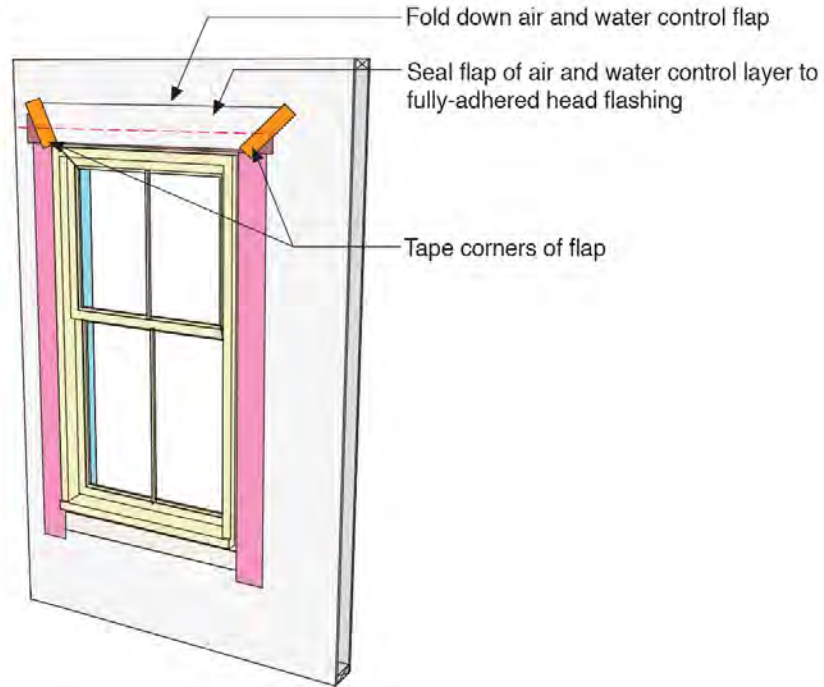

Gray tone indicates existing components

Step 10

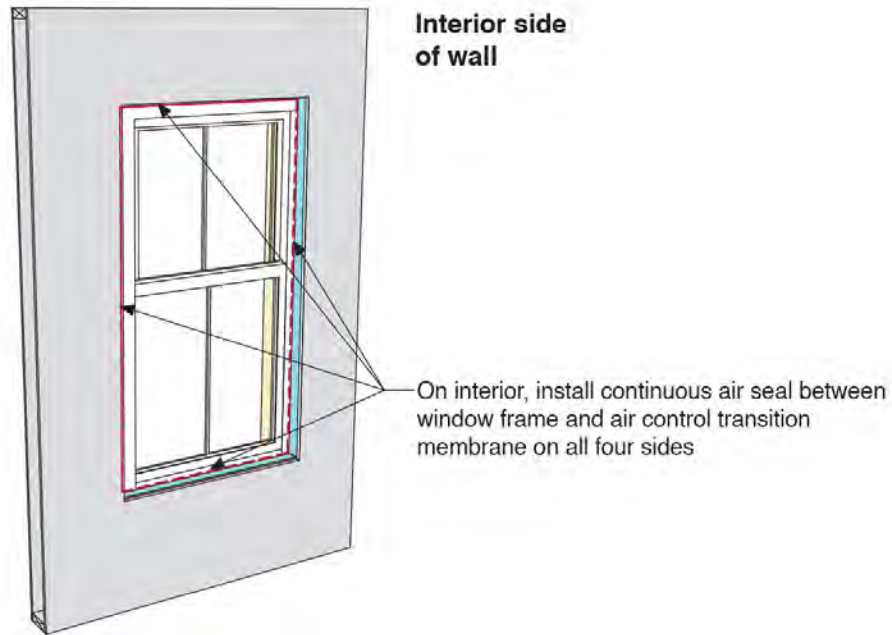
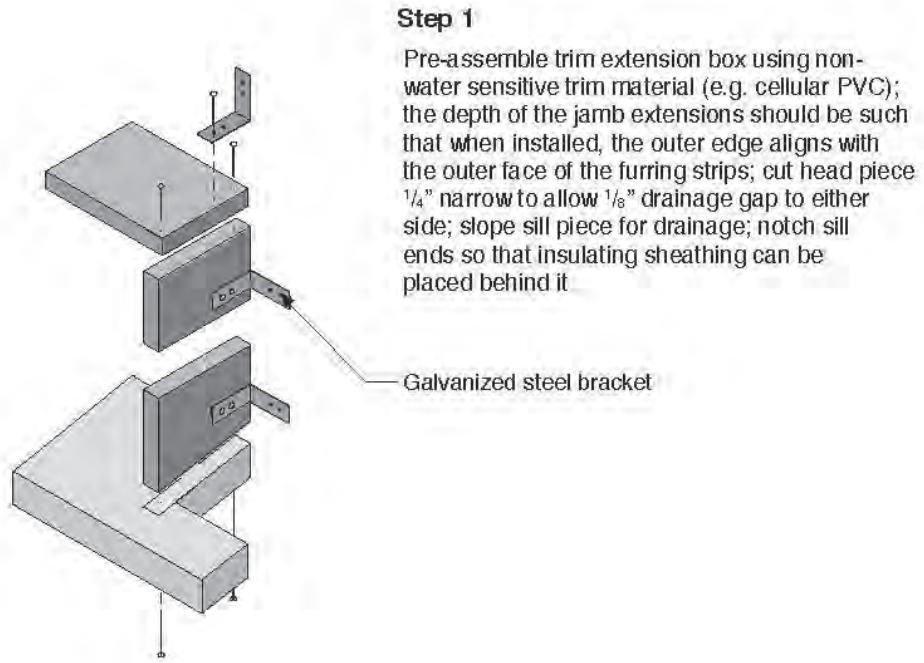



Figure 39. Steps 9 and 10 of installation sequence for new window or reinstalled window in a high performance mineral fiber retrofit wall assembly



 Tan tone indicates existing components

Step 2

Attach trim extension box after window is installed and integrated into air and water control layer

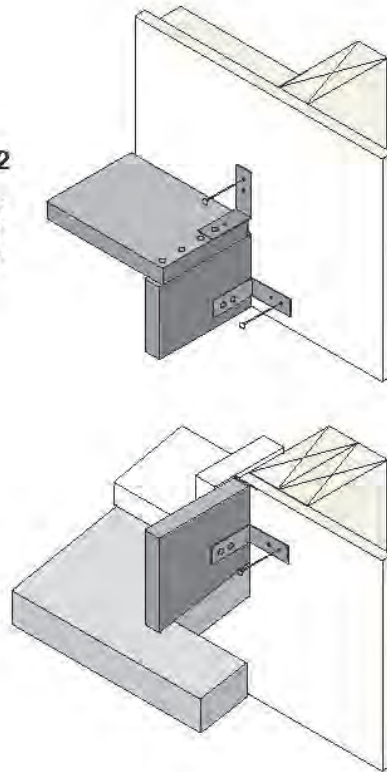
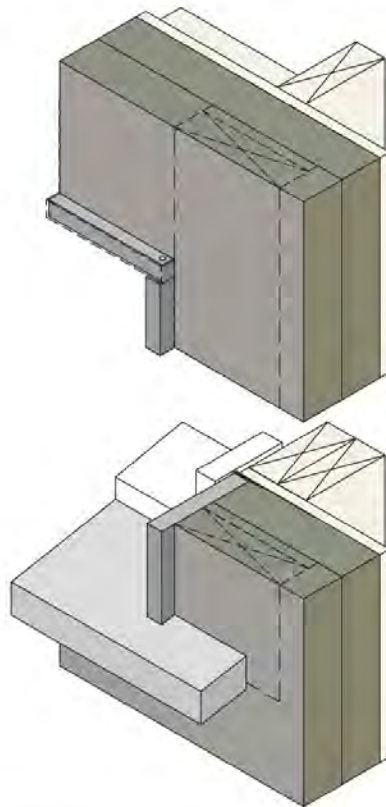



Figure 40. Steps 1 and 2 of exterior trim installation sequence for window in a high performance mineral fiber retrofit wall assembly

Step 3

Install insulating sheathing up tight to the trim extension box; if optional nailer is needed, install in the plane of the outer layer of insulating sheathing.



 Tan tone indicates existing structure

Step 4

Install furring in vertical orientation only to support window trim and cladding; leave space for drainage between the furring and the trim extension box; install cladding vent between furring strips at window head.

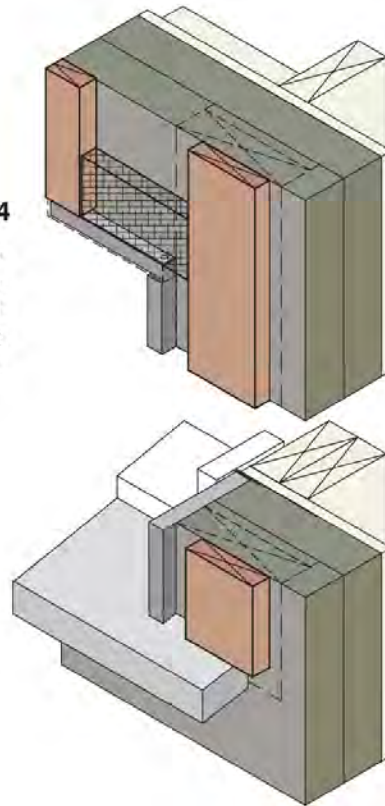

Figure 41. Steps 3 and 4 of exterior trim installation sequence for window in a high performance mineral fiber retrofit wall assembly

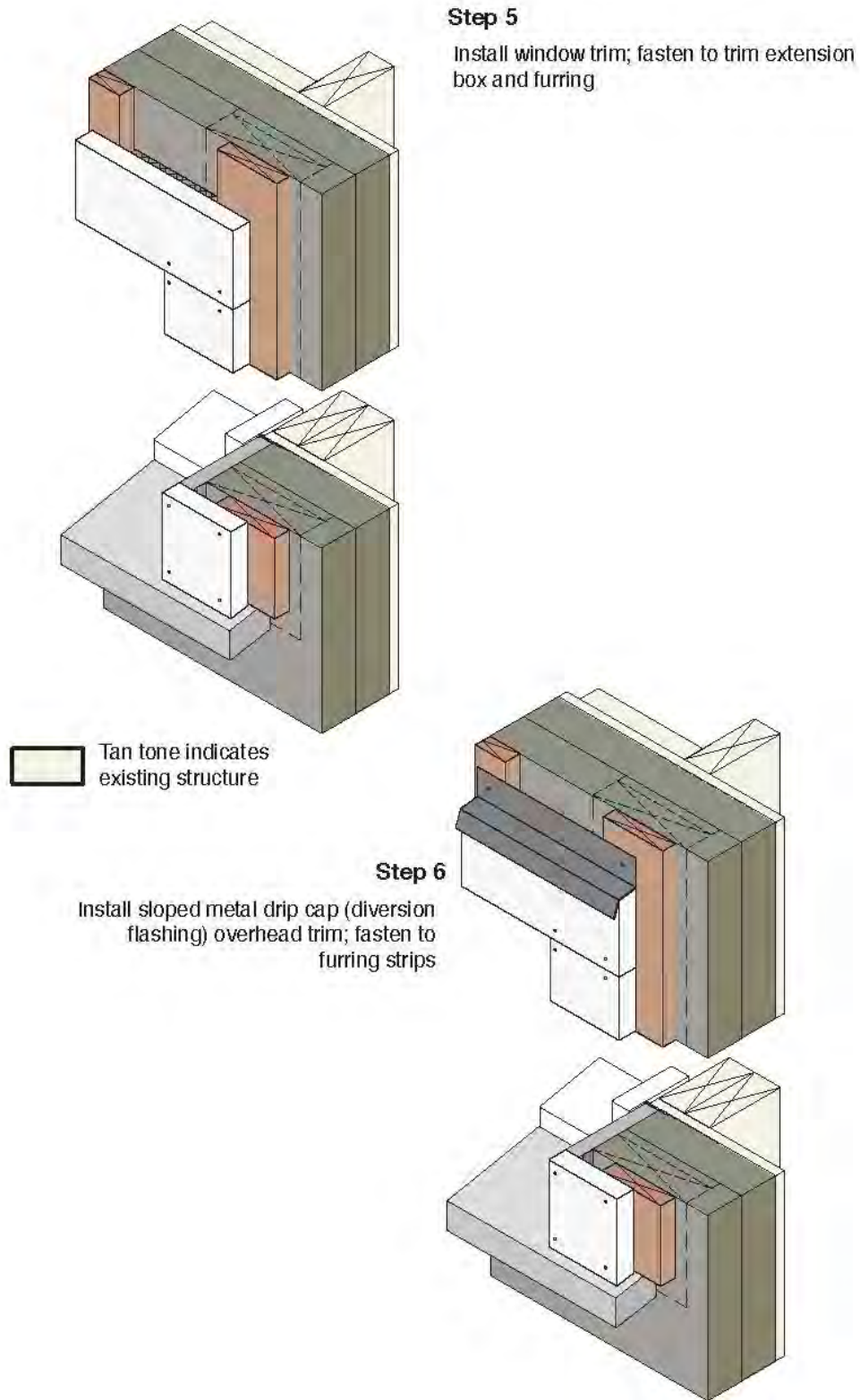

Figure 42. Steps 5 and 6 of exterior trim installation sequence for window in a high performance mineral fiber retrofit wall assembly

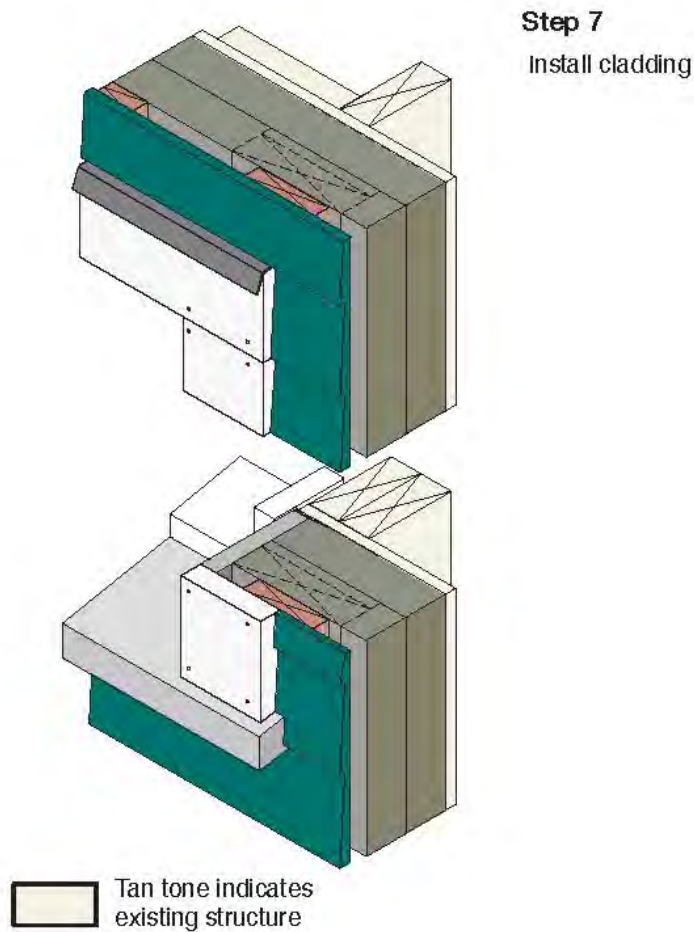
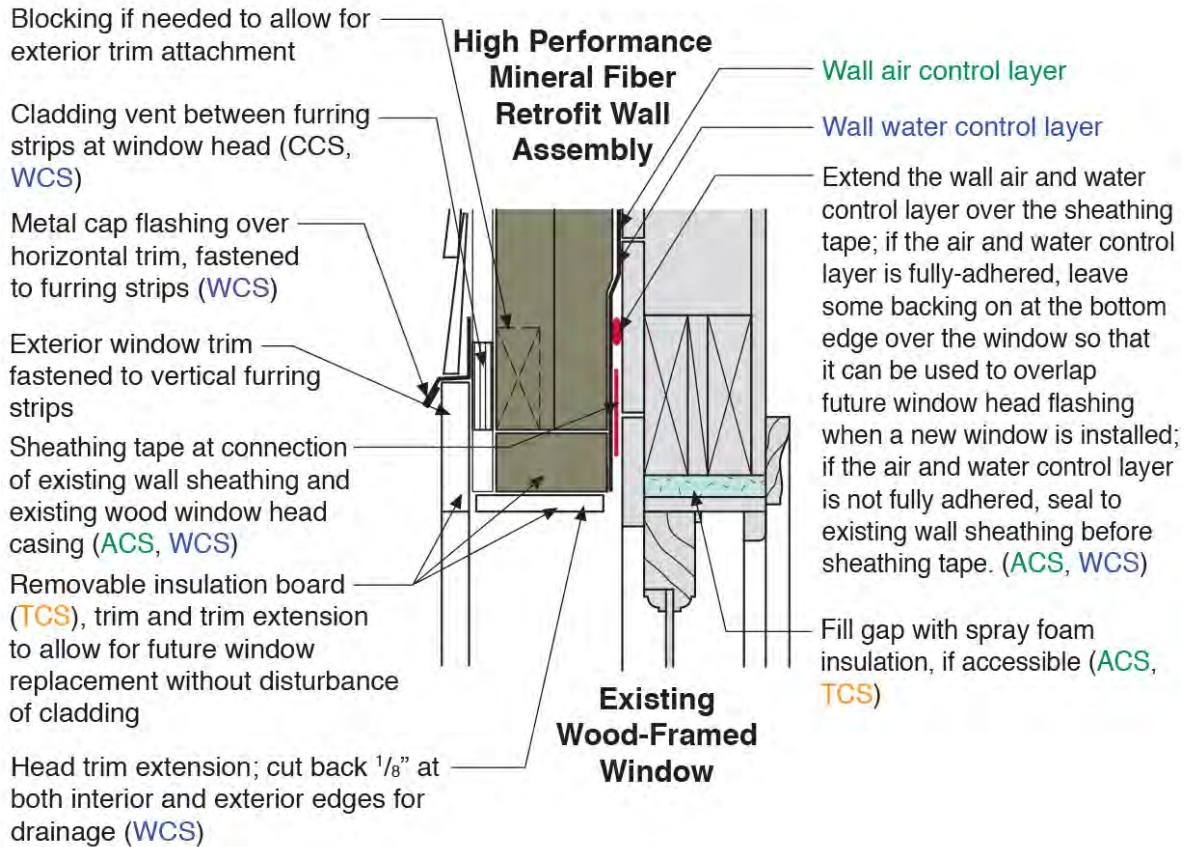

Figure 43. Step 7 of exterior trim installation sequence for window in a high performance mineral fiber retrofit wall assembly

Figure 42 through Figure 46 show the implementation of the high performance mineral fiber retrofit wall assembly at a window opening where the existing window is to remain in place. There may be many reasons for leaving an existing window in place; however, this prevents the contractor from ensuring that the window opening is properly flashed. The air control and water control transitions around a window that remains in place are not as robust as for a window opening that can be flashed and lined as part of the retrofit project. The exterior trim sequence illustrated above is applicable to this condition.



WCS Water control system	TCS Thermal control system	Gray tone indicates existing components
ACS Air control system	CCS Critter control system	
VCS Vapor control system	Mineral fiber insulation board	

Figure 44. Schematic detail for window head of an existing window remaining in place in a high performance mineral fiber retrofit wall assembly

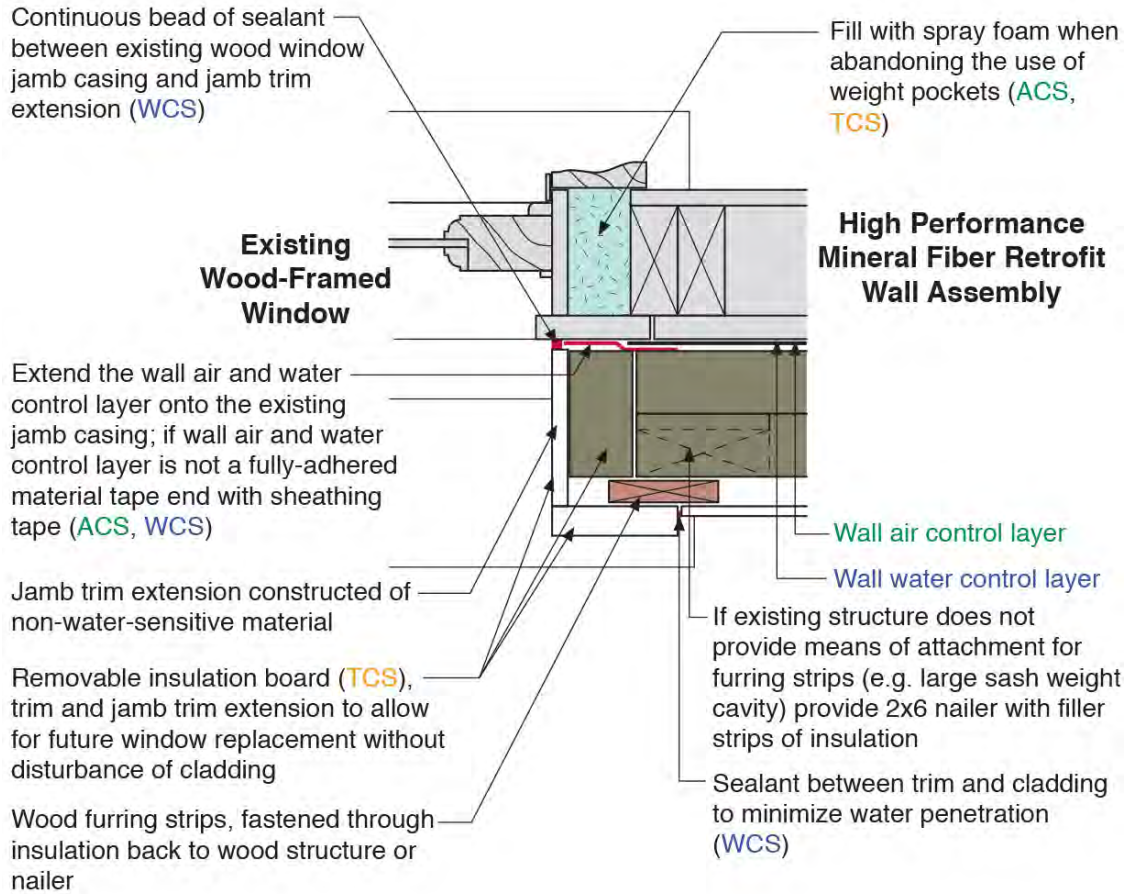

WCS	Water control system	TCS	Thermal control system	Gray tone indicates existing components
ACS	Air control system	CCS	Critter control system	
VCS	Vapor control system	Mineral fiber insulation board		

Figure 45. Schematic detail for window jamb of an existing window remaining in place in a high performance mineral fiber retrofit wall assembly

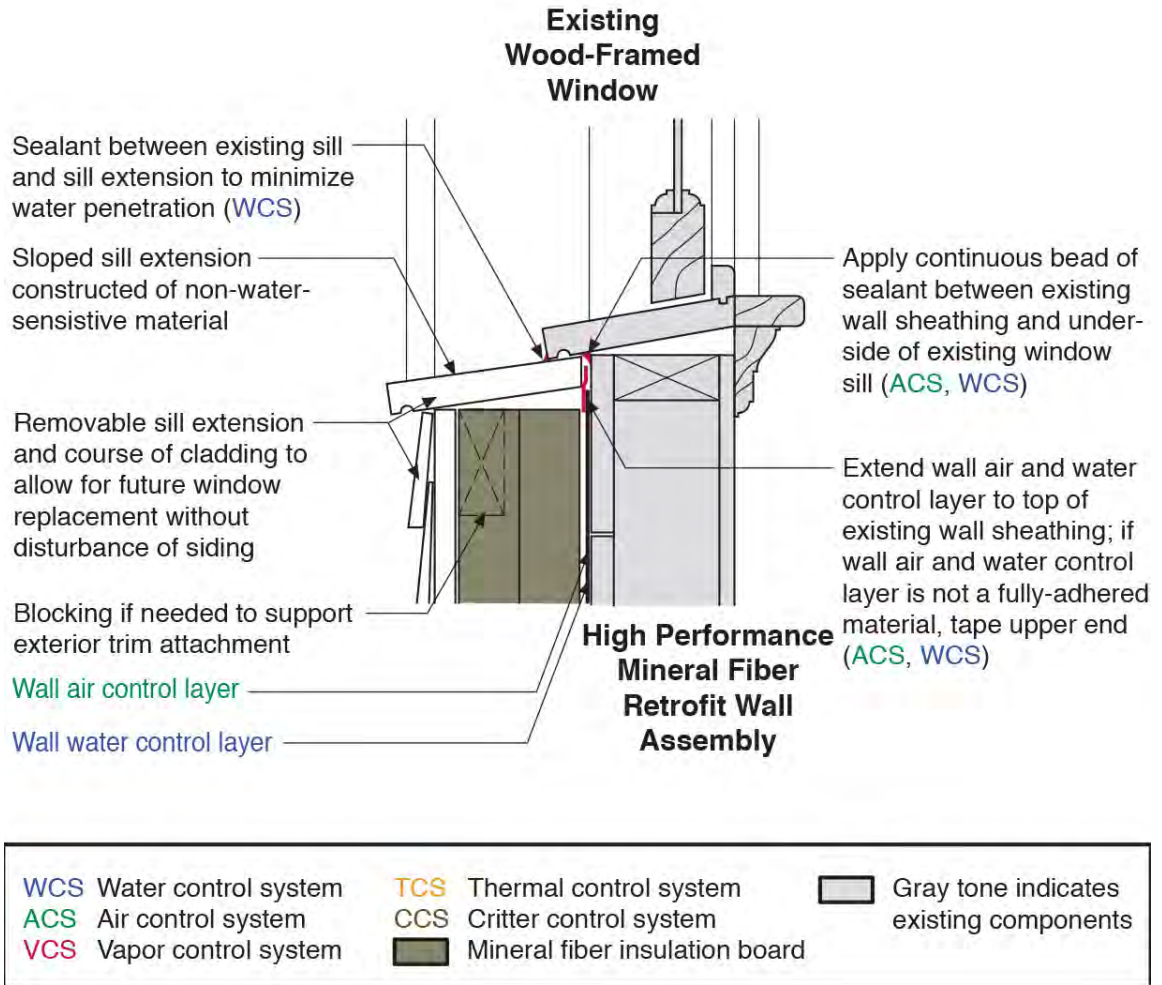

Figure 46. Schematic detail for window sill of an existing window remaining in place in a high performance mineral fiber retrofit wall assembly

Figure 47 through Figure 59 show the installation of a new door or the reinstatement of a door in the high performance mineral fiber retrofit wall assembly.

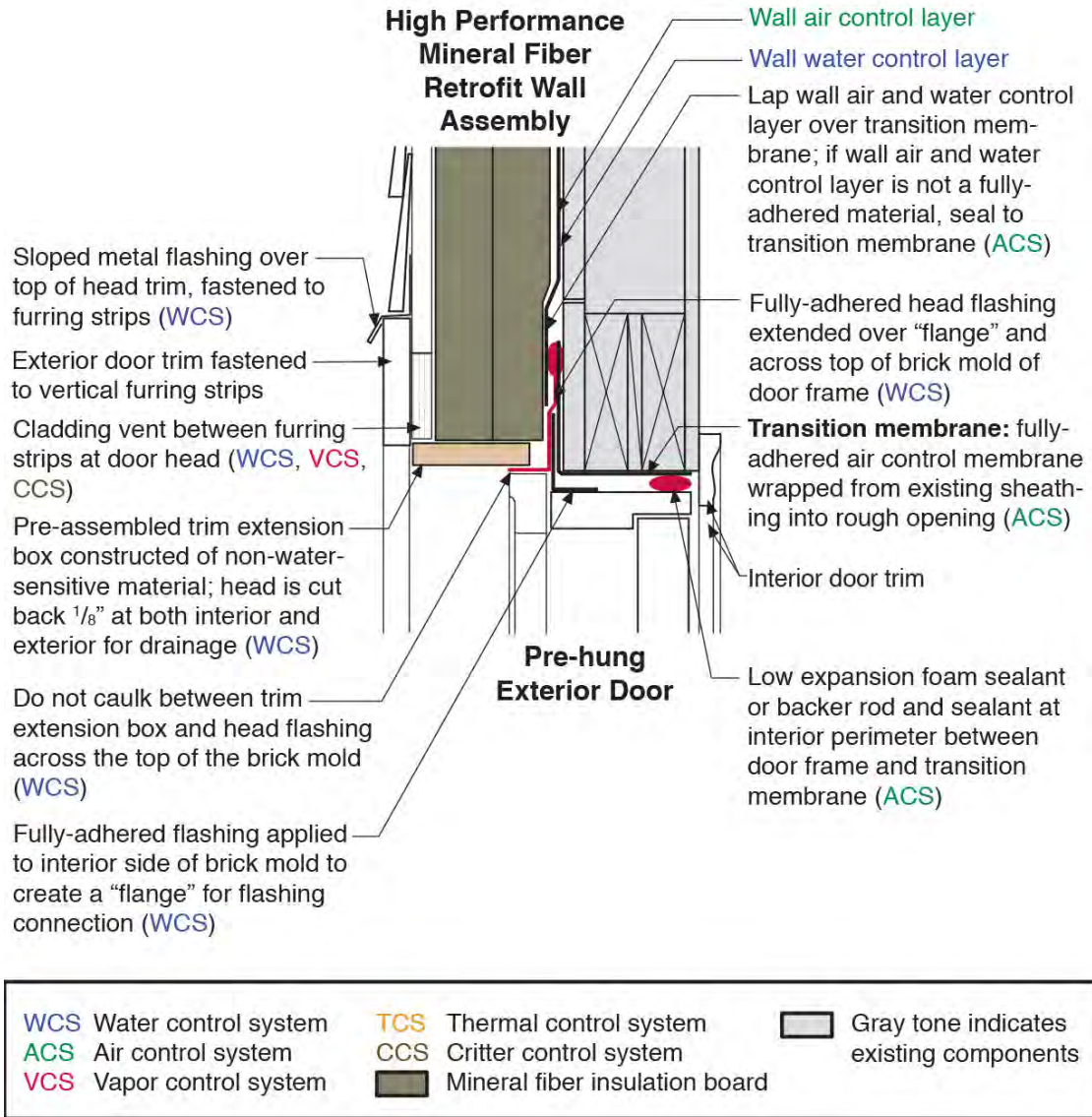
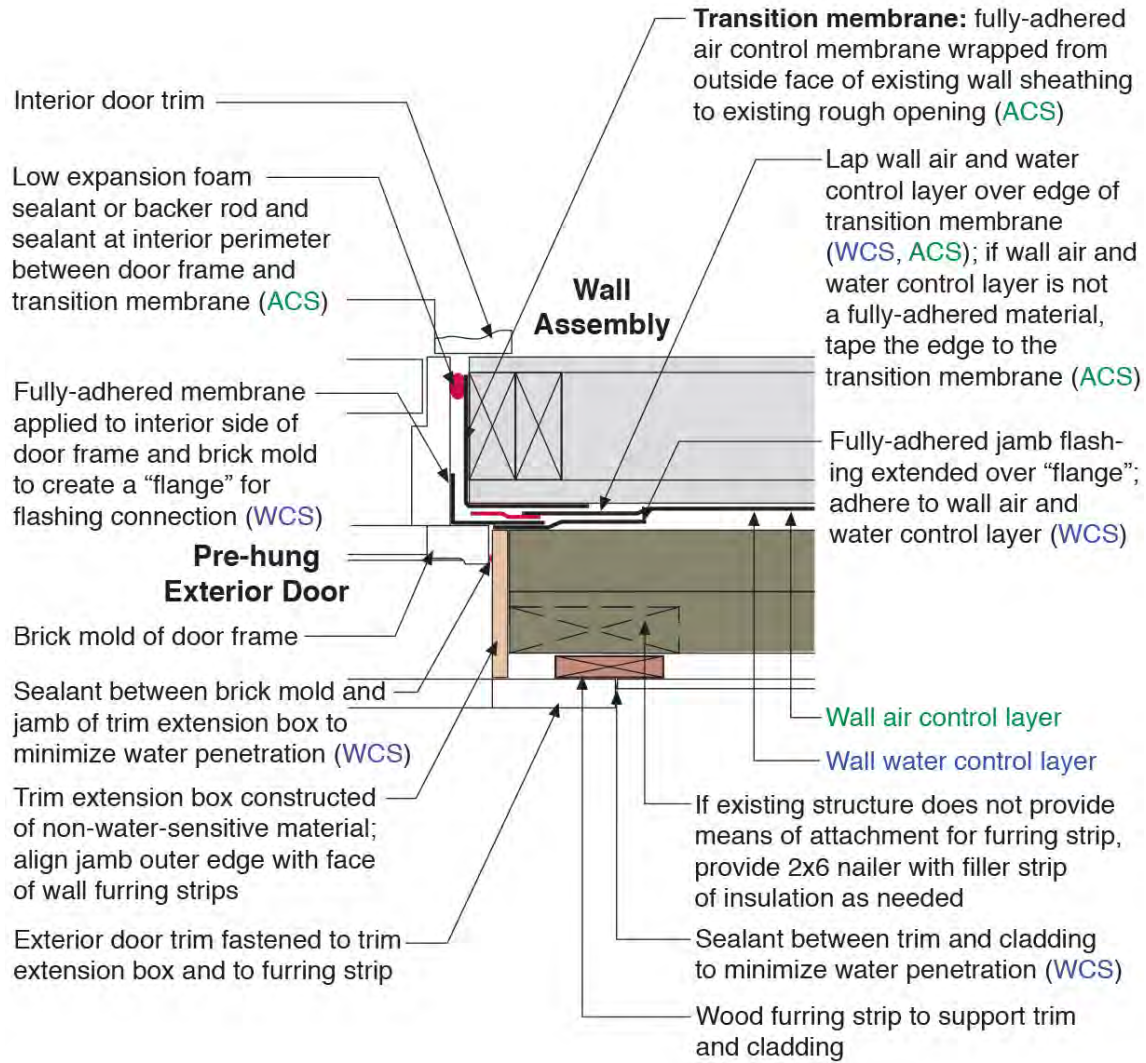

Figure 47. Schematic detail for door head of new door or reinstalled door in a high performance mineral fiber retrofit wall assembly

Note: See installation sequence for new door or reinstalled door in a high performance mineral fiber retrofit wall assembly for flashing installation details.





WCS Water control system	TCS Thermal control system	 Gray tone indicates existing components
ACS Air control system	CCS Critter control system	
VCS Vapor control system	 Mineral fiber insulation board	

Figure 48. Schematic detail for door jamb of new door or reinstalled door in a high performance mineral fiber retrofit wall assembly



WCS	Water control system	TCS	Thermal control system	Gray tone	indicates existing components
ACS	Air control system	CCS	Critter control system	Dark gray tone	Mineral fiber insulation board
VCS	Vapor control system				

Figure 49. Schematic detail for door sill of new door or reinstalled door in a high performance mineral fiber retrofit wall assembly

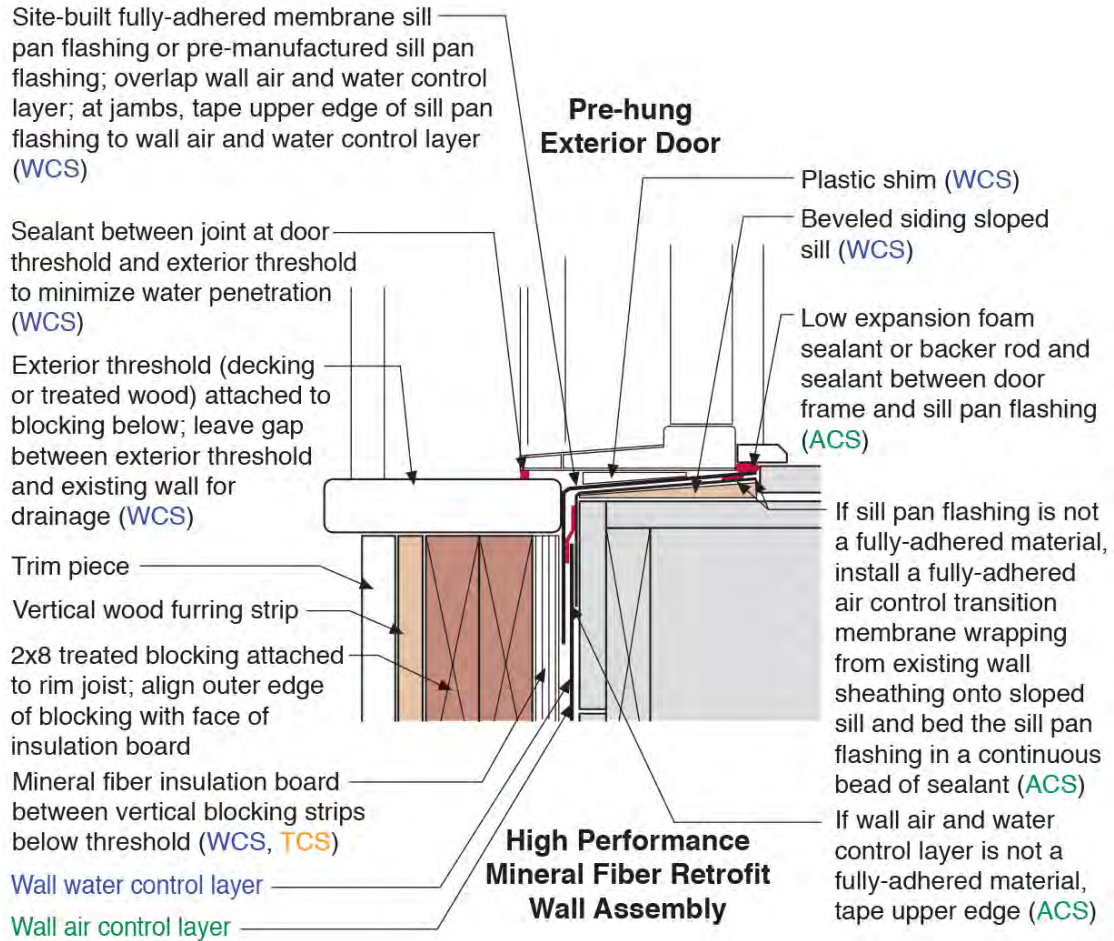
Step 1

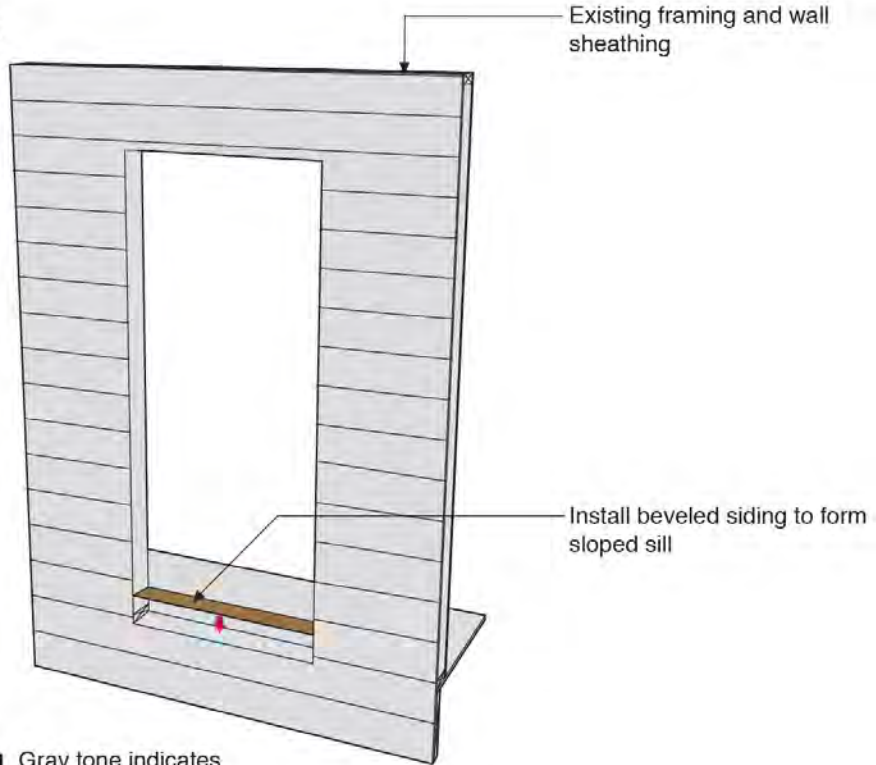

Step 2

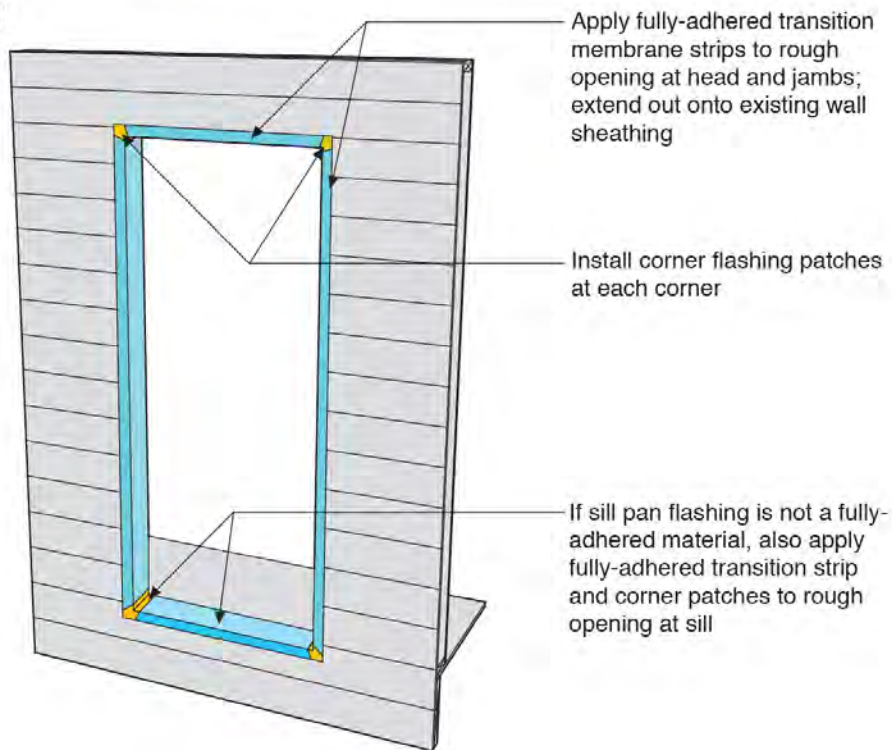
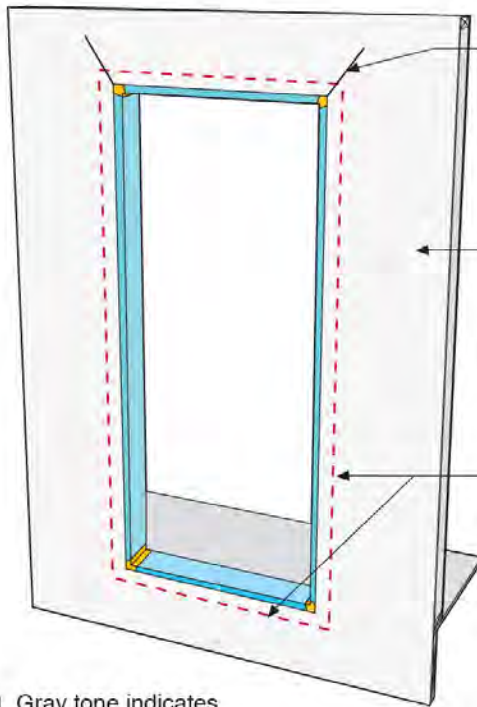

Figure 50. Steps 1 and 2 of installation sequence for new door or reinstalled door in a high performance mineral fiber retrofit wall assembly

Step 3



Step 3C: Cut air and water control layer at head to create a temporary fold-up flap

Step 3A: Install air and water control layer over existing sheathing; overlap the transition membrane installed in Step 2

Step 3B: Tape or seal edges of air and water control layer to the transition membrane at jambs and sill; leave edge at head untaped

 Gray tone indicates existing components

Step 4

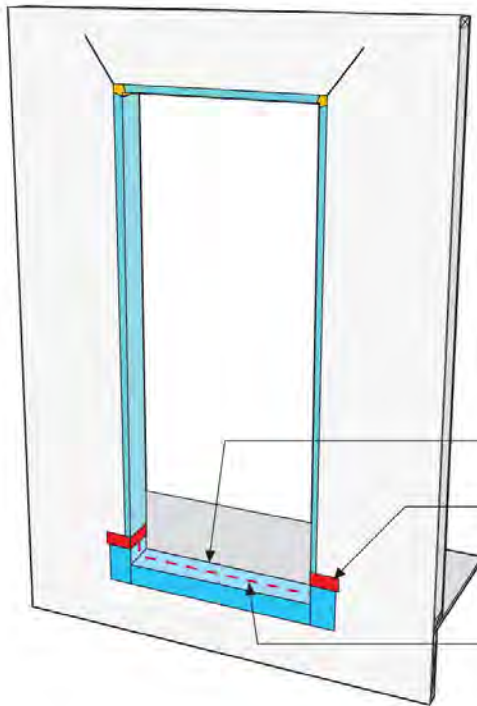

Install sill pan flashing

Tape upper edge of sill pan flashing at jamb

If sill pan flashing is not a fully-adhered material, bed in a continuous bead of sealant

Figure 51. Steps 3 and 4 of installation sequence for new door or reinstalled door in a high performance mineral fiber retrofit wall assembly

Step 5

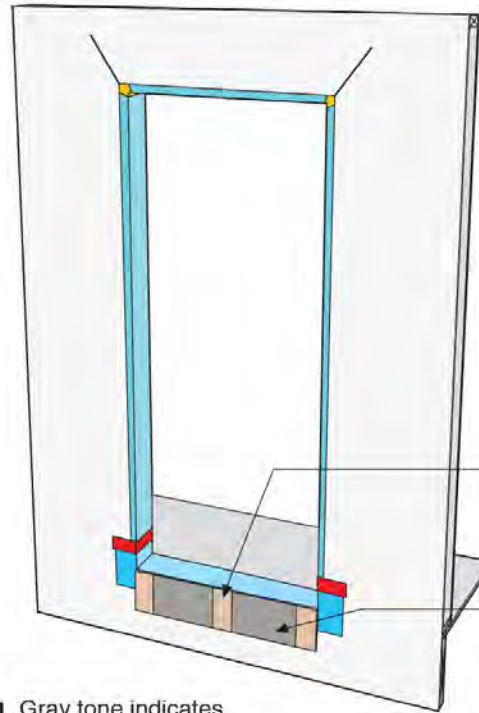

Install vertical blocking strips below opening

Install mineral fiber insulating sheathing between blocking strips; insulating sheathing and blocking strips to be of similar thickness

Gray tone indicates existing components

Step 6

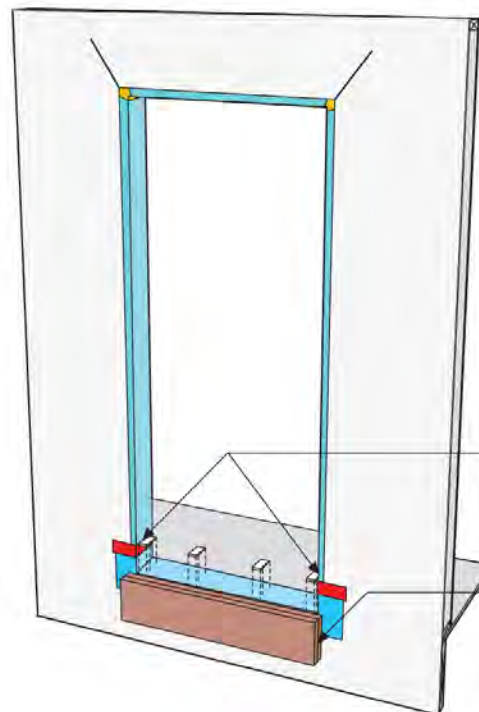

Install plastic shims, leave drainage gap at corners

Install 2x8 blocking over blocking strips to support exterior threshold

Figure 52. Steps 5 and 6 of installation sequence for new door or reinstalled door in a high performance mineral fiber retrofit wall assembly

Step 7

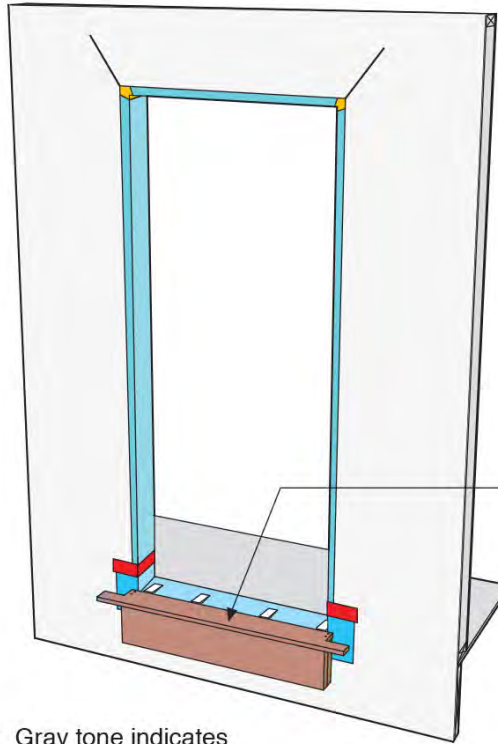

Attach exterior threshold to blocking; exterior threshold ends are notched to allow insulating sheathing behind

 Gray tone indicates existing components

Step 8 (reverse view)

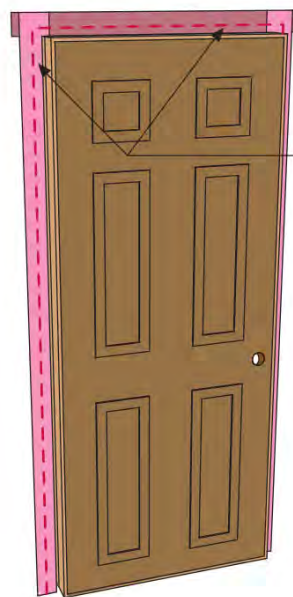

Interior side of door

Apply fully-adhered flashing to interior side of brick mold of door frame to create “flanges” first at the head and then at the jambs of door

Figure 53. Steps 7 and 8 of installation sequence for new door or reinstalled door in a high performance mineral fiber retrofit wall assembly

Step 9



Step 9A: Temporarily fold up flap of air and water control layer

Step 9B: Install door with "flanges" over existing sheathing; ensure plumb, level and square; shim as required

 Gray tone indicates existing components

Step 10



Step 10B: Install head flashing over head "flange"; overlap top of jamb flashing

Step 10A: Install jamb flashing over jamb "flange," both sides

Step 10C: Install door sill extension

Figure 54. Steps 9 and 10 of installation sequence for new door or reinstalled door in a high performance mineral fiber retrofit wall assembly

Step 11

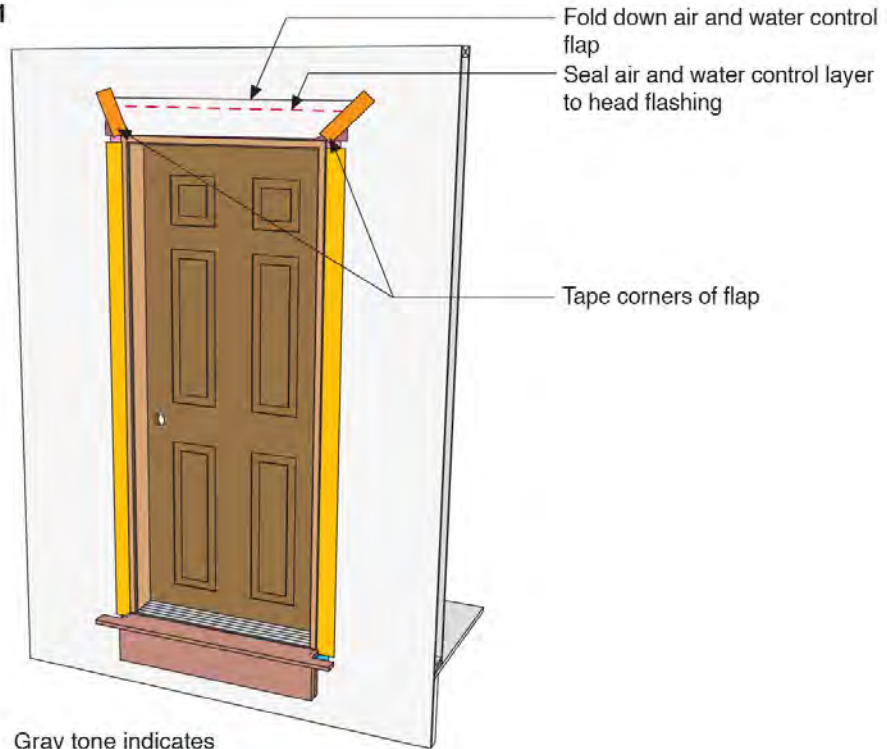

Step 12 (reverse view)

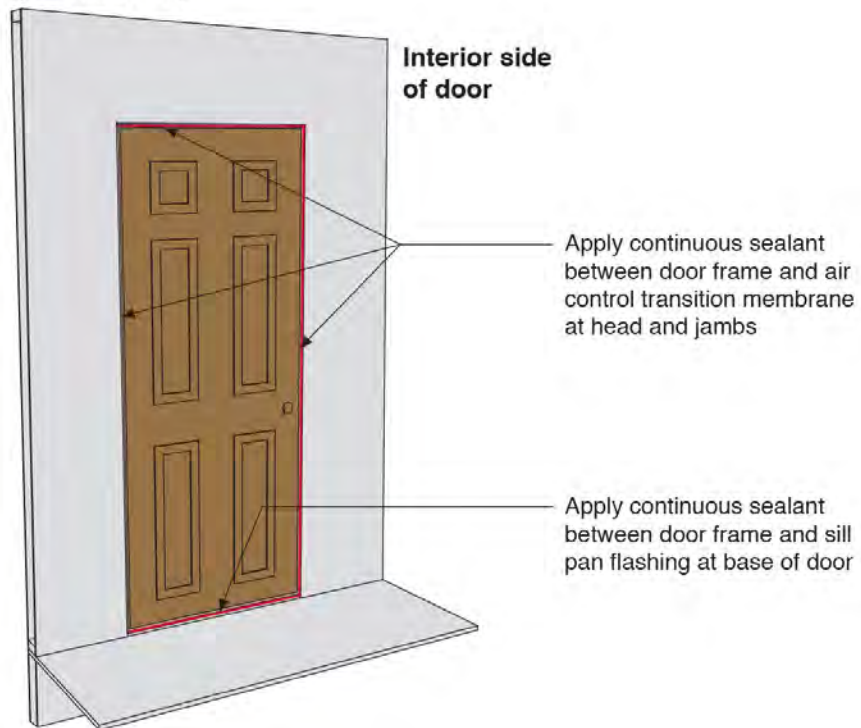
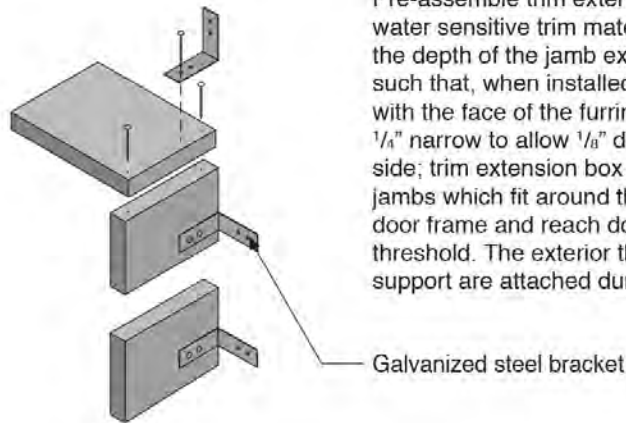



Figure 55. Steps 11 and 12 of installation sequence for new door or reinstalled door in a high performance mineral fiber retrofit wall assembly

Step 1

Pre-assemble trim extension box using non-water sensitive trim material (e.g. cellular PVC); the depth of the jamb extensions should be such that, when installed, the outer edge aligns with the face of the furring strips; cut head piece $\frac{1}{4}$ " narrow to allow $\frac{1}{8}$ " drainage gap to either side; trim extension box consists of head and jambs which fit around the brick mold of the door frame and reach down to the exterior threshold. The exterior threshold and threshold support are attached during door installation.



 Tan tone indicates existing components

Step 2

Attach trim extension box after door is installed and integrated into air and water control layer.

$\frac{1}{8}$ " gap at interior and exterior of head of trim extension box for drainage

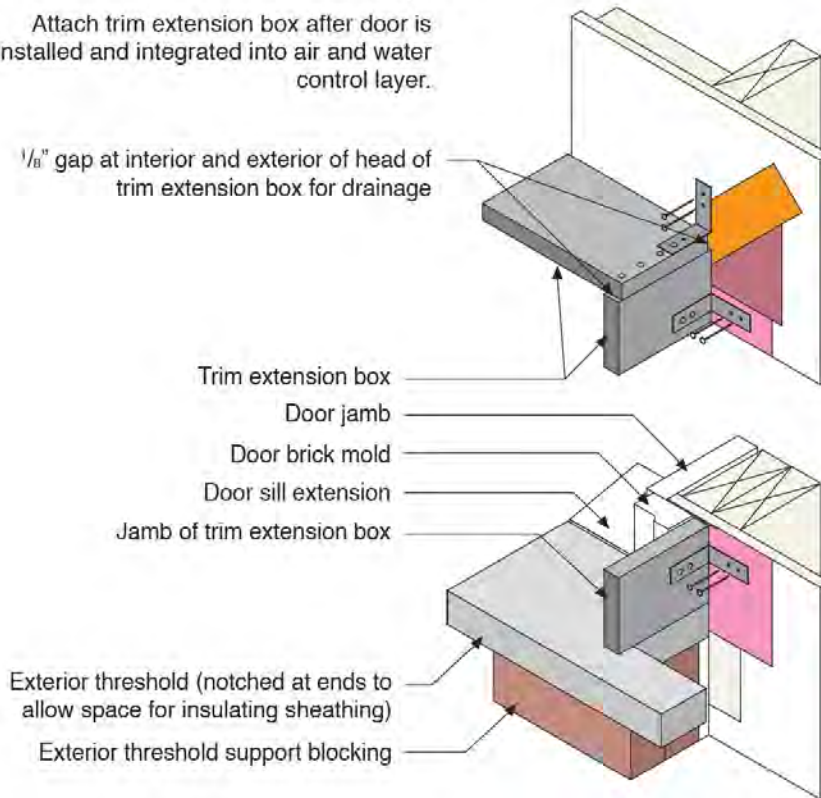

Figure 56. Steps 1 and 2 of exterior trim installation sequence for door in a high performance mineral fiber retrofit wall assembly

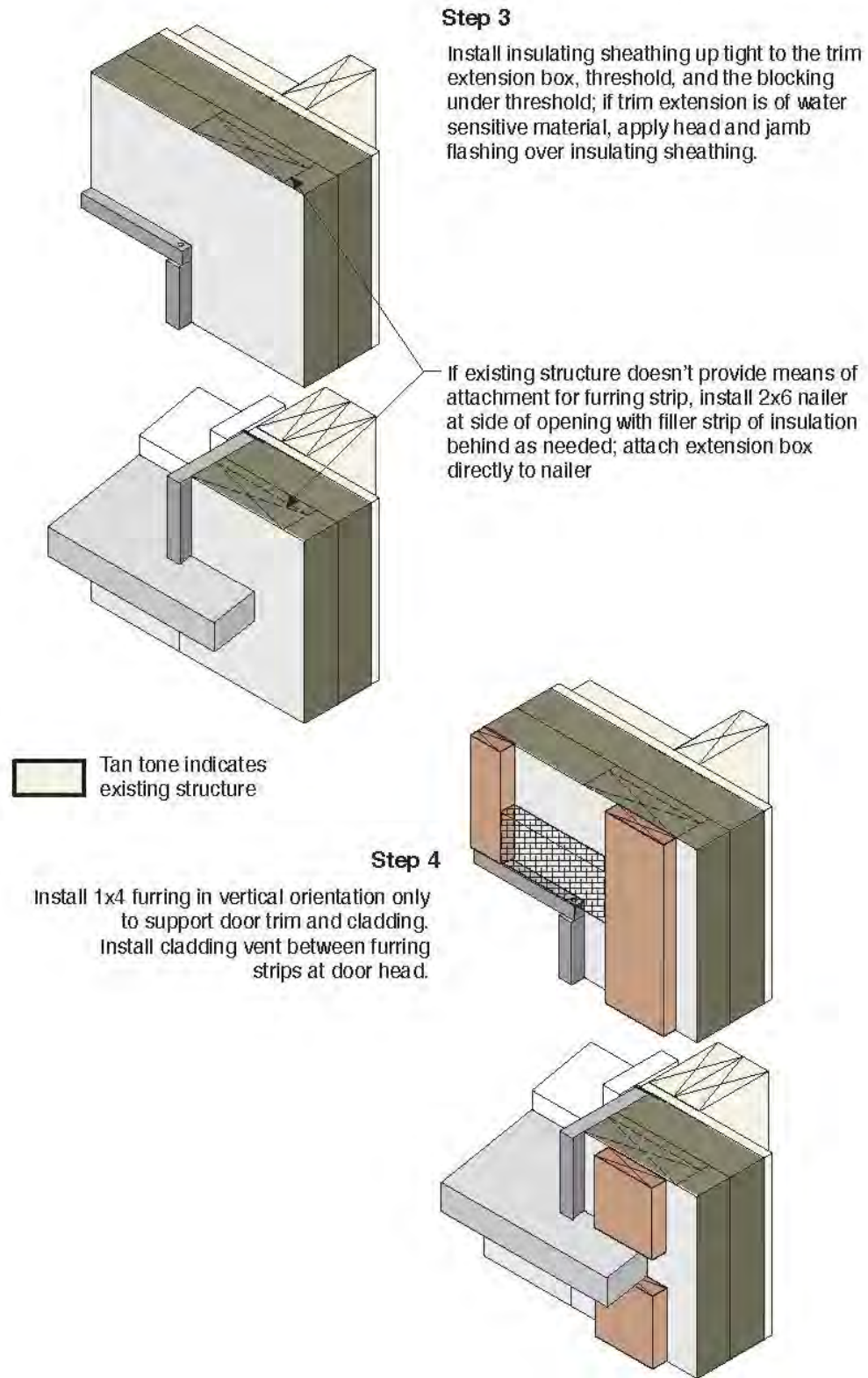

Figure 57. Steps 3 and 4 of exterior trim installation sequence for door in a high performance mineral fiber retrofit wall assembly

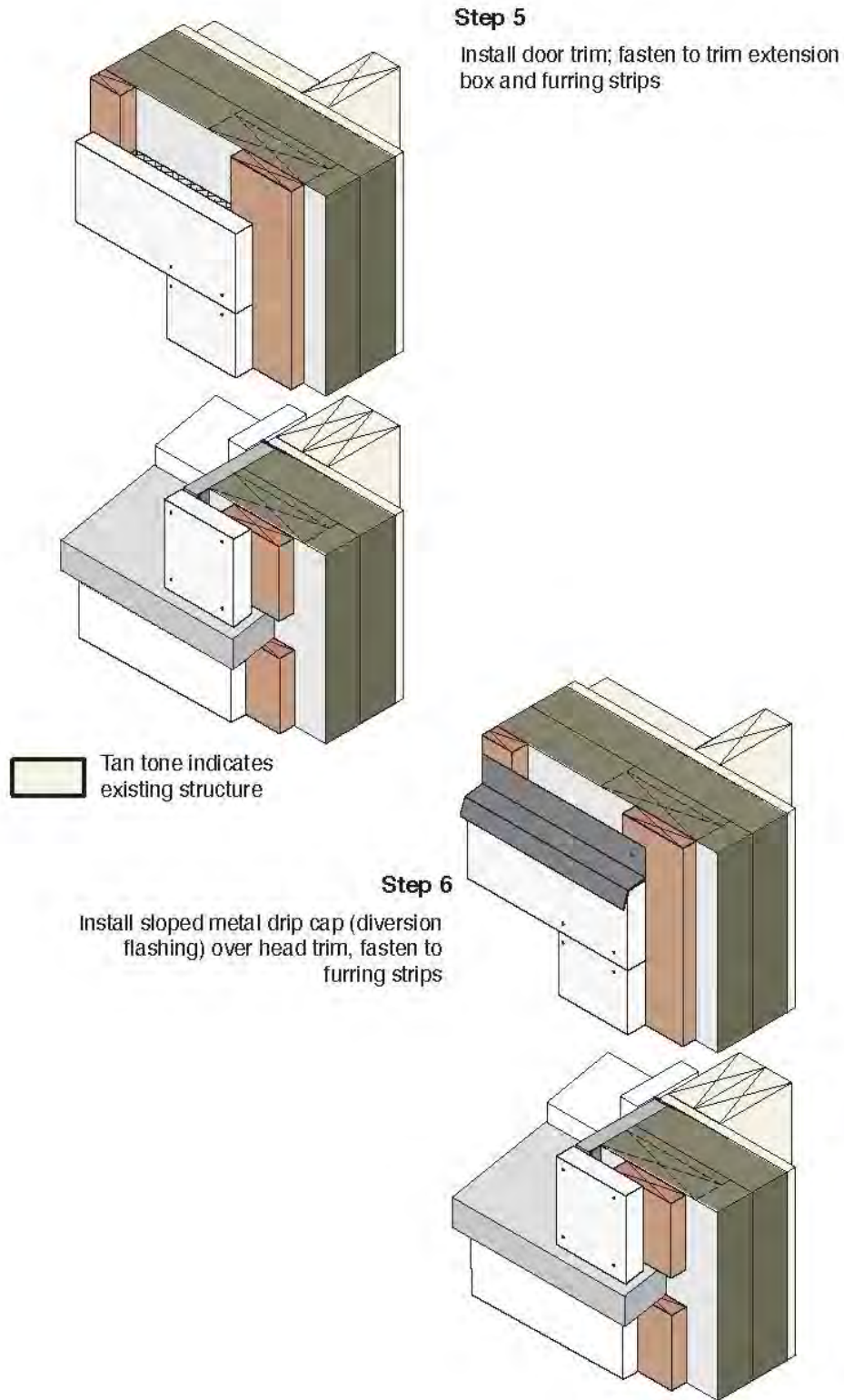

Figure 58. Steps 5 and 6 of exterior trim installation sequence for door in a high performance mineral fiber retrofit wall assembly

Step 7
Install cladding

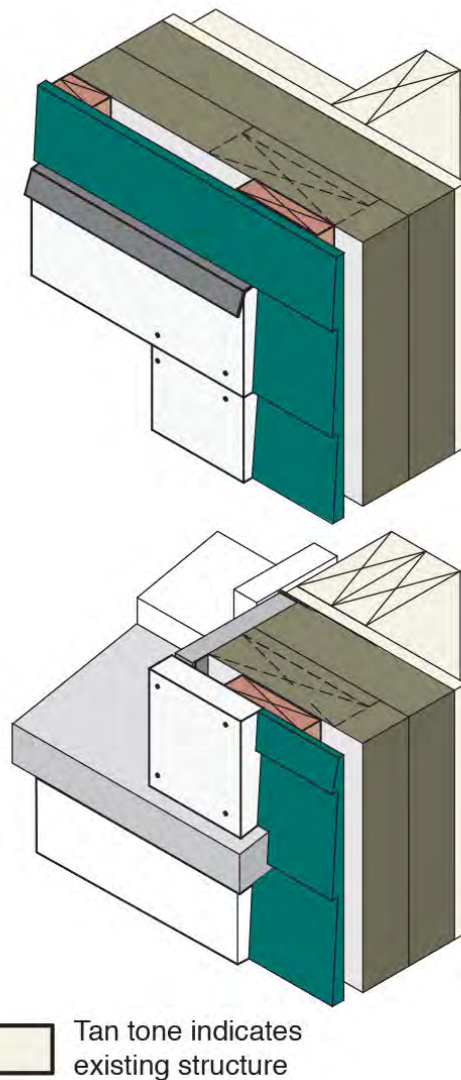
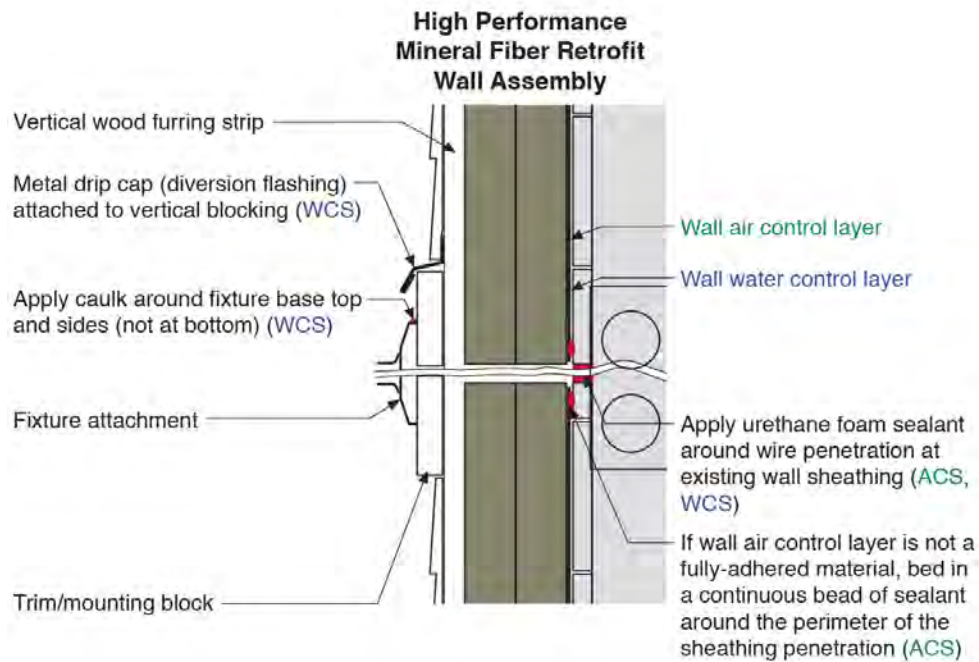
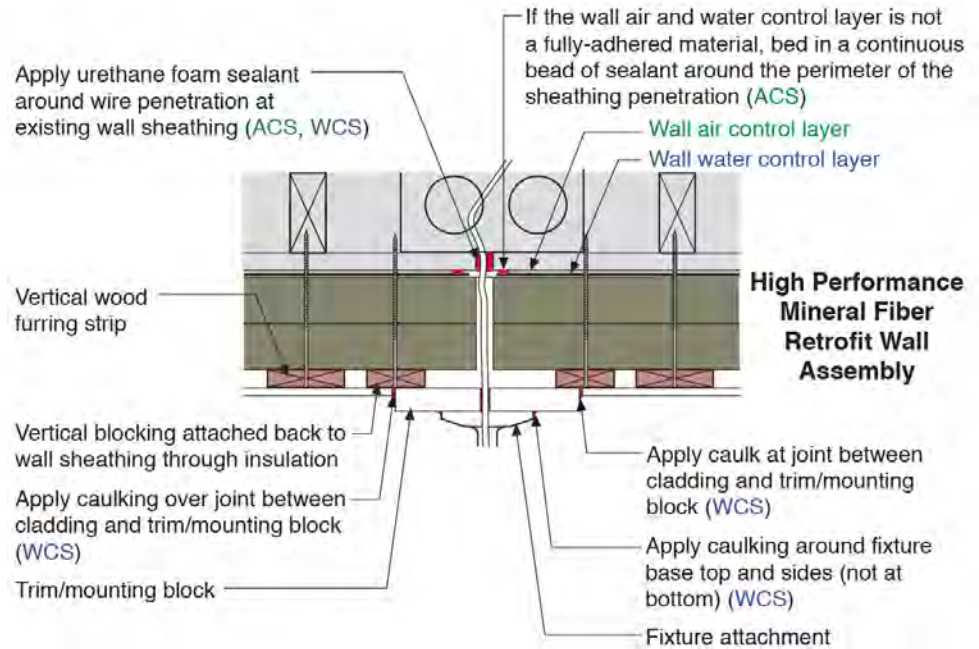

Figure 59. Step 7 of exterior trim installation sequence for door in a high performance mineral fiber retrofit wall assembly

Figure 60 through Figure 67 show the treatment of typical wall penetrations through the high performance mineral fiber retrofit wall assembly.



WCS	Water control system	TCS	Thermal control system	Gray tone	indicates existing components
ACS	Air control system	CCS	Critter control system	Mineral fiber	insulation board
VCS	Vapor control system				

Figure 60. Schematic plan (above) and section (below) details for wire penetration and fixture mount in a high performance mineral fiber retrofit wall assembly

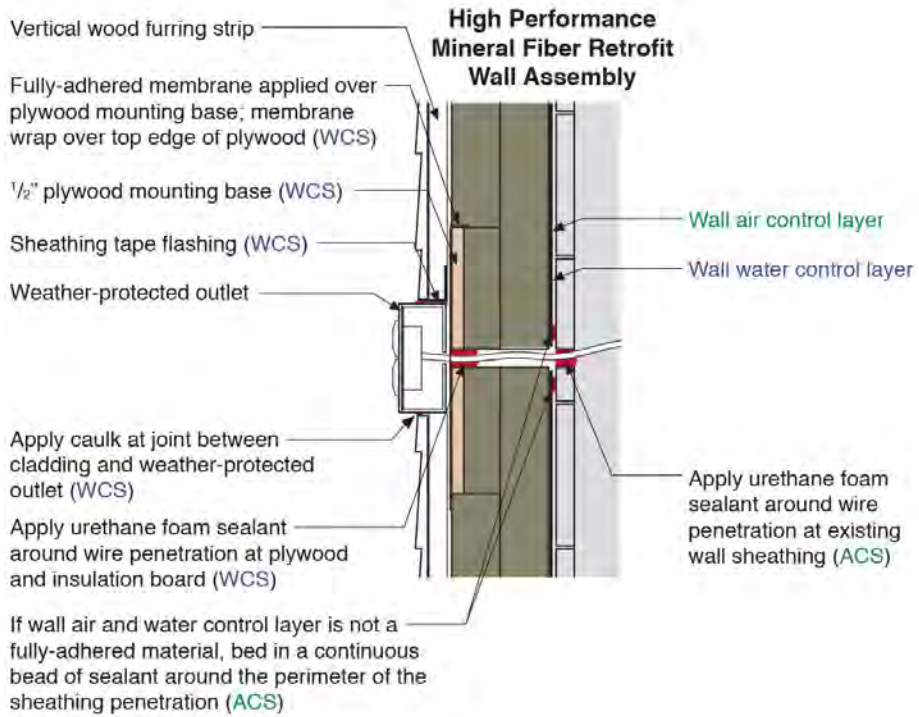
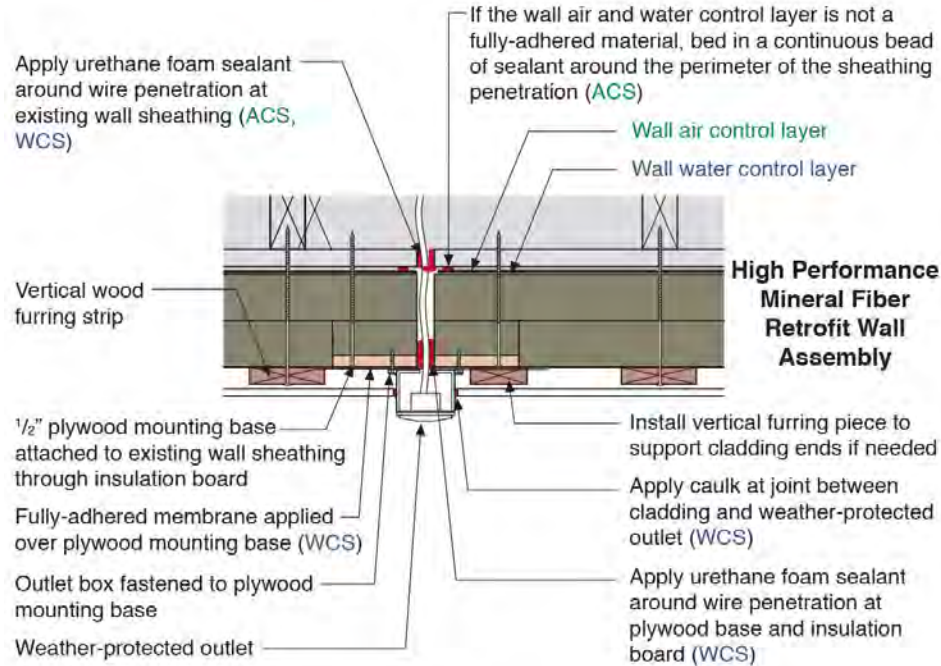

WCS Water control system	TCS Thermal control system	Gray tone indicates existing components
ACS Air control system	CCS Critter control system	
VCS Vapor control system	Mineral fiber insulation board	

Figure 61. Schematic plan and section details for wire penetration and exterior outlet box mount in a high performance mineral fiber retrofit wall assembly

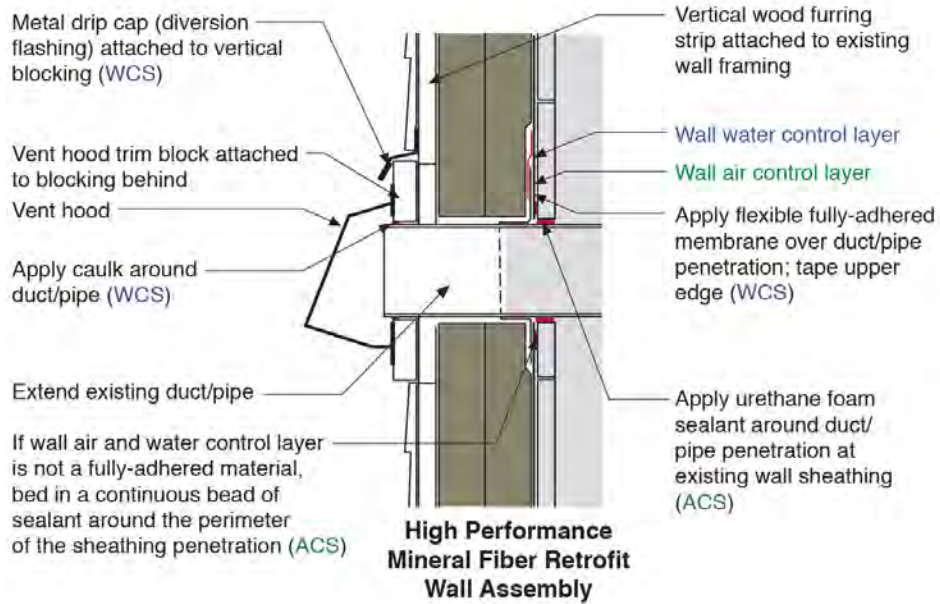
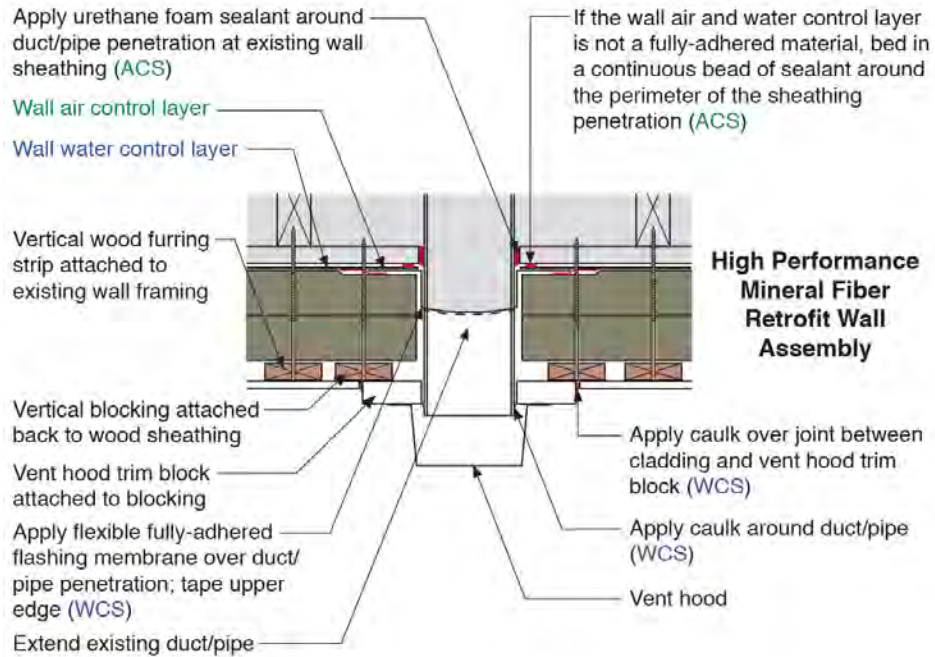

WCS	Water control system	TCS	Thermal control system	Gray tone	indicates existing components
ACS	Air control system	CCS	Critter control system		
VCS	Vapor control system		Mineral fiber insulation board		

Figure 62. Schematic plan and section details for duct penetration and vent hood trim mount in a high performance mineral fiber retrofit wall assembly

Step 1

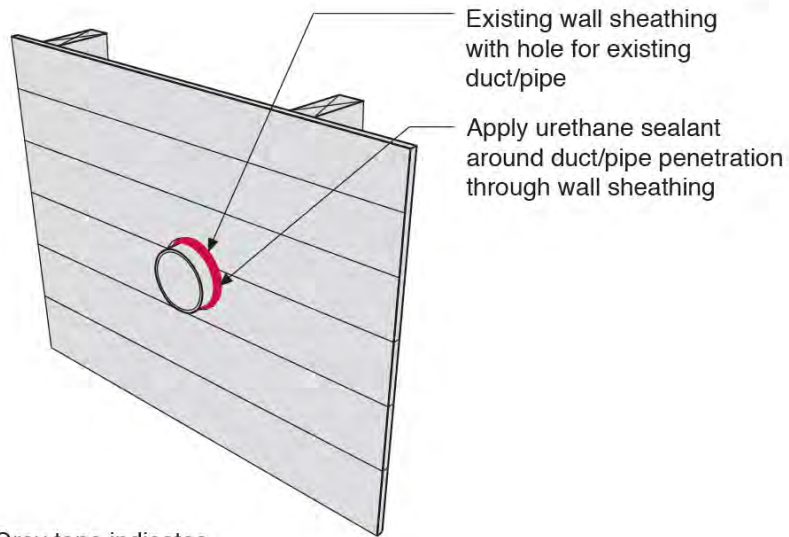

Gray tone indicates existing components

Step 2

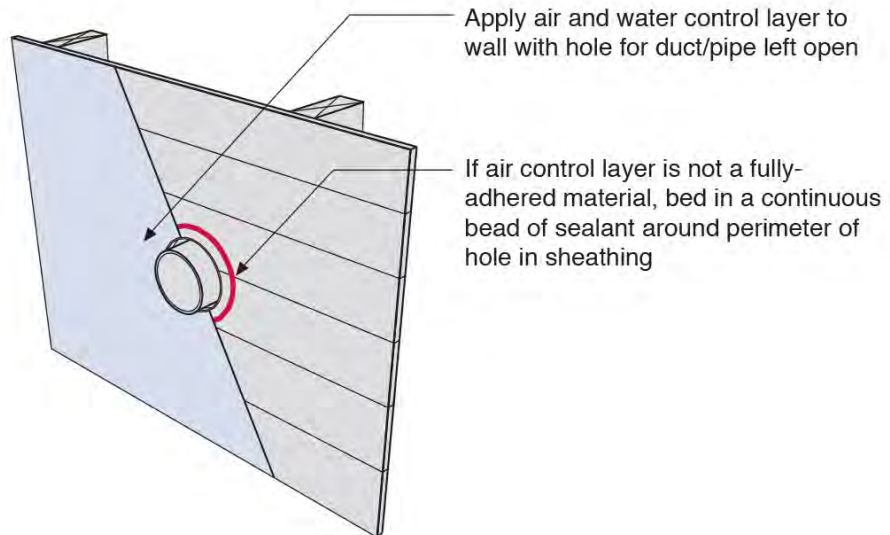
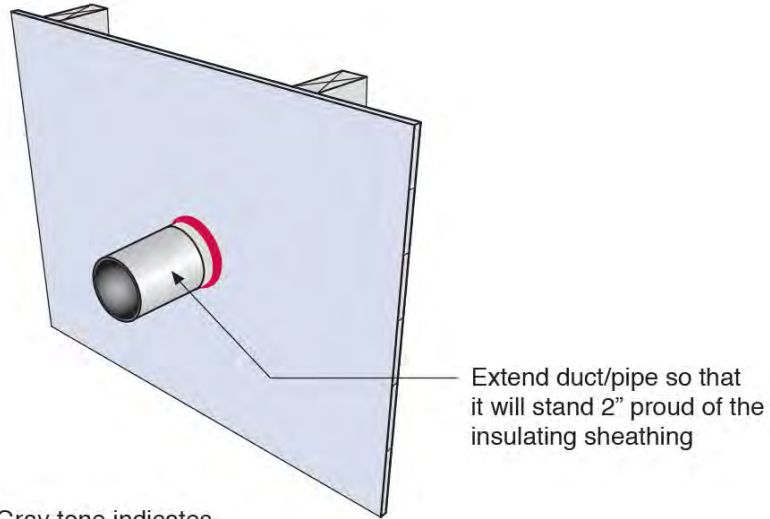



Figure 63. Steps 1 and 2 of sequence for treatment of duct/pipe penetration through a high performance mineral fiber retrofit wall assembly

Step 3



 Gray tone indicates existing components

Step 4

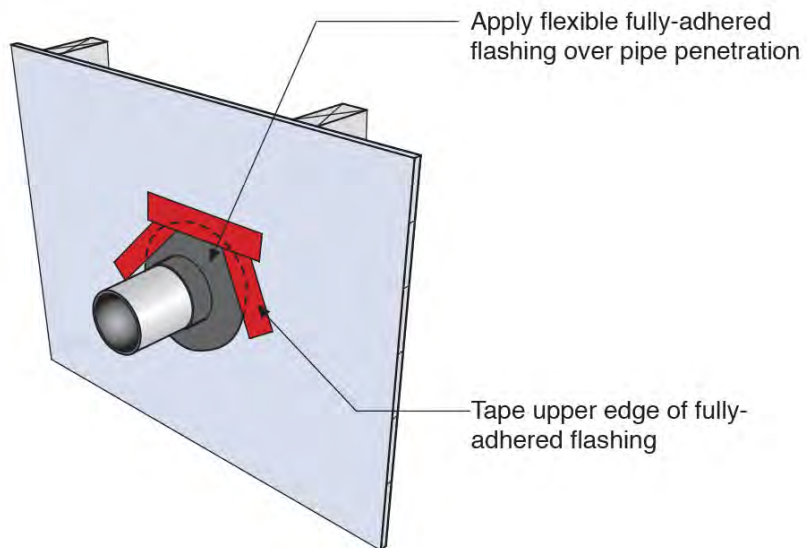
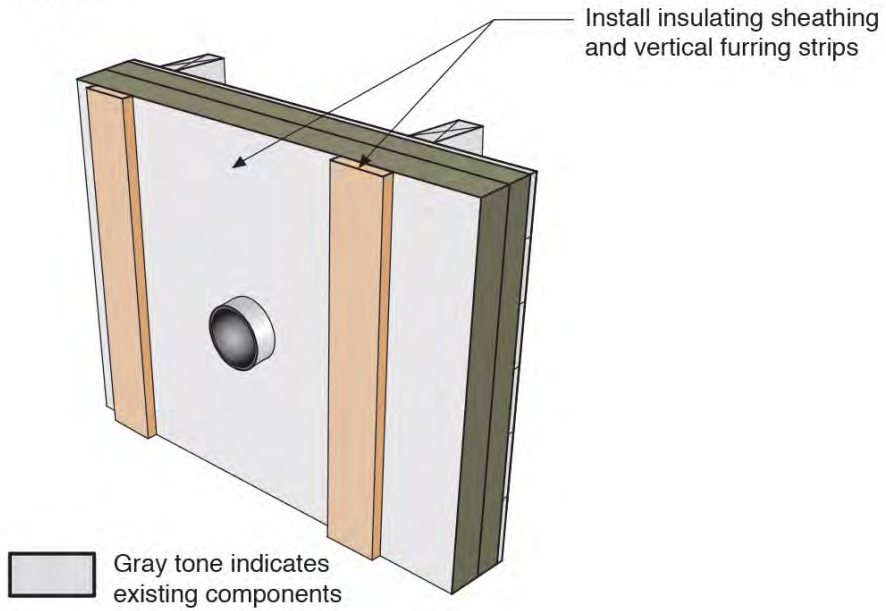

Figure 64. Steps 3 and 4 of sequence for treatment of duct/pipe penetration through a high performance mineral fiber retrofit wall assembly

Step 5



Step 6

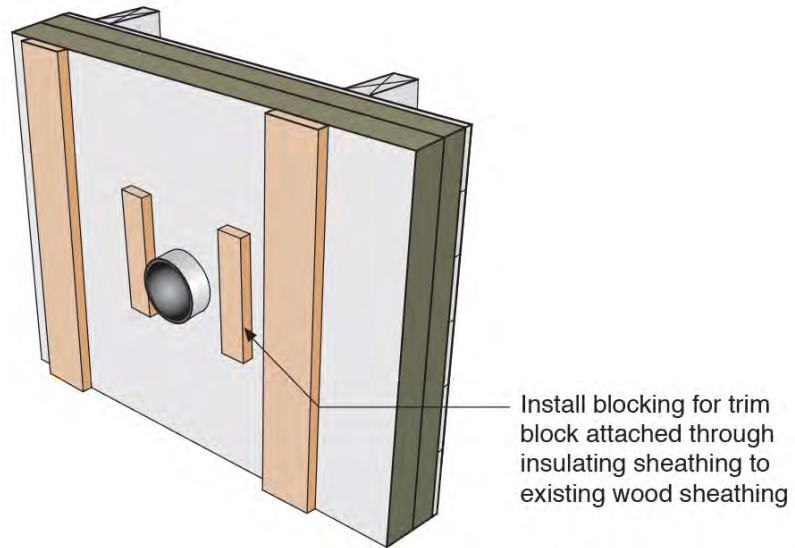
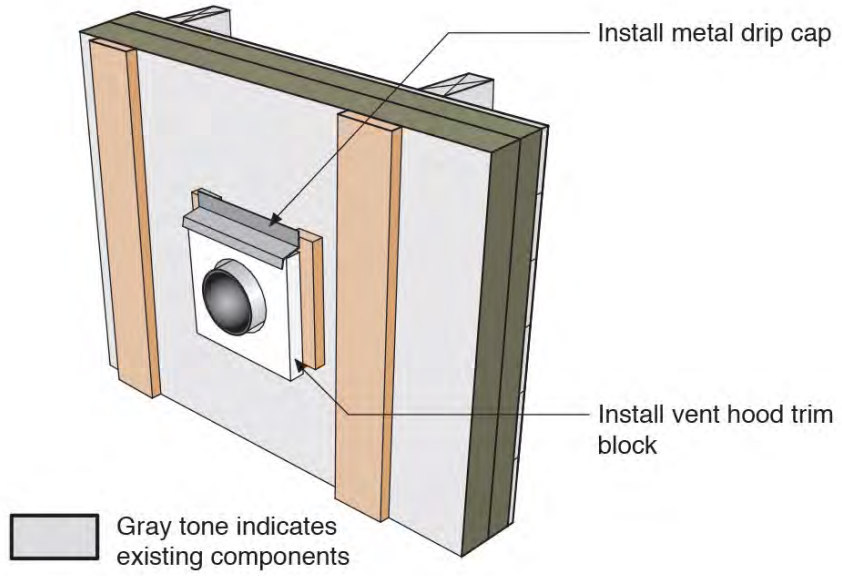

Figure 65. Steps 5 and 6 of sequence for treatment of duct/pipe penetration through a high performance mineral fiber retrofit wall assembly

Step 7



Step 8

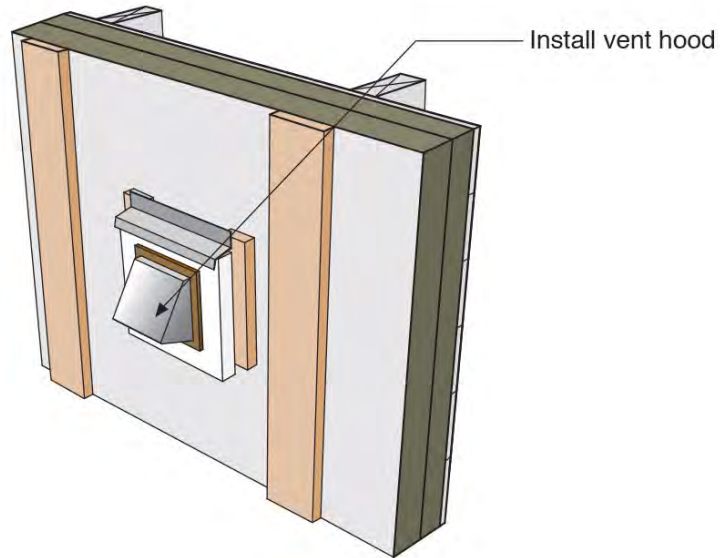

Figure 66. Steps 7 and 8 of sequence for treatment of duct/pipe penetration through a high performance mineral fiber retrofit wall assembly

Step 9

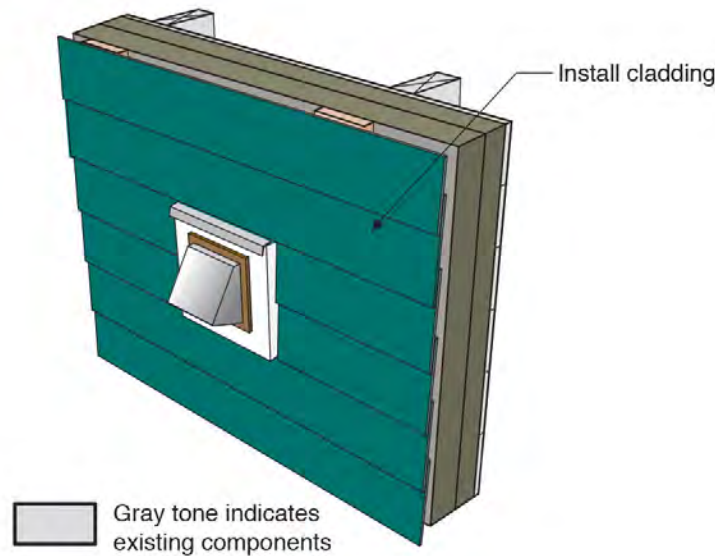

Figure 67. Step 9 of sequence for treatment of duct/pipe penetration through a high performance mineral fiber retrofit wall assembly

4.3 High Performance Mineral Fiber Retrofit Foundation Wall Assembly

4.3.1 Scope of Work

1. Locate underground utilities and implement measures to ensure their protection. Verify safe conditions for perimeter excavation.
2. Excavate the foundation perimeter to a depth and width required to implement the wall retrofit and foundation skirt measures. Install clean aggregate for insulated foundation skirt. Grade bottom of excavation to slope at least 5% away from foundation.
3. Install metal closure/transition flashing at top of foundation wall.
4. Install non-moisture-sensitive rigid insulation at bottom of excavation as required.
5. Install ground roof/foundation skirt and secure high end to foundation with retaining bar.
6. Install drainpipe at low end of ground roof/foundation skirt. Slope to daylight outlet or storm water collection. DO NOT connect drainpipe to foundation drain.
7. Install mineral fiber insulation board with protective finish to the exterior of the foundation wall.
8. Backfill excavation to within 4 in. of finished grade with free-draining backfill.
9. Install a drip trench adjacent to foundation wall and separated from backfill/soil with a durable filter fabric.

4.3.2 Climate-Specific Factors

In climate zone 5 and above, the ground roof/foundation skirt for a slab-on-grade foundation should be insulated. The ground roof/foundation skirt should be insulated in climate zone 2 and

above if the home has a crawlspace or basement. The level of recommended insulation is as follows:

- R-5 in climate zone 2
- R-7.5 in climate zones 3 and 4
- R-10 minimum in climate zones 5 and 6
- R-15 minimum in climate zone 7
- R-20 minimum in climate zone 8.

The insulation used must be approved for below-grade applications (e.g., XPS or foamed glass) and placed over a capillary break consisting of a sloped bed of clean aggregate.

4.3.3 Field Inspection

Identify and address risks to occupants or the building that could be aggravated by the work. Verify safe working conditions. Determine whether the building has more urgent problems that must be addressed. Determine the feasibility of the retrofit solution and of options.

Inspect and assess the building for:

- Structural integrity of the frame and foundation
- Contaminated soil (e.g., with lead, pesticides) surrounding the foundation
- Safety and serviceability of the electrical system
- Hazardous materials (e.g., lead, radon asbestos) in or on the building
- Rainwater, groundwater, or plumbing water leaks
- Rot or decay in framing
- Insect and pest damage and activity.

Deficiencies or hazards must be remediated prior to or as part of the project.

Locate any underground utilities (electric, gas, water, sewer) serving the building or passing near the foundation. Ensure these are protected during the retrofit project.

Identify any atmospherically vented (or naturally aspirated) combustion appliances in the home. With the exception of gas stoves and cooktops, combustion appliances—including fireplaces—should be direct-vented or direct exhaust-vented equipment. Atmospherically vented appliances must be replaced or reconfigured to direct-vented or direct exhaust-vented operation prior to or as part of the project.

Verify that all kitchen and bathroom exhausts are vented to the exterior of the building. Source control ventilation deficiencies must be corrected either prior to or as part of the project.

If the home lacks a ventilation system meeting the requirements of 2012 IRC, Section M1507.3, a ventilation system meeting this requirement must be installed either prior to or as part of the project.

4.3.4 Implementation Risks

Construction and renovation work entails inherent risks to workers. All applicable safety procedures must be followed.

Implementation risks specific to mineral fiber insulation board retrofit derive from the fibrous nature of the material. All workers handling or cutting material should:

1. Wear protective clothing and avoid exposed skin.
2. Wear goggles or similar enclosed eye protection.
3. Wear gloves that are impermeable to fibers.
4. Use tight-fitting dust masks to provide appropriate protection from airborne fibers.
5. Refer to material safety data sheets and manufacturer instructions for safe handling and exposure.

4.3.5 Installation Procedure

0. Locate underground utilities. Ensure these are protected throughout the project.

Locate utilities serving the building or passing near the foundation. Implement measures to protect these throughout the project.

STOP! Do not proceed if underground utilities are not located.

1. Excavate the perimeter.

Excavate to a depth of at least 2 ft below grade and 4 ft from the foundation wall. The bottom of excavation must slope at least 5% away from the foundation. For an insulated ground roof/foundation skirt, the depth of the excavation must also accommodate a clean aggregate layer and the insulation thickness.

The base of the excavation furthest from the foundation should be shaped and graded to allow the ground roofing material to form a trough for the drainpipe that is sloped to the drain outlet.

2. Install a metal closure and transition flashing.

Install a continuous metal closure and transition flashing at the top of the foundation wall. This must be sealed to the foundation wall with bituminous flashing membrane and sealant. Use

Ensuring Success

Significant retrofit of building enclosure components will change the dynamics of water, air, vapor, and heat flow within the home. To ensure that these changing dynamics do not have negative ramifications for health and safety or for building durability, the following conditions must be met either prior to or as part of the project.

- Combustion safety—All non-cooking appliances, including fireplaces, direct-vented or direct exhaust-vented appliances.
- Ventilation—Whole-house ventilation meeting the requirements of 2012 IRC, Section M1507.3 is installed and operational.

The following is also recommended:

- Soil gas control system—An active or passive soil gas control system installed and operational.

primer to ensure robust adhesion of bituminous flashing membrane. Seal lapped seams in the metal closure and transition flashing with bituminous membrane flashing or bituminous sealant.

3. Install an insulated ground roof/foundation skirt.

Where an insulated ground roof/foundation skirt is recommended or otherwise desired, place a capillary break of clean aggregate at the bottom of the excavation. Ensure that the surface of the aggregate slopes away from the foundation at 5% minimum. Place rigid insulation board over the aggregate and extending from the foundation wall to at least 3 ft from the foundation wall. The rigid insulation can be temporarily held in place with stakes at the bottom edge of the insulation boards.

The insulation material used in this application must be a rigid insulation board that is non-moisture sensitive. XPS and foamed glass rigid insulation meet these requirements. Even with the non-moisture-sensitive insulation material, it is important to provide capillary protection because sustained exposure to ground moisture could lead to moisture absorption and degradation in the insulation.

4. Install rubber roofing.

Place rubber roofing or similar material across the bottom of the excavation or on top of the rigid insulation and secure to the foundation with a retaining bar. Seams in the roofing material should be lapped at least 8 in.

5. Install a drainpipe.

Install a perforated drainpipe at the low end of the ground roof/foundation skirt. Slope the drainpipe to a storm water collection system or to a daylight outlet. Wrap the drainpipe in clean aggregate and filter fabric.

6. Install mineral fiber insulation board.

Install mineral fiber insulation board in multiple layers to a thickness as required to meet the thermal performance target for the foundation wall. The first layer installed against the foundation wall should be continuous with joints between insulation board pieces butted tight. Furring strips of plastic or preservative material (e.g., 1 in. decking ripped to width) is installed over the continuous insulation layer. Furring strips are fastened to the foundation wall using masonry fasteners. Mineral fiber insulation board with a thickness matching that of the furring strips is in filled between the furring strips. Additional layers of mineral fiber insulation board can be installed over the furring strip layer as needed or desired.

7. Install a protective finish.

Install an impact-resistant, non-ultraviolet-sensitive, non-moisture-sensitive finish over the mineral fiber insulation board from the top of the insulation to the level of finished grade. Examples of suitable protective finishes include brake-formed aluminum coil stock and cement stucco parge coat over cement backer board. The protective finish can be fastened to the furring inset in the second layer of mineral fiber insulation board.

The mineral fiber exterior foundation insulation does not need to be protected below grade. Certain protective finish materials such as stucco are not appropriate for ground contact and, therefore, are best terminated within the thickness of the drip trench and above the top of the backfill material.

8. Backfill with free-draining material.

The excavation should be backfilled to within 4 in. of finished grade with free-draining material. Separate free draining material from the soil with filter fabric.

9. Install a drip trench and finished grade.

Install a drip trench of clean stone that extends from the foundation wall finish past the drip line of the roof. The drip trench should be separated from the surrounding soil and backfill with landscape edging (at the side) and durable filter fabric. The drip trench serves two important functions: (1) it serves as a capillary break between the soil and the above-grade foundation retrofit assembly; and (2) it dissipates the energy of falling rain or roof runoff, thereby limiting splash-back. The drip trench may also serve an aesthetic landscape design purpose.

Finished grade should be sloped away from the foundation at a 5% or greater slope.

4.3.6 High Performance Mineral Fiber Retrofit Details

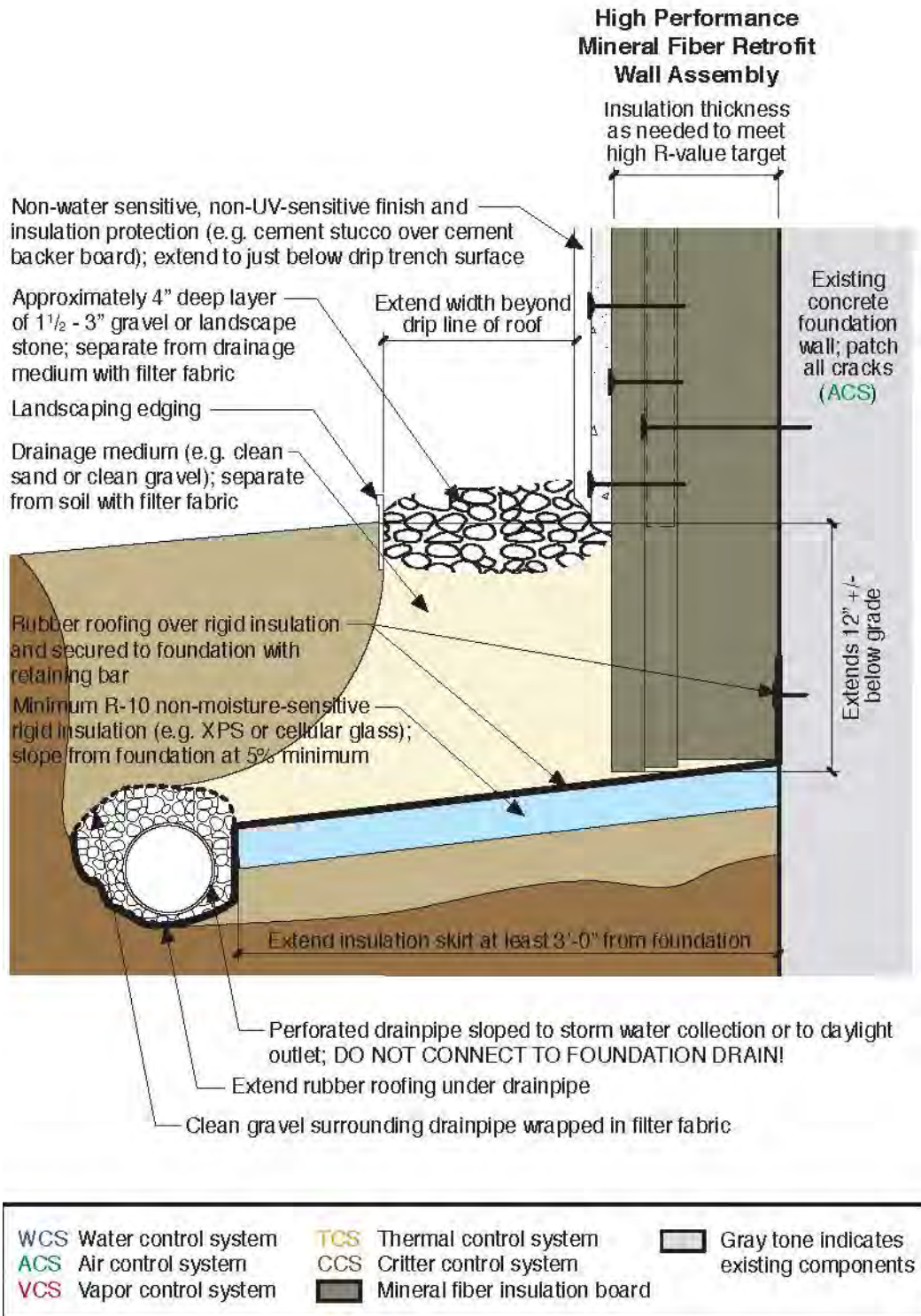
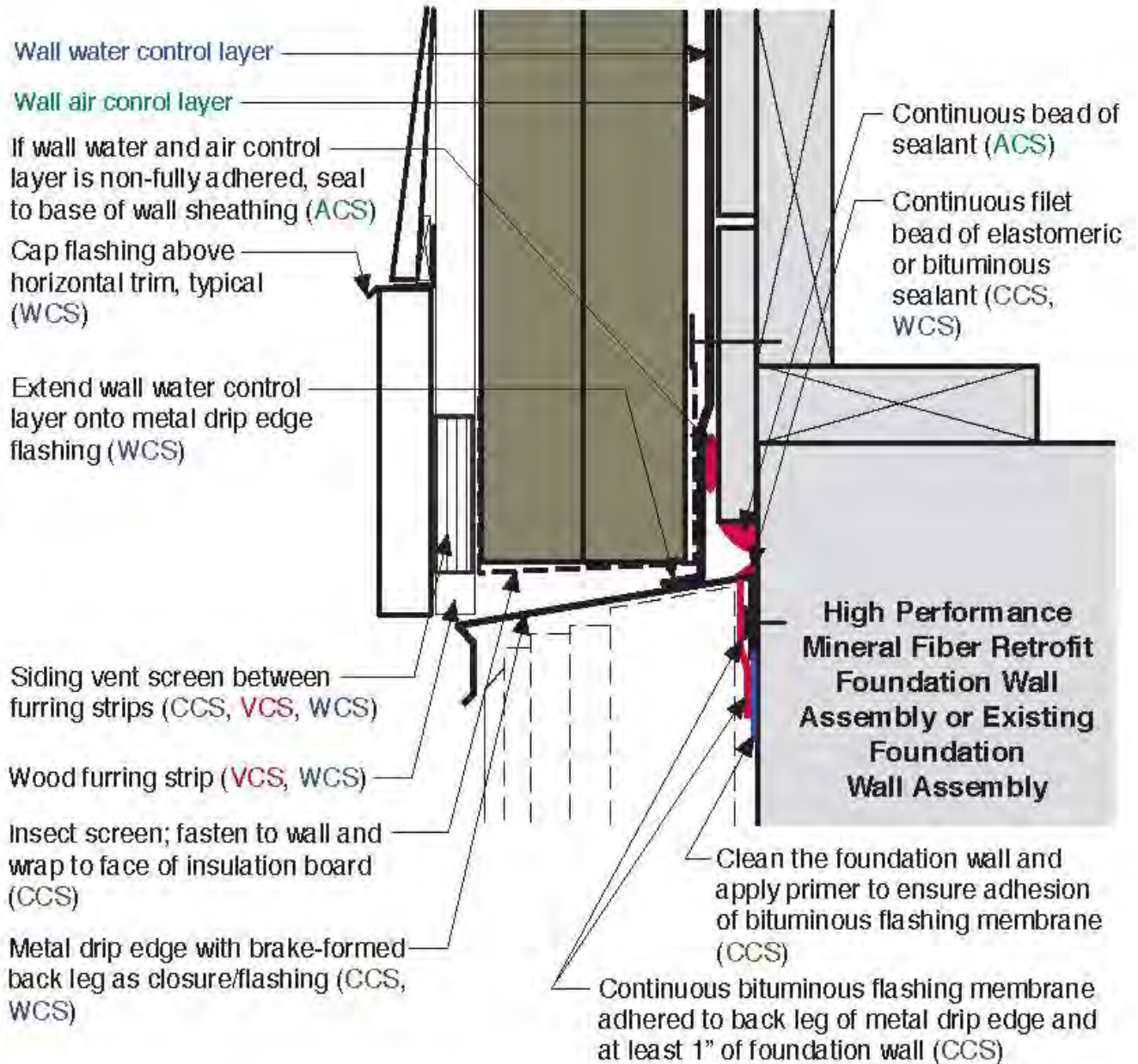

Figure 68. Schematic detail for insulated ground roof/foundation skirt with a high performance mineral fiber retrofit foundation wall assembly

High Performance Mineral Fiber Retrofit Wall Assembly



WCS Water control system	TCS Thermal control system	Gray tone indicates existing components
ACS Air control system	CCS Critter control system	
VCS Vapor control system	Mineral fiber insulation board	

Figure 69. Schematic detail for transition from a high performance mineral fiber retrofit wall assembly to a top of high performance mineral fiber retrofit foundation wall assembly showing how the metal closure/transition flashing is secured and sealed to the foundation wall.

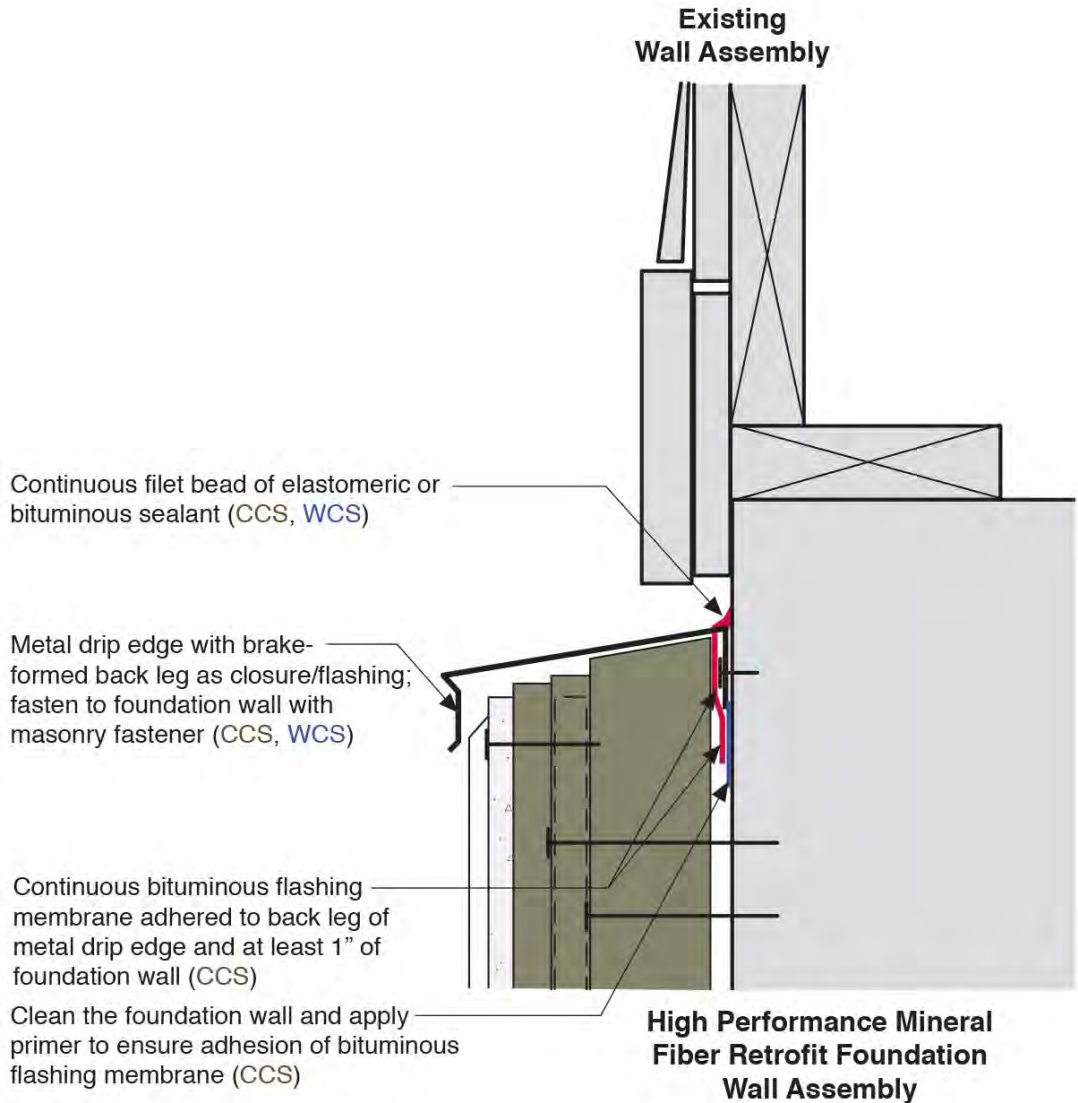

WCS Water control system	TCS Thermal control system	Gray tone indicates existing components
ACS Air control system	CCS Critter control system	
VCS Vapor control system	Mineral fiber insulation board	

Figure 70. Schematic detail for transition from a non-retrofit wall assembly to a top of high performance mineral fiber retrofit foundation wall assembly showing how the metal closure/transition flashing is secured and sealed to the foundation wall.

References

- Baker, P. (2012). *External Insulation of Masonry Walls and Wood Framed Walls*. RR-1204. Prepared by Building Science Corporation for the U.S. Department of Energy, Building America Program. Accessed November 3, 2014: http://apps1.eere.energy.gov/buildings/publications/pdfs/building_america/insulation_masonry_woodframed_walls.pdf.
- BSC (2010). *Cold Climate: Bedford Farmhouse High Performance Retrofit Prototype*. Prepared by Building Science Corporation for the U.S. Department of Energy, Building America Program. Accessed November 3, 2014: http://apps1.eere.energy.gov/buildings/publications/pdfs/building_america/bedford_farmhouse_case_study.pdf.
- Cowan, S.; Walsh, P. (2013). "Installing Roxul Mineral Wool on Exterior Walls." *Green Building Advisor, Guest Blog*. Accessed May 21, 2014: www.greenbuildingadvisor.com/blogs/dept/guest-blogs/installing-roxul-mineral-wool-exterior-walls.
- Dérome, D.; Karagiozis, A.; Carmeliet, J. (2010). The Nature, Significance and Control of Solar-Driven Water Vapor Diffusion in Wall Systems—Synthesis of Research Project, *ASHRAE Research Project RP-1235*.
- Gates, C.; Neuhauser, K. (2013). *Evaluation of Early Performance Results for Massachusetts Homes in the National Grid Pilot Deep Energy Retrofit Program*. Prepared by Building Science Corporation for the U.S. Department of Energy, Building America Program. Accessed November 3, 2014: http://apps1.eere.energy.gov/buildings/publications/pdfs/building_america/national_grid_pilot_evaluation.pdf.
- Gates, C.; Neuhauser, K. (2014). *Performance Results for Massachusetts & Rhode Island DER Pilot Community*. Prepared by Building Science Corporation for the U.S. Department of Energy, Building America Program. Accessed November 3, 2014: www.buildingscience.com/documents/bareports/ba-1401-performance-results-massachusetts-rhode-island-der-pilot-community.
- Holladay, M. (2011). "Musings of an Energy Nerd: Installing Mineral Wool Insulation Over Exterior Wall Sheathing." *Green Building Advisor*. Accessed April 2014: www.greenbuildingadvisor.com/blogs/dept/musings/installing-mineral-wool-insulation-over-exterior-wall-sheathing.
- Lepage, R.; Lstiburek, J. (2012). *Moisture Durability with Vapor Permeable Insulating Sheathing*. Prepared by Building Science Corporation for the U.S. Department of Energy, Building America Program. Accessed November 3, 2014: http://apps1.eere.energy.gov/buildings/publications/pdfs/building_america/moisture_durability_insulating_sheathing.pdf.
- Lepage, R.; Schumacher, C.; Lukachko, A. (2013). *Moisture Management for High R-Value Walls*. Prepared by Building Science Corporation for the US Department of Energy, Building America Program. Accessed November 3, 2014: http://apps1.eere.energy.gov/buildings/publications/pdfs/building_america/moisture_management_high_rwalls.pdf.

- Lstiburek, J. (2011). "BSD-106 Understanding Vapor Barriers." Accessed November 3, 2014: www.buildingscience.com/documents/digests/bsd-106-understanding-vapor-barriers/?searchterm=BSD-106.
- Lstiburek, J. (2010). "Mind the Gap. Eh!" *ASHRAE Journal*. Atlanta, GA: American Society of Heating, Refrigerating and Air Conditioning Engineers.
- Lstiburek, J. (2013a). "Rocks Don't Burn." *ASHRAE Journal*. Atlanta, GA: American Society of Heating, Refrigerating and Air Conditioning Engineers.
- Lstiburek, J. (2013b). "Joni Mitchell, Water and Walls." *ASHRAE Journal*. Atlanta, GA: American Society of Heating, Refrigerating and Air Conditioning Engineers.
- Neuhauser, K. (2011). *National Grid Deep Energy Retrofit Pilot*. RR-1111. Prepared by Building Science Corporation for the U.S. Department of Energy, Building America Program. Accessed November 3, 2014: http://apps1.eere.energy.gov/buildings/publications/pdfs/building_america/national_grid_retrofit.pdf.
- Pettit, B. 2009. Deep Energy Retrofit of a Sears Roebuck House: A Home for the Next 100 Years. High Performing Buildings, Vol. 2, Spring 2009.
- Pettit, B.; Neuhauser, K.; Gates, C. (2013). *Mass Save Deep Energy Retrofit Builder Guide*. Produced by Building Science Corporation (BSC) for the MassSave Energy Efficiency Program Administrators. Accessed November 3, 2014: <https://www1.nationalgridus.com/DeepEnergyRetrofit-MA-RES>.
- Smegal, J.; Straube, J. (2011). *Hygrothermal Analysis of Exterior Rockwool Insulation*. Prepared by Building Science Corporation for Walsh Construction, Co. Portland, OR. Accessed November 3, 2014: www.buildingscience.com/documents/reports/rr-1104-hygrothermal-analysis-exterior-rockwool-insulation/view.
- Straube, John (2011). "BSD-163: Controlling Cold-Weather Condensation Using Insulation." Building Science Corporation. Accessed May 21, 2014: www.buildingscience.com/documents/digests/bsd-controlling-cold-weather-condensation-using-insulation/.
- Straube, John (2010). "RR-1005: Building America Special Research Project: High-R Value Enclosures for High Performance Residential Buildings in All Climate Zones." Building Science Corporation. Accessed August 27, 2013: www.buildingscience.com/documents/reports/rr-1005-building-america-high-r-value-high-performance-residential-buildings-all-climate-zones/view.
- Ueno, K. (2010). *Residential Exterior Wall Superinsulation Retrofit Details and Analysis*. RR-1012. Prepared for the proceedings of Thermal Performance of Exterior Envelopes of Whole Buildings XI International Conference. Accessed March 4, 2014: www.buildingscience.com/documents/confpapers/cp-1012-residential-exterior-wall-superinsulation-retrofit.
- Wilson, A. (2013). "Mineral Wool Boardstock Insulation Gaining Ground in the Homebuilding Word." *Energy Solutions*, May 15. BuildingGreen.com. Brattleboro, VT.

U.S. DEPARTMENT OF
ENERGY | Energy Efficiency &
Renewable Energy

DOE/GO-102015-4555 • January 2015

BA-1502: Measure Guideline—Three High Performance Mineral Fiber Retrofit Solutions

About this Report

This report was prepared with the cooperation of the U.S. Department of Energy's Building America Program.

Direct all correspondence to: Building Science Corporation, 3 Lan Drive, Suite 102, Westford, MA 01886.

Limits of Liability and Disclaimer of Warranty:

Building Science documents are intended for professionals. The author and the publisher of this article have used their best efforts to provide accurate and authoritative information in regard to the subject matter covered. The author and publisher make no warranty of any kind, expressed or implied, with regard to the information contained in this article.

The information presented in this article must be used with care by professionals who understand the implications of what they are doing. If professional advice or other expert assistance is required, the services of a competent professional shall be sought. The author and publisher shall not be liable in the event of incidental or consequential damages in connection with, or arising from, the use of the information contained within this Building Science document.