

Revised January 2007



## Building Science Corporation

*Architecture and Building Science*

70 Main Street

Westford, MA 01886

P: 978.589.5100

F: 978.589.5103

[www.buildingscience.com](http://www.buildingscience.com)

## Guide to Insulating Sheathing



## Table of Contents

<b>Introduction</b> .....	<b>3</b>
<b>Background</b> .....	<b>4</b>
<b>Material Properties</b> .....	<b>6</b>
Types of Foam .....	6
<i>Thermoplastics</i> .....	6
<i>Thermosets</i> .....	6
R-value .....	7
Permeance .....	7
Durability .....	8
<b>Technical Concepts</b> .....	<b>9</b>
Additional Thermal Resistance .....	9
Rain Water Management .....	12
Vapor Management .....	14
Condensation Resistance .....	15
<b>Design and Construction</b> .....	<b>20</b>
General Installation .....	20
Cladding Attachment .....	21
Roof Connection .....	21
Foundations Connection .....	22
Window installation .....	24
<b>Related Concepts</b> .....	<b>28</b>
Advanced Framing .....	28
Cross Bracing and Inset Shear Panels .....	29

## Introduction

Residential housing design continues to move towards the development of high performance sustainable building systems. To be sustainable, a building must not only be efficient and durable but also economically viable. From this, new methods of enclosure design have been examined that provide high thermal performance and long-term durability but also take opportunities to reduce material use (including waste), simplify or integrate systems and details, and potentially reduce overall initial costs of construction.

One concept relating to enclosure design is to incorporate the use exterior foam insulating sheathing into the construction of the wall assembly. As with any building enclosure system, appropriate detailing for the management of water, vapor, and energy transfer are necessary.



## Background

As the desire to provide more thermally efficient enclosure assemblies increased so did the problems with moisture accumulation within building enclosure assemblies. Often the problems occurred due to new materials being introduced into the designs for specific purposes, without adequate understanding of all of their properties and the potential impacts on the assembly as a whole. Many enclosure failures occurred due to the lack of appreciation that products and materials have other properties than the ones that they are initially designed for.

Though these lessons were hard learned, we can now use this knowledge for our benefit. Through examining and understanding materials based on all of their properties (not just what they were initially created for), we can eliminate redundancies in enclosure design, making the systems simpler and more cost effective.

In cold climates the use of exterior rigid insulation sheathing boards has been a method of increasing thermal performance of the enclosure, as well as a means of reducing the condensation potential within exterior wall assemblies. This concept, while not new, has become more accepted in recent years and is being used in residential construction. While this method has proven to be effective, it was introduced as an addition to standard residential construction for a specific purpose. The base wall assembly generally remained unchanged, with other materials used for air sealing and water management.

The opportunity that presented itself was the integration of the exterior rigid insulation board into the enclosure assembly to act not only as insulation but also as the primary sheathing and, in certain areas, as the drainage plane and vapor control layer for the wall assembly. This system combined with advanced framing concepts can provide cost savings from the reduction of building materials used (fewer studs, the elimination of plywood or OSB sheathing, and housewraps), and the reduction of construction waste (incorporating standard construction product dimensions in the design of the building to minimize cutting).

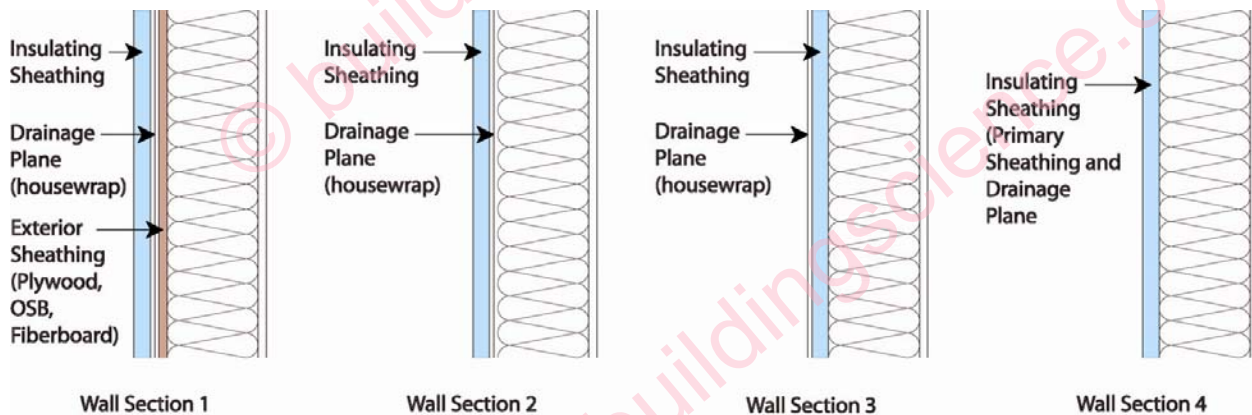



While the use of exterior insulation was initially used in cold climates, the benefits of the integrated system from increased thermal performance and reduced costs make it viable in other climate zones as well.

Still, proper understanding of the type of enclosure assemblies suitable for the overall climate zone in which the house is being constructed is critical. The choice of materials used will vary from climate zone to climate zone and the details for the water resistant barrier become more critical in areas of increased rainfall.

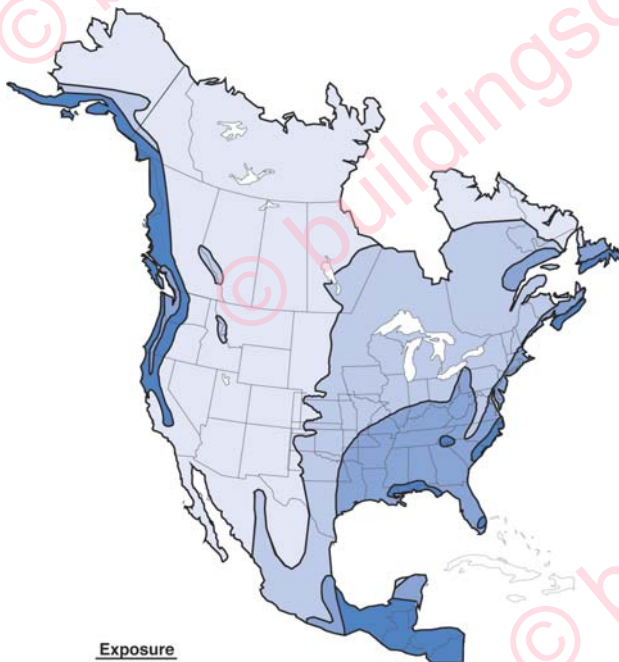

Exposure	
Extreme	Over 60" Ventilated <sup>1</sup> Rain Screen
High	40" - 60" Rain Screen/Vented <sup>2</sup> Cladding/Vented Drainage Space
Moderate	20" - 40" Drainage Plane/Drainage Space
Low	Under 20" Face Seal

This guide examines the application of insulating sheathing to exterior wall assemblies, from the technical conceptual design and benefits to the installation and interaction with other building systems.



## Material Properties

There are three main types of insulating sheathing currently being used in the industry: Expanded Polystyrene (EPS), Extruded Polystyrene (XPS), and Polyisocyanurate (Polyiso). Each of these products all has a different set of physical properties that will affect the dynamic of the wall assemblies in regards to the transmission and management of heat and moisture.

### *Types of Foam*

Insulating foam sheathings are split into two basic categories: 1) thermoplastics, 2) thermosets. Both EPS and XPS foams are thermoplastic foams, while Polyisocyanurate is a thermoset foam.

#### *Thermoplastics*

Thermoplastics are based on linear or slightly branched (non-cross linked) polymers. These foams have a definite melting range and will soften and melt at elevated temperatures. They are also more prone to react and degrade when in contact with some organic solvents as found in some paints, adhesives, and fuels. Therefore it is important to only use manufacturer approved compatible materials when using thermoplastic foams.

Of the thermoplastic foams, EPS and XPS are the most common used in the industry. Both products are based on polystyrene resin and are considered to be closed cell<sup>1</sup> rigid foams.

The manufacturing of EPS involves the expanding of polystyrene beads to fill a mold. The densities of EPS foam can be varied if desired. Increased density results in increased thermal resistance and compressive strength. The density of the product also affects the vapor transmission. While EPS is a closed cell foam (slow water vapor and air transmission through the cell walls), the gaps between the cells will still allow for moisture to pass through the matrix. With increased density, these spaces are reduced and the ability of the foam to allow water transmission is reduced.

XPS foams are formed by mixing molten polystyrene with a blowing agent at the correct time, at an elevated temperature, and at an elevated pressure and then extruding the foam through a die to the atmosphere. This creates a more regular cell structure providing for better strength properties and higher water resistance than EPS foams. The density of XPS foams can also be varied, allowing for increased compressive strength, however due to the more regular cell structure, this has little to no effect on the vapor transmission properties.

#### *Thermosets*

Thermoset plastics are based on cross linked polymers. This will allow thermoset plastics to be used for higher temperature applications as they do not usually exhibit a melting range and will instead char and burn. Thermoset foams are also generally more resistant to solvents and chemicals.

The most common thermoset foam on the market is polyisocyanurate. While traditional polyurethane foams were created by reacting isocyanate with polyol (and other blowing agents, catalysts, and surfactants) polyisocyanurate foams can theoretically be created with no polyol, using only isocyanate reacting with itself (and other blowing agents, catalysts, and surfactants). In general though, commercial polyisocyanurate foam used in the market is really polyurethane foam modified with polyisocyanurate or a "blend" of the two foams. The use of the blend increases the fire resistance while maintaining the thermal resistance and strength of the material.

---

<sup>1</sup> Closed cell foams, as apposed to open cell foams, have a higher resistance to air and vapor flow due to the cell walls being continuous.



## **R-value**

The thermal resistance of each of the products will vary. In general, EPS foam has the lowest R-value per inch, with XPS being slightly more efficient, and with Polyisocyanurate having the best R-value per inch. The R-value of EPS foams can be increased by increasing the density of the product, however, the more dense expanded foams are less common in the market. Typically EPS foam has a rated value of approximately R-4 per inch. XPS foams are pretty consistent with an R-value of approximately R-5 per inch.

While the thermal resistance of these thermoplastic foams is generally stable over the long term and therefore the initial R-value at the time of manufacturing will not change over time, polyisocyanurate foams are rated with a Long Term Thermal Resistance (LTTR) R-value representing a 15 year weighted R-value. This is in response to issues of thermal drift of the polyisocyanurate products. Thermal drift occurs due to the gasses produced during the forming of the foam. These gasses slowly diffuse out of the product over time and are replaced by air. Since these gasses also have more thermal resistance than air, the R-value of polyisocyanurate diminishes over time as the gasses diffuse out of the product. Facings on the insulation board, such as aluminum foil, will slow this process down as the diffusion can only occur out the edges of the product and not through the front and back faces. Most polyisocyanurate products have an LTTR R-value of R-6.5 per inch.

## **Permeance**

The permeance of the materials is important when examining the vapor control strategy of the wall assembly. Materials can be separated into four general classes based on their permeance:

Vapor impermeable	0.1 perms or less (Class I vapor retarder – considered a vapor barrier)
Vapor semi-impermeable	1.0 perms or less and greater than 0.1 perm (Class II vapor retarder)
Vapor semi-permeable	10 perms or less and greater than 1.0 perm (Class III vapor retarder)
Vapor permeable	greater than 10 perms (Not considered a vapor retarder)

For unfaced insulation, the permeability is a function of the material thickness. In general most product manufacturers list the permeance of the material based on a thickness of 1 inch. Increasing or decreasing the thickness of the material will affect the permeance. This can become an issue when using XPS foam insulation. 1 inch of XPS has a permeance of 1.1 perms (borderline Class II and Class III vapor retarder), increasing the thickness to 2 inches decreases the permeance to 0.55 perms (middle of the Class II vapor retarder). Therefore, 1 inch of XPS is considered to be vapor semi-permeable, while 2 inches is considered to be vapor semi-impermeable.

For faced rigid insulation boards (such as foil faced or glass fiber faced polyisocyanurate), the permeance of the facing is often much lower than the permeance of the polyisocyanurate and will govern the overall permeability of the sheathing board. For these products, the permeance will not change with increasing thickness.



**Table 1: Material Properties**

Expanded Polystyrene (EPS)	R-value/inch @ 75F (F.ft <sup>2</sup> .h/Btu)	Density (pcf)	Permeance (perms)	Water Absorption (% by volume)	Compressive Strength (psi)
	3.2	0.75	5.00	4.0	5
	<b>3.9</b>	<b>1.00</b>	<b>5.00</b>	<b>4.0</b>	<b>10</b>
	4.2	1.50	3.50	3.0	15
	4.4	2.00	2.00	2.0	25
<b>Extruded Polystyrene (XPS)</b>					
	4.6	1.20	1.10	0.3	15
	<b>5.0</b>	<b>1.30</b>	<b>1.10</b>	<b>0.3</b>	<b>15</b>
	<b>5.0</b>	<b>1.60</b>	<b>1.10</b>	<b>0.3</b>	<b>25</b>
	5.0	2.20	1.10	0.3	60
<b>Polyisocyanurate</b>					
unfaced*	6.0	1.60	2.77 - 4.49	-	-
foil faced	<b>6.5</b>	<b>2.0</b>	<b>0.03</b>	<b>1.0</b>	<b>25</b>
glass fiber faced	6.5	2.00	<1.0	1.0	25

## **Durability**

Insulating sheathings are generally fairly durable materials, however, they are not completely resistant to degradation. Polystyrene boards will degrade if left exposed to UV radiation for prolonged periods of time. The boards will discolor and a thin dusty film will form on the boards. Faced Polyisocyanurate is more resistant to UV degradation, however the unfaced polyisocyanurate boards are also susceptible to UV degradation.

EPS boards are less durable for excessive handling. The edges of the boards can break off as the bond between the expanded beads is not as strong as the matrix formed with XPS and polyisocyanurate. This can leave the boards with more rounded edges and decrease the thermal value at the joints between the boards. Careful cutting and handling is recommended when using EPS boards.

Most insulating sheathing boards are resistant to moisture, however problems with warping and cupping of the foil faced polyisocyanurate have occurred in the past when the boards have been left exposed to the weather for extended periods of time.

As a general rule, it is considered good practice to store the boards in a protected, covered, and dry location on site and to limit the amount of time the boards are left exposed before being covered over by the cladding material.





## Technical Concepts

### *Additional Thermal Resistance*

With rising utility cost, designing homes to be more energy efficient is increasing in importance. Part of the overall efficiency of a house is the thermal resistance of the various enclosure assemblies. Common residential construction use wall framing based on either 2x4 or 2x6 dimensional lumber with insulation installed in the stud cavities created by the framing members. With cavity insulation the overall thermal resistance can be varied somewhat, by using different types of insulation, varying the installation methods, and varying the stud spacing, but there is still a limit because of the depth of the stud cavity. Adding insulating sheathing to the exterior of the assembly is a simple method of increasing the overall thermal resistance of the wall assembly beyond that possible with cavity insulations and thereby increasing the overall efficiency of the house.

When examining the overall thermal resistance of the wall assembly, the effective R-value must be considered. A simple method than can be used to estimate the effective R-value of the cavity space is through using the isothermal planes method set out in Chapter 25 of the ASHRAE Fundamentals 2005. While this method is not as accurate as some other more sophisticated computer simulation models, it is a means to get a rough idea of the effective insulating value of an assembly. With the isothermal method, the effective R-value of the cavity assembly is a proportional sum of the various U-values of the different components based on material fractions.

$$U_{(cavity)} = U_{(studs)} \cdot F_{(studs)} + U_{(insulation)} \cdot F_{(insulation)}$$

Where:

$U_{(cavity)}$	= average U value of the insulation and studs
$U_{(studs)}$	= U value of wood framing
$U_{(insulation)}$	= U value of cavity insulation
$F_{(studs)}$	= fraction of area of studs, headers, and sill plates
$F_{(insulation)}$	= fraction of area of insulation

Therefore the effective R-value of the cavity can be expressed as:

$$R_{(cavity)} = 1/U_{(cavity)}$$

The overall R-value of the assembly is a sum of the thermal resistance of all of the components.

$$R_{(total)} = R_{(comp\ 1)} + R_{(comp\ 2)} + \dots + R_{(comp\ n)}$$

Where:

$R_{(total)}$	= total R-value of the assembly
$R_{(comp)}$	= individual effective R-value of each material layer

As an example the effective cavity insulation value and the total effective R-value for various assemblies were calculated. The fiberglass batt or blown cellulose may be rated as R-19, however due to the wood studs and other framing members the effective thermal resistance may be as much as 35% less than the rated cavity insulation, leaving an effective value of only R-12.5 for the cavity as seen in the calculations below.



Element	Cavity section R-value	Stud section R-value
Outside Air Film	0.17	0.17
1/2" Plywood	0.62	0.62
2x6 Wood Stud	n/a	5.83
5.5" Fiberglass Batt	19	n/a
1/2" Interior Gypsum	0.45	0.45
Interior Air Film	0.68	0.68
<b>Total</b>	<b>20.92</b>	<b>7.75</b>

The effective R-value of the following assembly with a 23% framing fraction is:

$$R_{(cavity)} = 1/[(0.77/19)+(0.23/5.83)]$$

$$R_{(cavity)} = 12.5$$

$$R_{(total)} = 0.17+0.62+12.5+0.45+0.68$$

$$R_{(total)} = 14.42$$

Insulating sheathing provides additional insulation to the house that is run continuous past the exterior face of the wood studs. Because of this the rated R-value for the insulating sheathing is very close to the effective R-value of the insulating sheathing in the assembly. With the lack of framing penetrating through the layer insulating sheathing, the whole R-value can be generally be used. This allows for large increases in the effective R-value of the assembly without substantially increasing the thickness of the wall.

Element	Cavity section R-value	Stud section R-value
Outside Air Film	0.17	0.17
1" Rigid Insulation	5	5
1/2" Plywood	0.62	0.62
2x6 Wood Stud	n/a	5.83
5.5" Fiberglass Batt	19	n/a
1/2" Interior Gypsum	0.45	0.45
Interior Air Film	0.68	0.68
<b>Total</b>	<b>25.92</b>	<b>12.75</b>

Incorporating 1 inch of rigid insulation into the design of the previous example wall assembly yields the following effective R-value for the assembly:

$$R_{(cavity)} = 1/[(0.77/19)+(0.23/5.83)]$$

$$R_{(cavity)} = 12.5$$

$$R_{(total)} = 0.17+5+0.62+12.5+0.45+0.68$$

$$R_{(total)} = 19.42$$

Adding one inch of insulating sheathing (R-5 for this example) will increase a 2x6 stud wall from an effective R-14.4 to an effective R-19.4. This represents an increase of 35% effective thermal resistance with only 15% increase in the overall wall thickness.



Element	Cavity	Stud
Outside Air Film	0.17	0.17
1" Rigid Insulation	5	5
2x6 Wood Stud	n/a	5.83
5.5" Fiberglass Batt	19	n/a
1/2" Interior Gypsum	0.45	0.45
Interior Air Film	0.68	0.68
<b>Total</b>	<b>25.3</b>	<b>12.13</b>

If the insulating sheathing is used as the primary sheathing (eliminating the plywood or OSB from the exterior)

$$R_{(cavity)} = 1/[(0.77/19)+(0.23/5.83)]$$

$$R_{(cavity)} = 12.5$$

$$R_{(total)} = 0.17+5+12.5+0.45+0.68$$

$$R_{(total)} = 18.80$$

With this configuration the wall thickness is only increased by 8% while the effective thermal resistance increases from R-14.4 to R-18.8, a 31% increase.

Element	Cavity section R-value	Stud section R-value
Outside Air Film	0.17	0.17
2" Rigid Insulation	10	10
2x6 Wood Stud	n/a	5.83
5.5" Fiberglass Batt	19	n/a
1/2" Interior Gypsum	0.45	0.45
Interior Air Film	0.68	0.68
<b>Total</b>	<b>30.3</b>	<b>17.13</b>

Incorporating 2 inches of rigid insulation into the design of the example wall assembly yields the following effective R-value for the assembly:

$$R_{(cavity)} = 1/[(0.77/19)+(0.23/5.83)]$$

$$R_{(cavity)} = 12.5$$

$$R_{(total)} = 0.17+10+12.5+0.45+0.68$$

$$R_{(total)} = 23.80$$

Adding two inches of rigid insulation to the exterior (R-10) will increase the effective R-value from R-14.4 to R-23.8. This represents an increase of 65% over the original effective R-value.

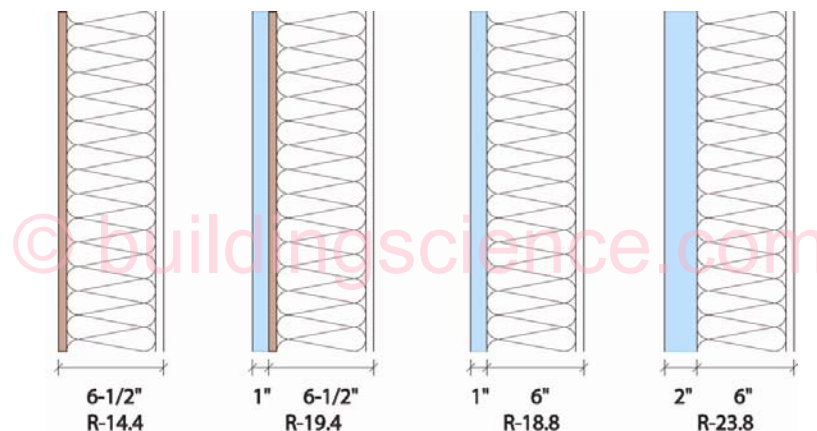

# Rain Water Management

For most climate zones the management of exterior rain water is the most critical aspect of the moisture management system of the building enclosure. The fundamental principle of water management is to drain the water downwards and outwards out of the building and away from the building. In order for the building and building assemblies to drain properly, detailing of the drainage plane must be carefully designed.

There are several options for creating a drainage plane in the wall assembly. The choice of which method to use is based on weighing the risks involved.

## Water Resistance



*As the water penetration resistance of the assembly increases, the risk of moisture problems decreases.*

## Moisture Tolerance of Assembly



*As the moisture tolerance of the materials that comprise the assembly increases (masonry and concrete vs. wood and steel) the risk of moisture related problems decreases.*

## Exposure



*As the exposure to rainfall increases, the risk of moisture related problems increases.*

## Rainfall



*As the amount of rainfall increases, the risk of moisture related problems increases.*

## Drying Potential



*As the ability of an assembly to dry increases due to the climate, design, or both, the risk of moisture related problems decreases.*

## Workmanship



*As the craftsmanship of the construction of the assemblies and their connection details increases, the risk of moisture related problems decreases.*



There are four strategies proposed for maintaining the continuity of the drainage plane with the incorporation of insulating sheathing to the exterior.

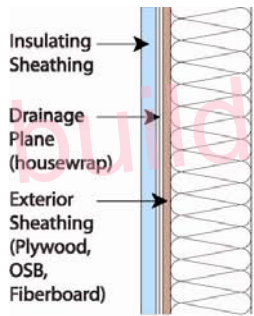

Wall Section 1

**Wall Section 1 - Insulating Sheathing and Housewrap over Plywood or OSB:** The first strategy involves installing the insulating sheathing over top of a layer of building paper or housewrap and wood sheathing. This is the most durable assembly proposed in this guide as the drainage plane material (building paper or house wrap) is supported by the plywood sheathing, and protected against wind loading and other environmental factors by the insulating sheathing. This type of assembly would be recommended in areas or high exposure and rainfall.

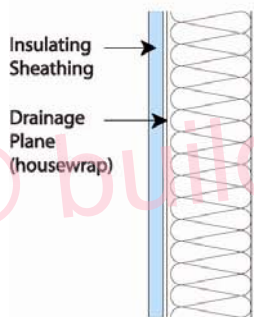

Wall Section 2

**Wall Section 2 - Insulation Sheathing and Housewrap over Wood Studs:** The next proposed strategy is to install the insulating sheathing overtop of a housewrap that is stretched over wood studs. In this configuration, the housewrap drainage plane is protected from exterior elements (excessive wind loading, and rain exposure). The type of assembly would work effectively in most rainfall zones, though potentially not in high exposure locations. With the lack of wood sheathing support on the exterior of the framing more care is required during the installation of the housewrap and insulating sheathing.

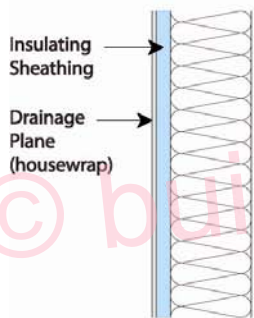

Wall Section 3

**Wall Section 3 - Housewrap installed over Insulating Sheathing and Wood Studs:** The third strategy would be to install the housewrap to the exterior of the insulating sheathing, essentially replacing the plywood or OSB in a traditional wall assembly with insulating sheathing. The housewrap is more exposed to exterior elements such as wind loading and moisture and may not be as durable as the other approaches. In addition the fasteners used to install the housewrap must be able to penetrate all the way through the insulating sheathing and into the wood studs beyond. This wall approach would function adequately in most rainfall zones.

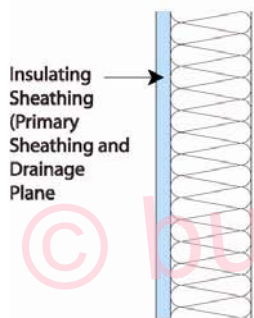

Wall Section 4

**Wall Section 4 - Insulating Sheathing as the Drainage Plane:** The final approach would be to use the insulating sheathing as the primary sheathing and drainage plane of the assembly. In order to achieve this all the vertical joints must be taped or sealed and special flashing details must be used. With some question as to the long term dimensional stability of insulating sheathing products, this approach is considered to be in the higher risk category and should only be used in areas with limited rainfall and exposure, where rain water management is not as critical.



## Vapor Management

The design of the vapor management system should attempt to allow maximum drying of the wall assembly from diffusion, while limiting the amount of moisture able to be driven into the assembly. Where possible, drying to both sides of the construction assembly is encouraged, however in some circumstances more stringent vapor control is required. As a general rule for standard framed construction, the vapor retarding layer should be placed to the interior of the assembly in cold climates (reducing the water vapor from the higher humidity interior air from diffusing into the assembly), while in hot humid climates, the vapor retarding layer should be placed to the exterior of the assembly (reducing the water vapor from the hot humid outside air from diffusing into the assembly).

Therefore, in a general sense, for cold climates it is preferable to use a more vapor permeable insulating sheathing (such as EPS and unfaced XPS) on the exterior and in hot humid climates, it is preferable to use a more vapor impermeable sheathing on the exterior of the assembly (such as foil faced polyisocyanurate and plastic film faced XPS).

For mixed humid climates, the system choices become more difficult as the assembly needs to be protected from wetting from both the interior as well as the exterior. The drying can be predominantly to the exterior, the interior, or in both directions in a flow through type assembly. Often these strategies need to be combined with other vapor management strategies such as building pressurization (or depressurization) and supplemental dehumidification. There is also a strategy to place the vapor control layer towards the middle of the assembly. This approach will be discussed in the next section on Condensation Resistance.

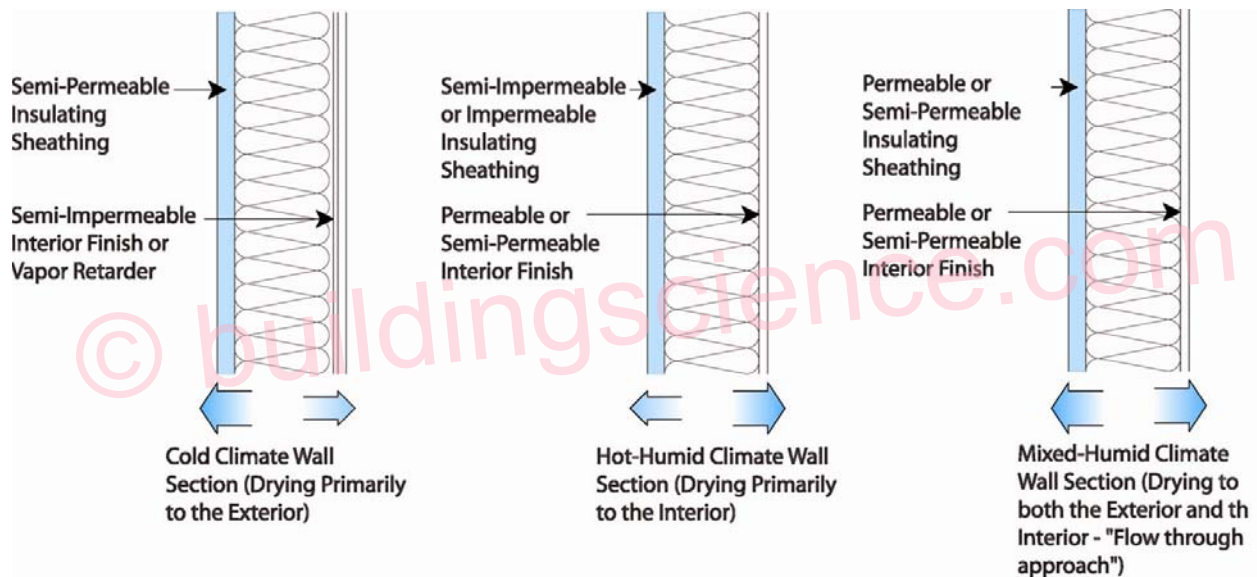

There are also some exceptions. With absorptive claddings such as brick veneer and stucco, a high inward vapor drive can occur due to solar radiation heating up the wet cladding and creating a high vapor pressure difference between the brick (or stucco) and the exterior and the brick (or stucco) and the interior. This vapor pressure differential will cause moisture to be driven into the assembly if there is not adequate vapor control on the exterior. For this reason, insulating sheathing that is installed behind a masonry veneer or stucco should be vapor semi-impermeable or it can be semi-permeable if combined with an impermeable or semi-impermeable membrane.



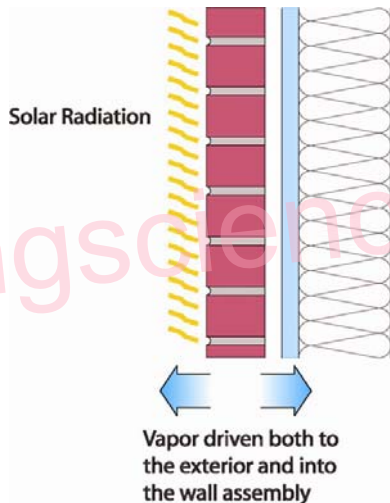

## Condensation Resistance

Condensation can occur when moisture laden air comes in contact with a material with a surface temperature below the dewpoint temperature of the air. In a cold climate wall assembly, this usually occurs at the interior face (or back side) of the exterior sheathing when moisture from the conditioned space penetrates into the wall assembly through vapor diffusion or air movement. The addition of insulating sheathing to the exterior of an assembly in colder climates can provide for some condensation resistance within the wall assembly as it will change the thermal gradient through the assembly.

The thermal gradient across an assembly describes how the temperature varies from one side of an assembly through to the other. The thermal gradient can be predicted by examining the individual proportion of thermal resistance provided by each component. Each different component will provide a percentage of the total thermal resistance of the assembly. Therefore, the change in temperature of any component is based on the percentage of thermal resistance provided by that component multiplied by the overall temperature difference across the assembly.

$$\Delta T_{(comp)} = R_{(comp)} / R_{(total)} \times (T_{(in)} - T_{(out)})$$

Where:

- $\Delta T_{(comp)}$  = temperature change across a component
- $R_{(comp)}$  = thermal resistance of the component
- $R_{(total)}$  = total thermal resistance of the assembly
- $T_{(in)}$  = interior temperature
- $T_{(out)}$  = exterior temperature

To determine the temperature at any given surface in the assembly, the individual temperature changes across each component in the assembly up to the desired surface is added to the exterior temperature.

$$T_{(surface)} = T_{(out)} + \Delta T_{(comp\ 1)} + \Delta T_{(comp\ 2)} + \dots + \Delta T_{(comp\ n)}$$

The example below examines the temperature of the inside surface of the exterior sheathing with an exterior temperature of 32F and an interior temperature of 70F. For the first section below, the temperature at the inside surface of the exterior sheathing would be calculated as:

$$\begin{aligned} T_{(surface)} &= T_{(out)} + \Delta T_{(exterior\ air\ film)} + \Delta T_{(plywood)} \\ T_{(surface)} &= 32 + [0.17/20.92 \times (68-32)] + [0.62/20.92 \times (68-32)] \\ T_{(surface)} &= 32 + [0.0081 \times 38] + [0.0296 \times 38] \\ T_{(surface)} &= 32 + 0.31 + 1.13 \\ T_{(surface)} &= 33.44\ F \end{aligned}$$



For the next two sections, the temperature of the inside surface of the exterior sheathing is 39.77 F and 44.74 F respectively.

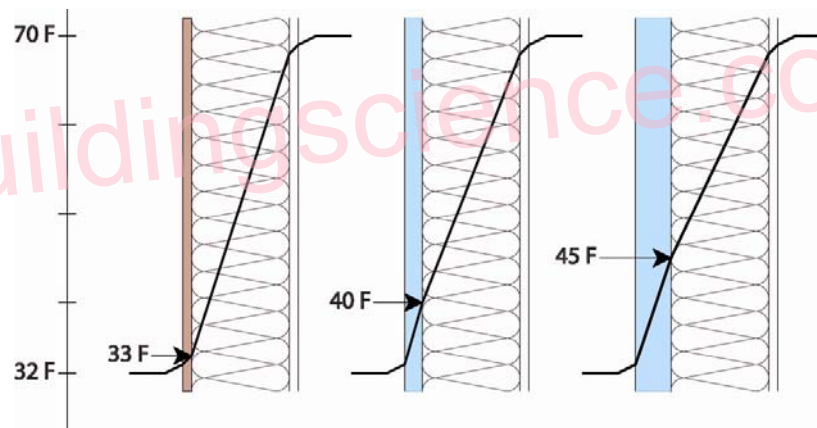

As it can be seen from the figure above, with the additional thermal resistance of the rigid board insulation material, the temperature of the inside face of the sheathing will be warmer in the winter months than with traditional wood sheathing alone. Since the surface temperature is warmer, there is less of a risk of condensation forming on the inside face. If the exterior wood sheathing is eliminated, the system becomes even more durable as insulation sheathings are resistant to water and will not degrade if a small amount of condensation does occur.

For this to be applied effectively, understanding the climate zone and the interior environmental conditions in which the assembly is being designed is very important. As an example, three different wall sections were examined in three different locations. In each example the interior conditions were set at 70 F and 35% Relative Humidity. Air under these conditions will have a dew point of approximately 40 F (determined from the psychrometric chart). Also, each assembly was assumed to have a vapor permeable interior finish or no effective interior air barrier layer allowing for the more humid interior air to come in contact with the interior face (condensing layer) of the exterior sheathing.

The three wall sections were analyzed for the Chicago, IL area with the exterior conditions based on the average monthly temperatures for a one year cycle. The first wall section, designed under the traditional approach with wood sheathing, is at risk of condensation accumulation on the back of the wood sheathing from the middle of November to the middle of March (this is shown by the segment of the temperature profile that drops below the dewpoint of 40 F for the interior air). With the addition of 1 inch of insulating sheathing, the time period of condensation potential time is now from the middle of December to the middle of February. The addition of 2 inches of insulating sheathing the temperature profile does not drop below the dewpoint temperature, and therefore no longer at risk. With 2 inches of insulating sheathing, the wall assembly would not require an interior vapor control layer or interior continuous air seal.





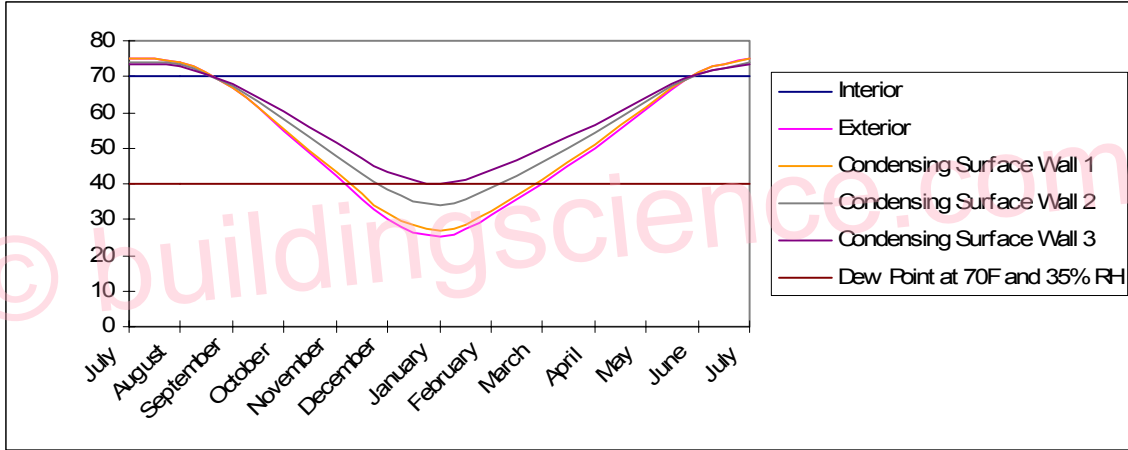

If the wall sections are moved to Minneapolis, MN exterior insulating is no longer adequate on it's own to manage the condensation resistance of the wall assembly. For each profile, an interior vapor control layer and air barrier would be required.

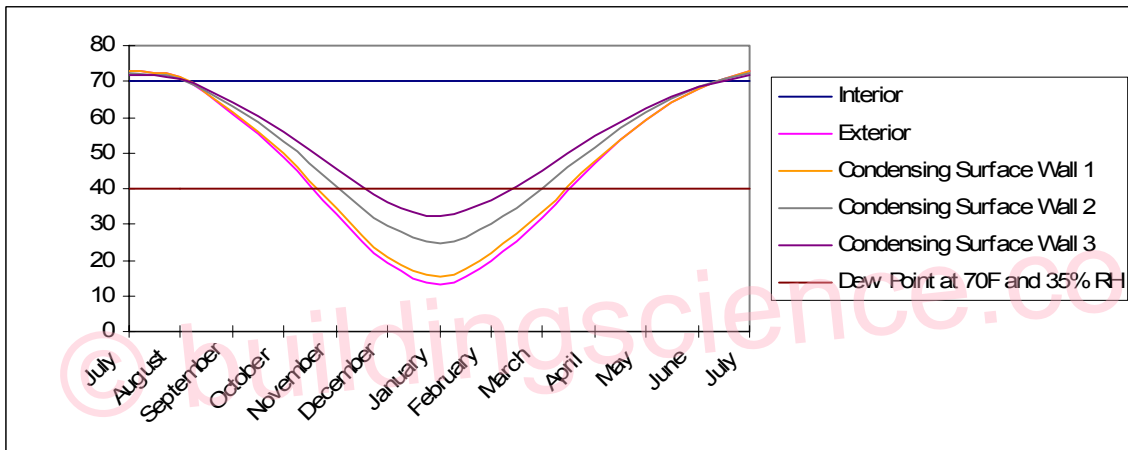

Conversely, if the profiles are moved to Seattle, WA, the exterior conditions are not cold enough to create problems with condensation even with the traditional approach (as long as the interior relative humidity is maintained below 35% RH).



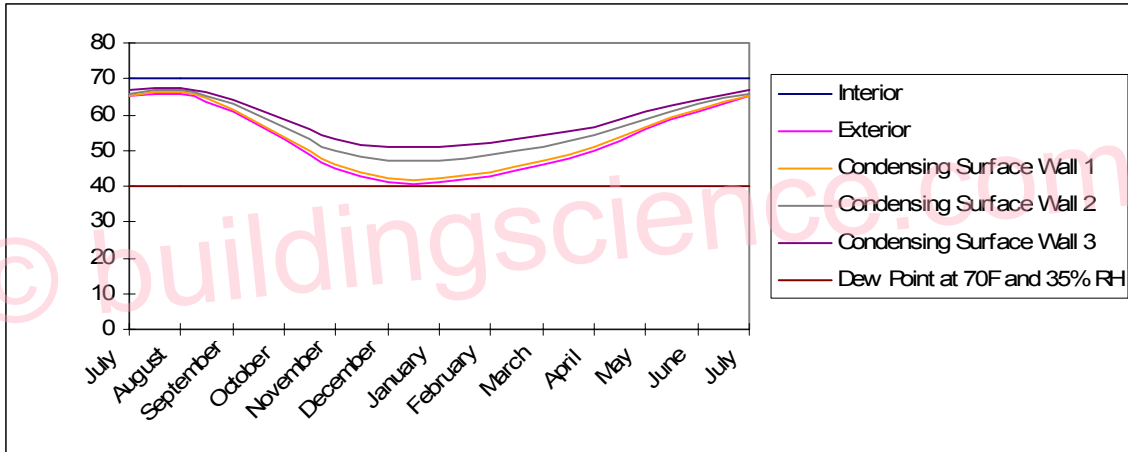

If the interior conditions change, the condensation potential will also change. Reexamining the Chicago, IL sections once again and varying the interior relative humidity demonstrates that 1 inch of insulating sheathing would be adequate if the relative humidity was kept below 25% (dewpoint of 32F), or that 2 inches of insulating sheathing would not be adequate if the interior relative humidity increases to 50% (dewpoint of 50F)

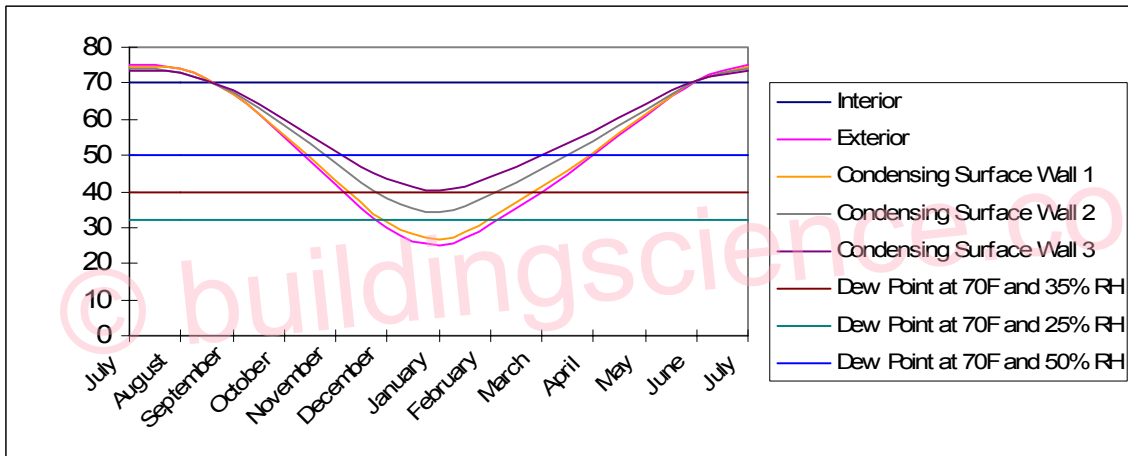

While the use of insulating sheathing can help to reduce the condensation potential, it is only a component in the overall design of the building enclosure assembly. The examples above were used to demonstrate how insulating sheathing can reduce the condensation potential in an assembly; however, design of the building enclosure will likely include other water, air, and vapor management strategies as well.

As mentioned earlier, in mixed humid climates, the thermal gradient approach can be used as part of the vapor management strategy. The use of impermeable insulating sheathing materials of adequate thickness to ensure that the dewpoint temperature is not reached within the assembly, will allow for the interior vapor control layer to be eliminated from the assembly (installing a vapor retarder on the interior would actually be detrimental to the system). With the impermeable or semi-impermeable nature of the



sheathing, the exterior face of the board would function as a vapor retarder during the cooling month, while the interior face of the insulating sheathing would function as a vapor retarder in the heating months. The air barrier for the system could also be installed to the interior or exterior of the assembly. This approach should also be combined with a slight positive interior pressure to limit the amount of infiltration of moist air during the cooling season as well as some interior moisture control to ensure that the interior RH does not exceed the maximum levels to prevent condensation on the interior surface of the exterior sheathing during the heating season.

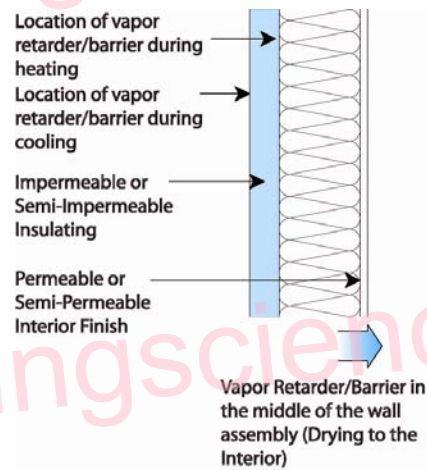

## Design and Construction

The following four wall sections are used as the basis for discussion for this section.

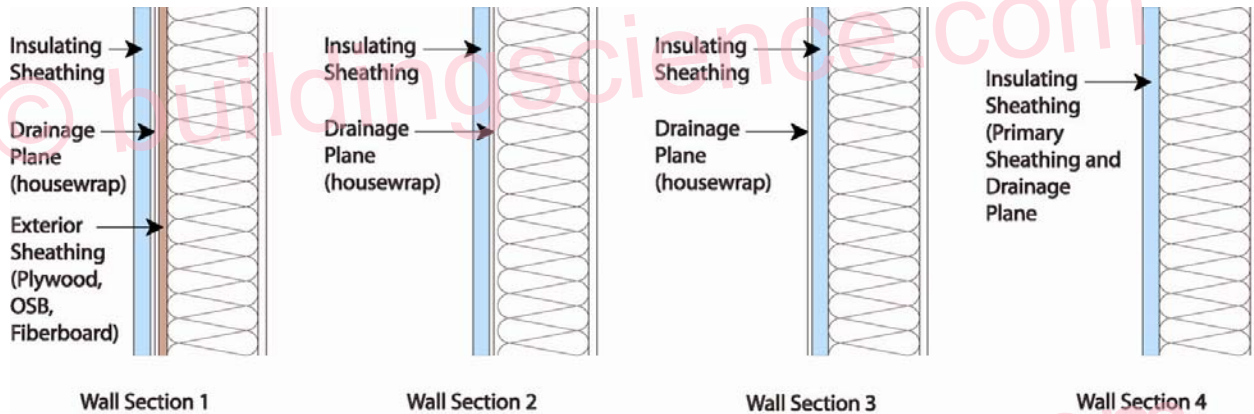

### General Installation

Insulating sheathing should be installed based on manufacturer's recommendations for fastener type and amount. It is recommended to layout the insulating sheathing such that vertical joints do not occur at the corners of window and door openings or over window heads if possible.

In Wall Section 1 and Wall Section 2 the primary drainage plane occurs behind the insulating sheathing. All water management details (flashing and window installation details) should be tied back to the plane of the housewrap. In these configurations, while the insulating sheathing is not officially considered to be part of the drainage system of the wall, it will provide some protection for the housewrap in preventing much of the exterior rain water that penetrates past the cladding from penetrating through to the actual drainage plane.

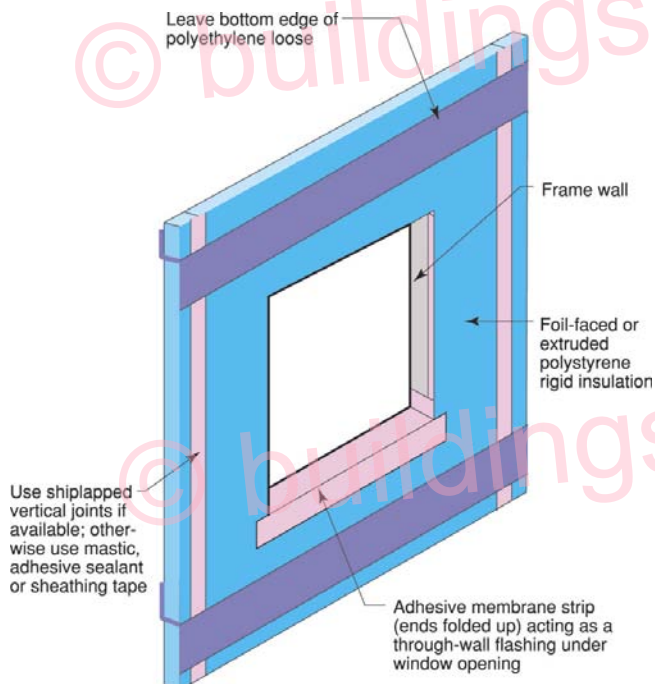

For Wall Section 3, the primary drainage plane is to the exterior of the insulating sheathing and more exposed to the elements. In this configuration the water management and window installation details are integrated into the housewrap at the exterior face of the insulating sheathing. Water management details would be the same as normal details of recommended good practice for wood sheathed house design.

Wall Section 4 requires some special detailing. All the joints between the insulation boards must be designed in such a way as to prevent water from penetrating past the exterior face of the insulation. Sealing or taping the vertical joints should be done and if possible, products that use shingle lapped or tongue and groove joints should be used. A polyethylene flashing is recommended to be installed at the horizontal joints in the system.



In order for the insulation sheathing to be used as a water resistive barrier, the vertical plane of the exterior face of the sheathing must be as continuous as possible. This is to prevent locations within the wall assembly where drainage could be blocked or where water might be held.

For added protecting, window head flashing and roof step flashings can be easily regletted into the face of the foam sheathing providing for better protection against flashing failure and reverse flashing problems. The reglette should only penetrate into the face of the sheathing and not all the way through the sheathing.

### ***Cladding Attachment***

For siding systems (wood, vinyl, and fiber cement) and masonry veneers, there is virtually no change from standard recommended practice for cladding attachment details. One of the only differences is that all fasteners must be installed through to the studs as insulating sheathing does not have adequate structural capacity both in shear and pull out strength.

For Wall Section 1 and Wall Section 2, cladding systems such as traditional hard coat stucco (including thin brick and manufactured stone veneer) and acrylic stucco can be directly applied to the insulation board. With these types of systems it is recommended to use drained insulation boards (ones with vertical grooves cut in the back) or to use a vertically textured (or profiled) housewrap, to ensure that there is a drainage space behind the rigid board.

For Wall Section 3 and Wall Section 4, traditional hard coat stucco (including thin brick and manufactured stone veneer) should NOT be installed without the addition of at least one layer of building paper or house wrap between the stucco renderings and the housewrap or drainage plane sheathing to act as a bond break.

### ***Roof Connection***

Popular roof construction types will vary from one region to another. Much of the country relies on sloped roof assemblies with eave overhangs. In other areas, flat roof construction is more common. The roof wall connection will vary therefore depending on the type of roof assembly used.

In sloped roof applications the insulating sheathing is installed up to the underside of the roof truss. If desired, the insulating sheathing can be notched around the roof trusses to act as a wind shield for the attic insulation.

For Wall Section 1 and Wall Section 2, at gable ends and parapets, the insulating sheathing is not required to extend to the full height of the construction since the drainage plane is maintained behind the insulation through the use of a housewrap. Due to this the insulating sheathing can be stopped at the top of the plane of attic insulation. However it may be convenient to extend the insulating sheathing the full height to simplify the cladding attachment at these areas. Otherwise alternative methods to fur out and support the cladding will be required.

Conversely, For Wall Section 3 and Wall Section 4, the continuity of the drainage plane must be maintained to the exterior of the insulating sheathing. For these wall sections often the simplest way to maintain the continuity of the drainage plane, is to install the insulating sheathing up to the top of the parapet or over the gable end. An alternative method for maintaining the drainage plane is to use a thin profile structural sheathing, furred out and installed so that it is in plane or proud of the insulating sheathing to maintain the continuity of the drainage plane.



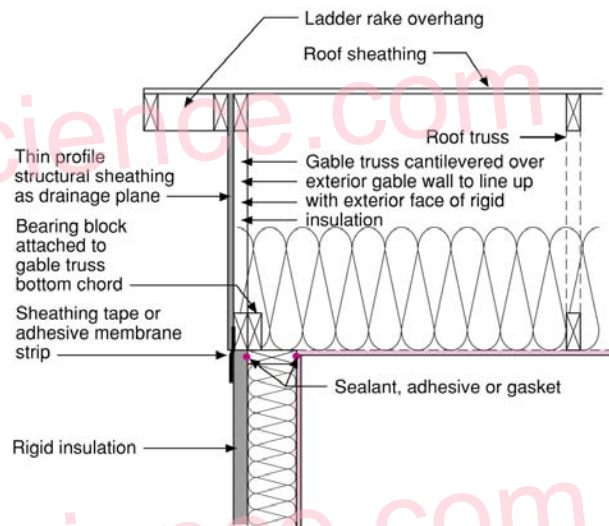
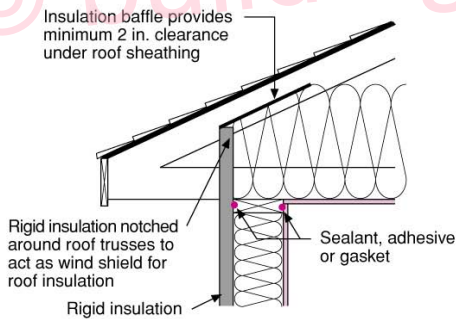
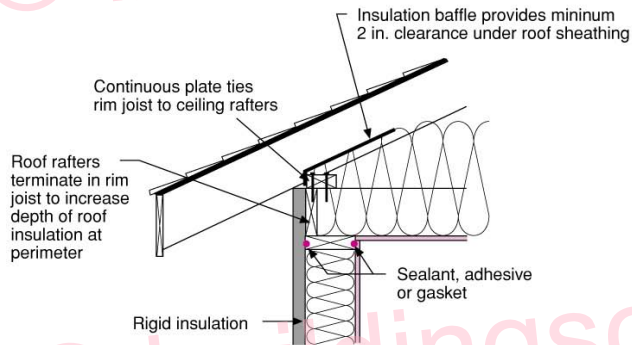
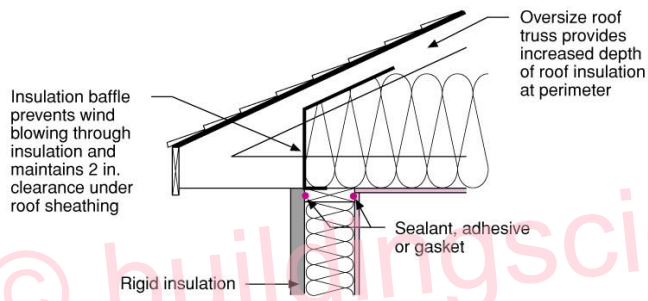

### Foundations Connection

The installation details for insulating sheathing at foundations are generally the same for all foundation types. The intention is to continue the sheathing past the top edge of the foundation or basement wall to create a shingle lap with the foundation. For walls with brick veneer, this may not be possible. In this situation, a seat should be cast into the top of the foundation wall so that the brick and the insulation sheathing terminate at a level below the bottom plate of the stud wall. This will allow a shingle lap joint to be created.



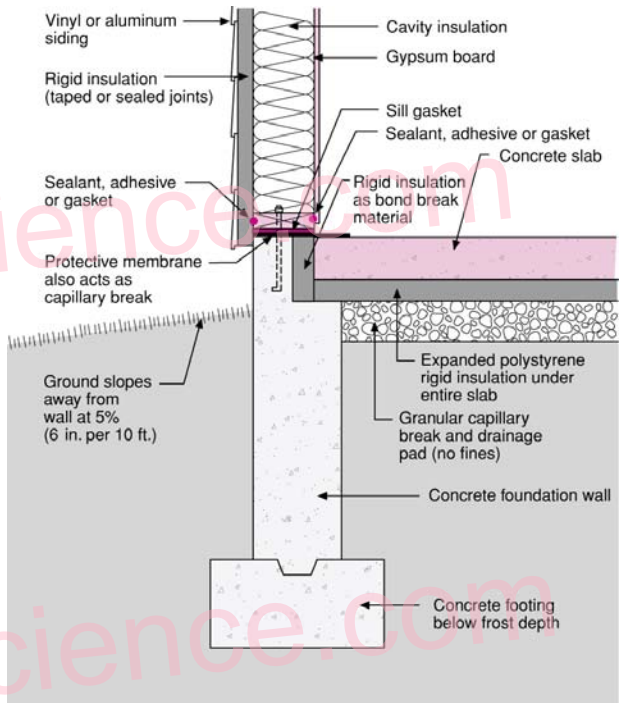
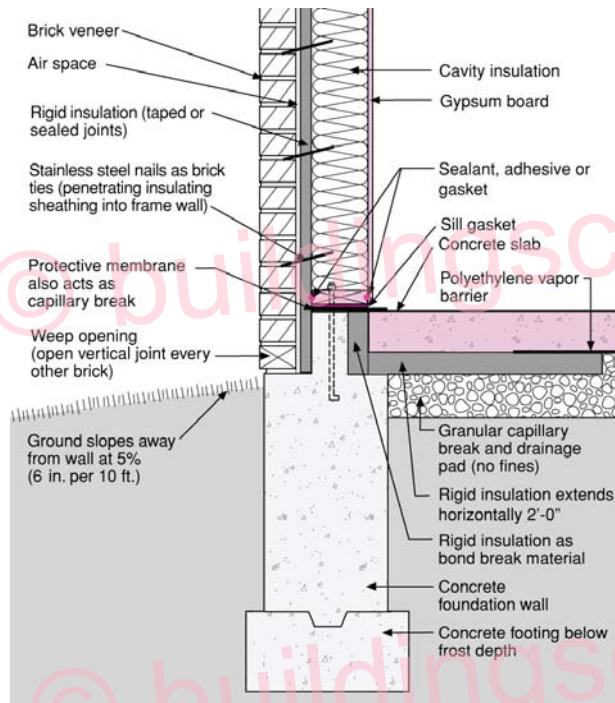

## Window installation

The following window installation sequence details is applicable to Wall Section 1 (Wall Section 2 details would be almost identical – with the elimination of wood sheathing behind the housewrap)

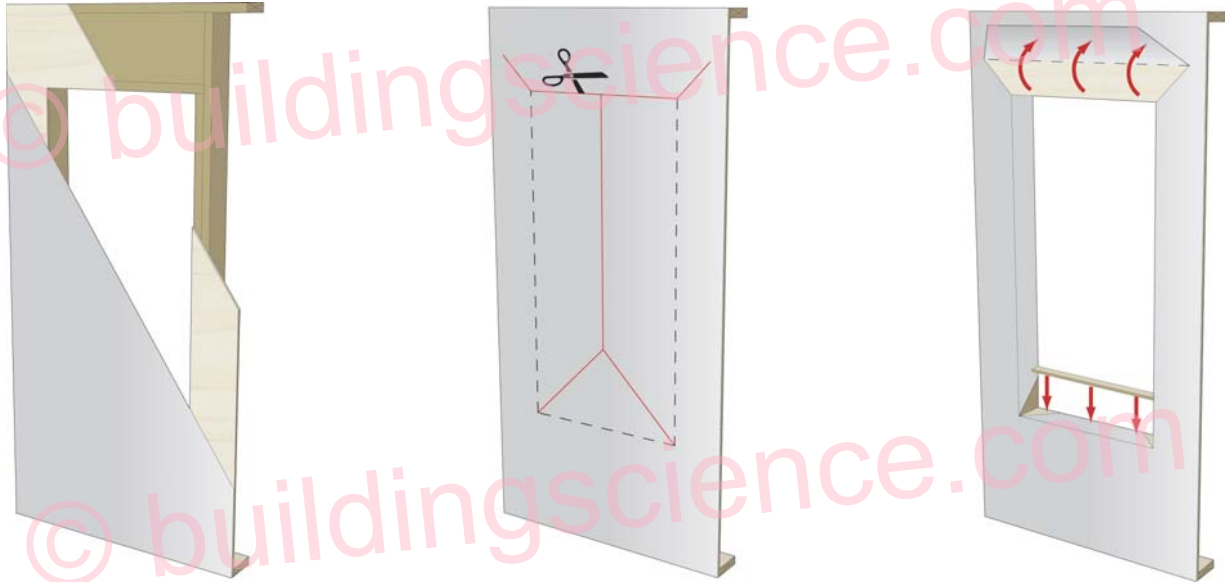

1. Wood frame wall with OSB and housewrap
2. Modified "I" cut in housewrap
3. Housewrap folded in at jambs and sill. Housewrap at head temporarily folded up or, alternatively, tucked under; Install backdam.

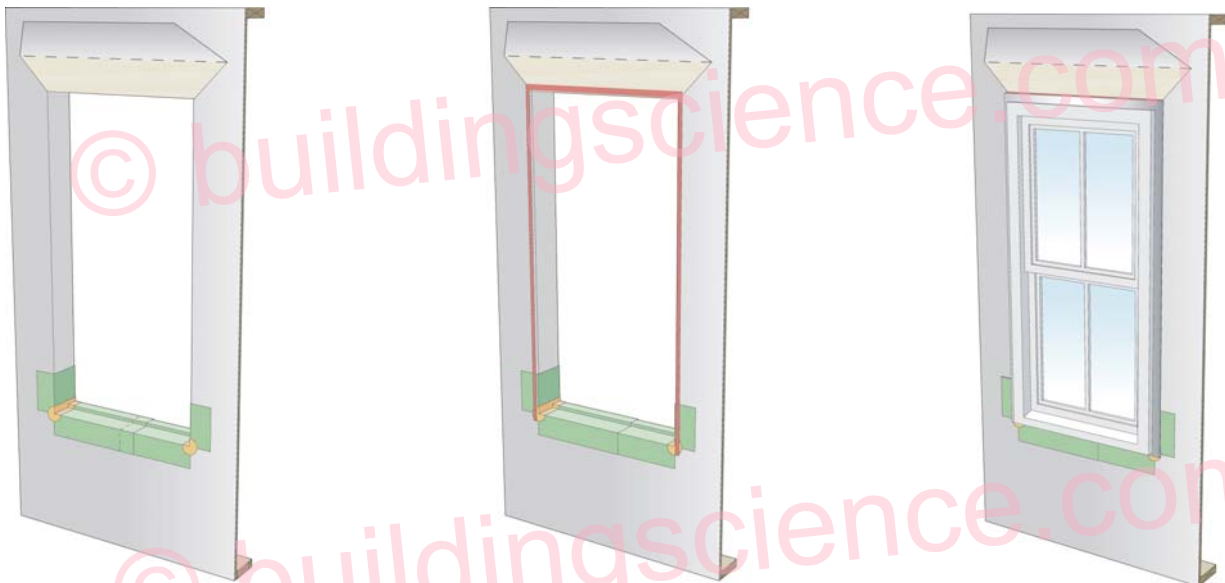

4. Install adhesive backed sill flashing and corner flashing patches at sill.
5. Apply sealant at jambs, head and sill. Alternatively, sealant can be applied to the back side of the nailing flange (sealants, housewraps, and flashings must be chemically compatible).
6. Install window plumb, level, and square as per manufacturer's instructions.







7. Install jamb flashing first; Install a drip cap (if applicable); Install head flashing.
8. Fold down head housewrap
9. Apply corner patches at head; Air seal window around the entire perimeter on the interior with sealant or non-expanding foam; Install foam sheathing over housewrap.



The following window installation sequence details are applicable to Wall Section 4 (Wall Section 3 details would be almost identical – addition of housewrap to the exterior of the insulating sheathing prior to window rough opening preparation)



1. Install foam sheathing on wood frame wall.
2. Install backdam.
3. Install first piece of adhesive backed sill flashing; apply second piece of adhesive backed sill flashing.



4. Install corner flashing patches at sill.
5. Install adhesive backed jamb flashings (jamb flashing adhered to foam and stapled to frame)
6. Apply sealant at jambs, head and sill. Alternatively, sealant can be applied to the back side of the nailing flange (sealants, housewraps, and flashings must be chemically compatible).





7. Install window plumb, level, and square as per manufacturer's instructions.
8. Install jamb flashing.
9. Install drip cap (if applicable); install head flashing; tape head flashing; air seal around the perimeter on the interior with sealant or low expanding foam.



## Related Concepts

### Advanced Framing

The use of advanced framing with insulation sheathing is another concept used to reduce the amount of materials in residential construction. The layout of the sheathing boards over the area of the wall framing should be done to minimize the amount of cutting of the material and construction waste created.

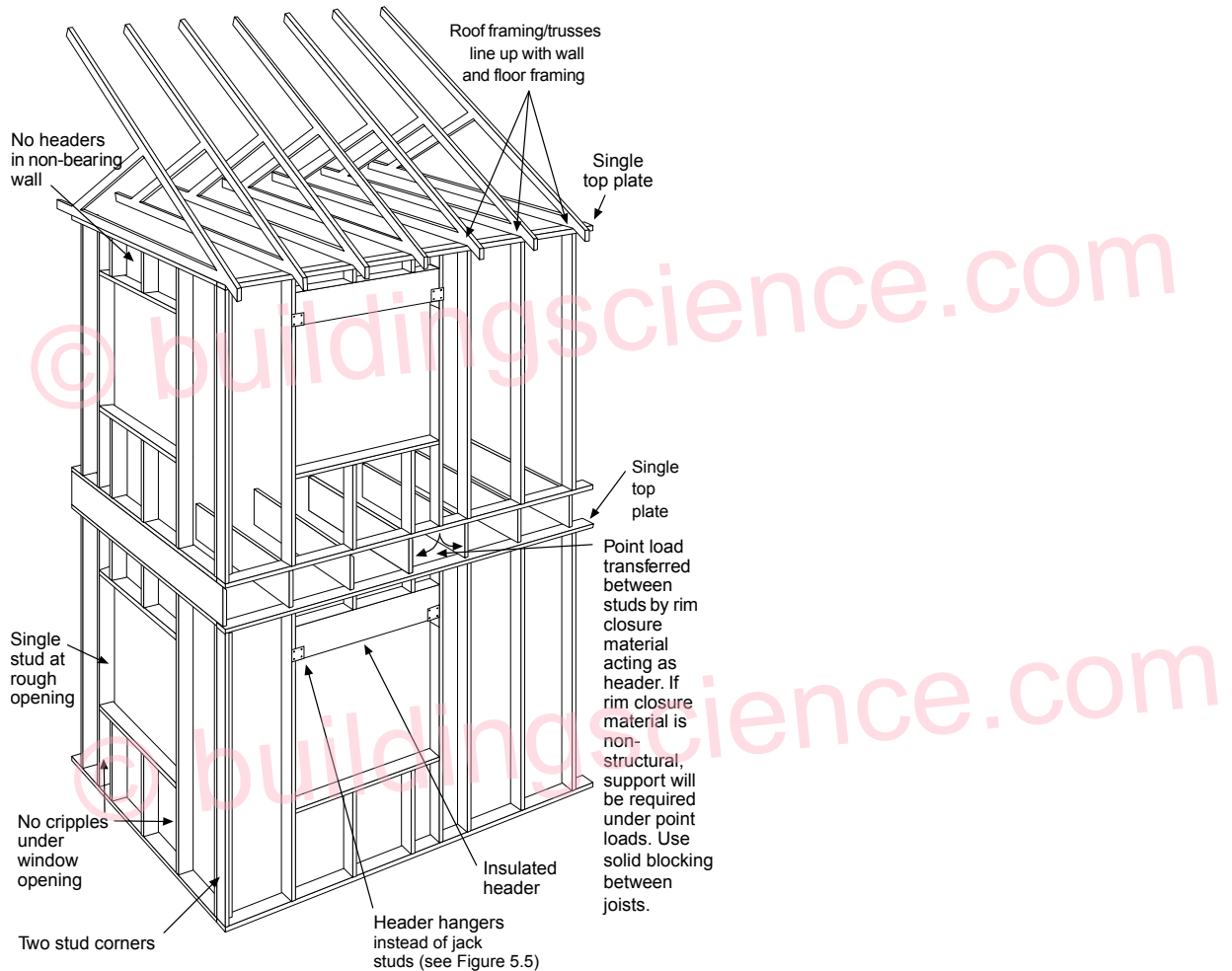

This will impact the effective thermal resistance of the wall assembly as well. Standard residential construction will end up with a framing fraction for the wall assemblies of around 23% of the wall area. With advanced framing this fraction can be reduced down to approximately 16% and sometimes even less. If we reexamine the techniques for calculating the effective R-value of the assembly as used in the Thermal Resistance section we obtain the following results.



Element	Cavity Section R-value	Stud Section R-value
Outside Air Film	0.17	0.17
1" Rigid Insulation	5	5
2x6 Wood Stud	n/a	5.83
5.5" Fiberglass Batt	19	n/a
1/2" Interior Gypsum	0.45	0.45
Interior Air Film	0.68	0.68
<b>Total</b>	<b>25.3</b>	<b>12.13</b>

The effective R-value of the following assembly with a 16% framing fraction is:

$$R_{(cavity)} = 1/[(0.84/19)+(0.16/5.83)]$$

$$R_{(cavity)} = 13.96$$

$$R_{(total)} = 0.17+0.62+13.96+0.45+0.68$$

$$R_{(total)} = 20.26$$

The same effective R-value with a 23% framing fraction yielded a total R-value of 18.80. This represents a 7.8% increase in thermal resistance for the entire assembly.

### Cross Bracing and Inset Shear Panels

In Wall Sections 2, 3 and 4, the regular method for shear resistance has been removed from the assembly (traditionally wood sheathing over the exterior of the building). Due to this, alternative methods for providing shear resistance must be incorporated into the design.

A common approach is to install exterior structural wood sheathing at the corners and at regular intervals as needed to provide for the lateral load resistance requirements for the location (wind and seismic). Installing the structural wood sheathing to exterior interferes with the installation of the insulating sheathing. This can create problems with drainage plane continuity and thermal bridging (due to the reduction in insulation thickness)

The recommendation is to use systems and techniques that can be installed flush with the exterior face of the wood studs. This way the insulation can be installed in a continuous uniform thickness over the entire exterior wall area. Some of the methods to achieve this are through the use of metal cross bracing or inset shear panels.

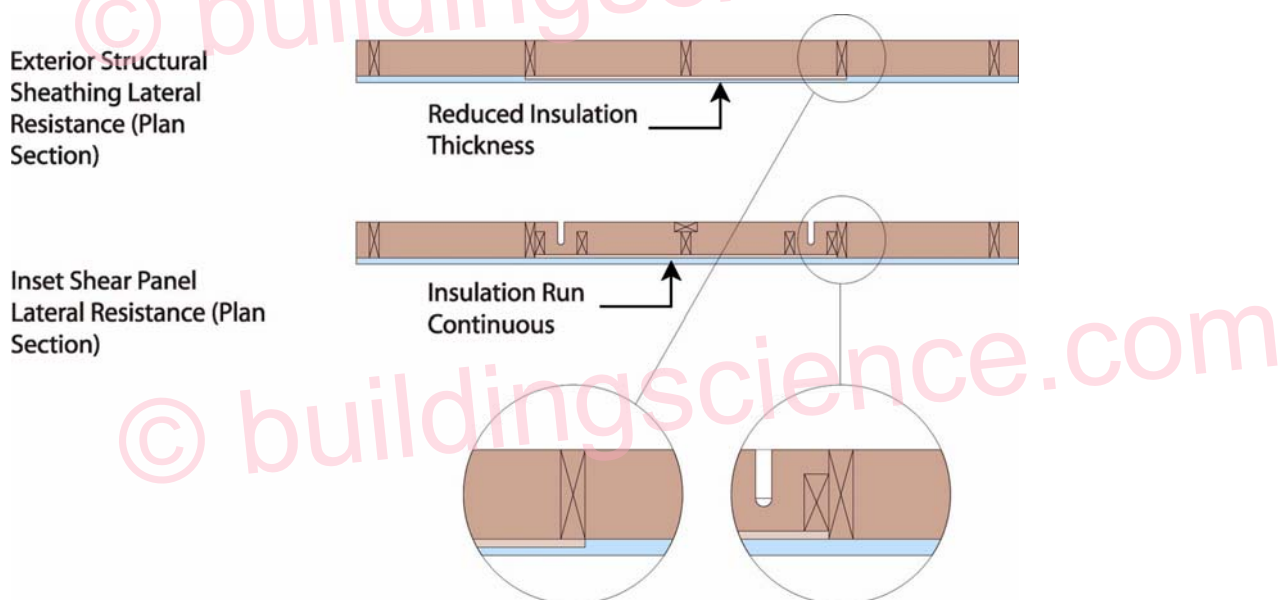

With metal cross bracing the thickness of the metal braces are insignificant and do not interfere with the installation of the insulating sheathing. The capacity of the metal cross bracing, however, may not be adequate for areas with high wind loads and/or seismic activity. In these locations, a more robust form of lateral load resistance may be needed.

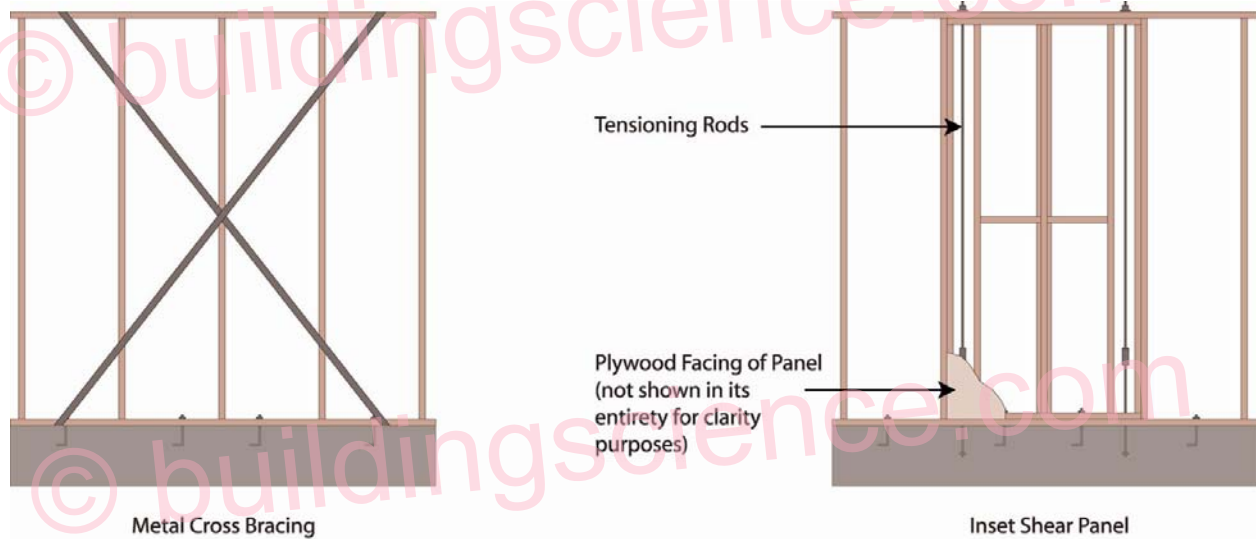

Inset shear panels can provide for high levels of lateral load resistance and can be used in all wind and seismic zones. Inset shear panels are wood framed panels that fit within the stud spacing of the wall assembly. In this way, the exterior face of the panel is flush with the exterior face of the wood studs.

Depending on the area of the country different requirements for wind and seismic resistance are required. The method chosen will depend on the individual code requirements for the area.

