

Joseph Lstiburek, Ph.D., P.Eng, ASHRAE Fellow

Building Science

Adventures In Building Science
Don't Do Stupid Things....

www.buildingscience.com

1

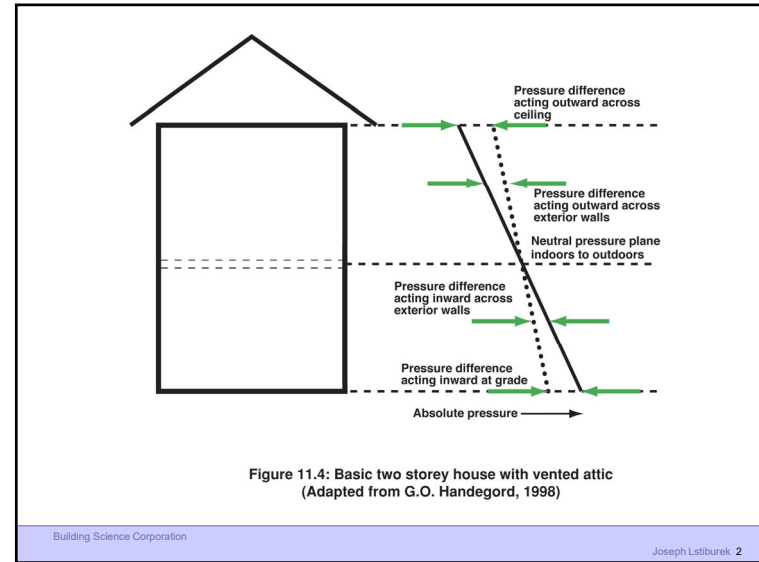

2



3

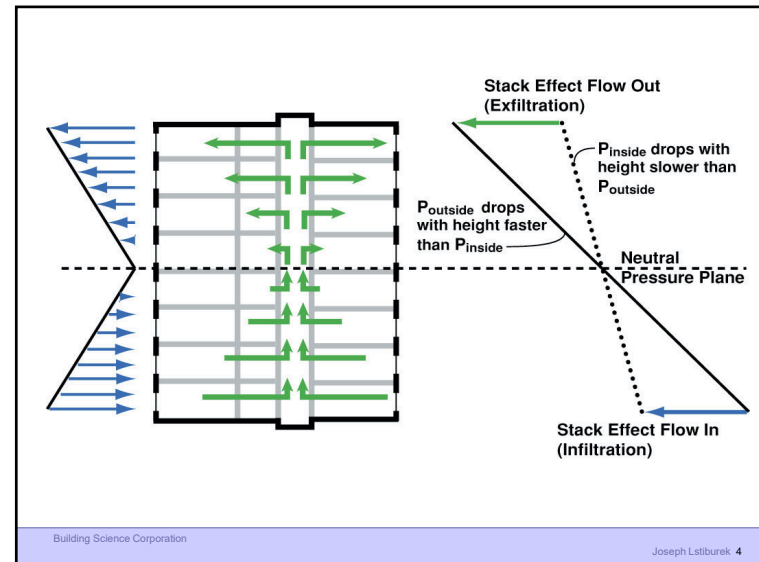

4

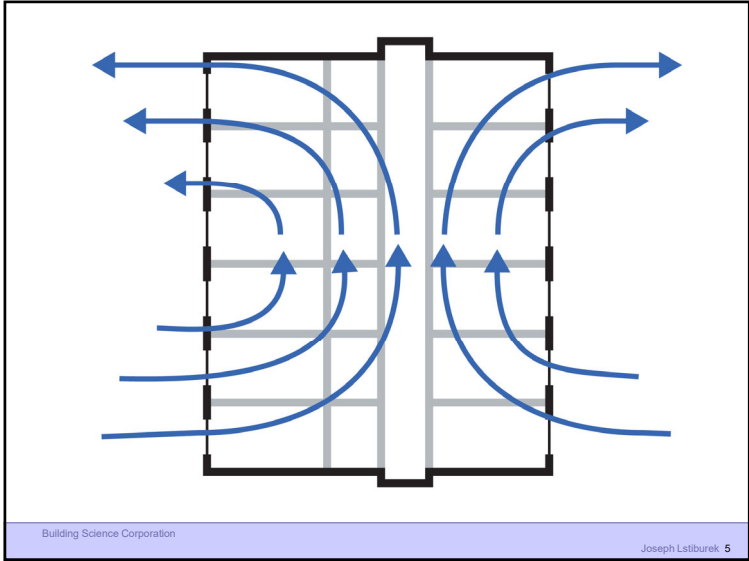

5

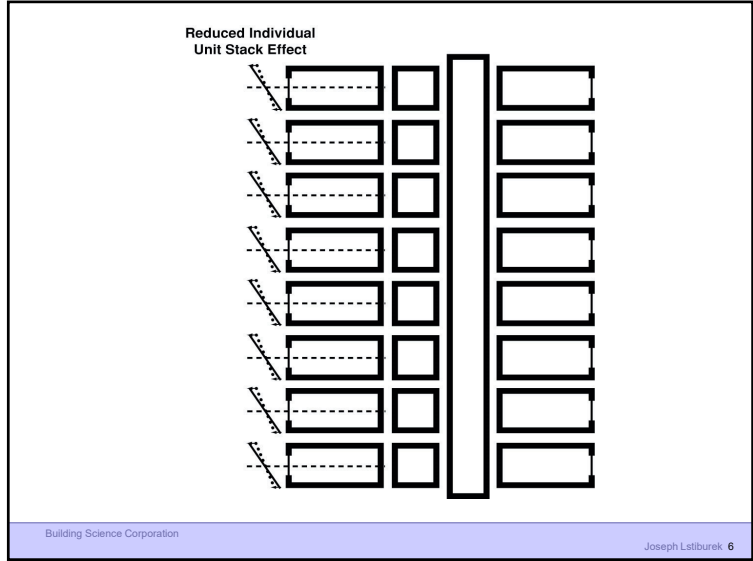

6

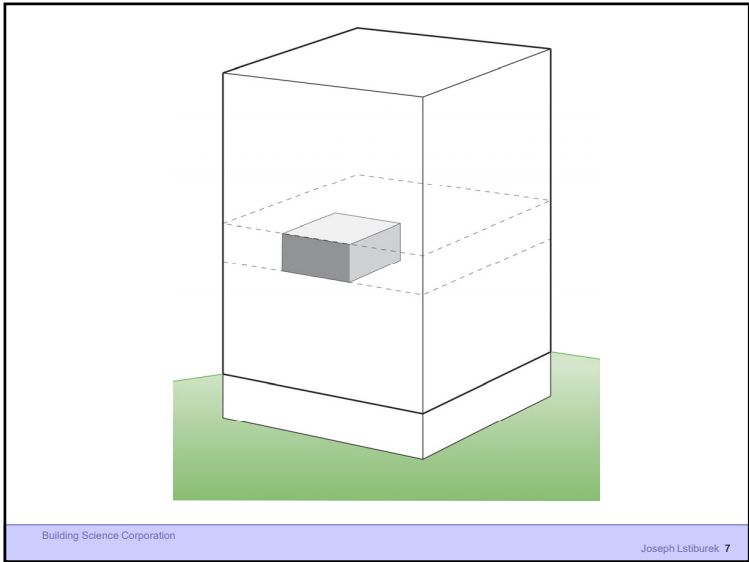

7

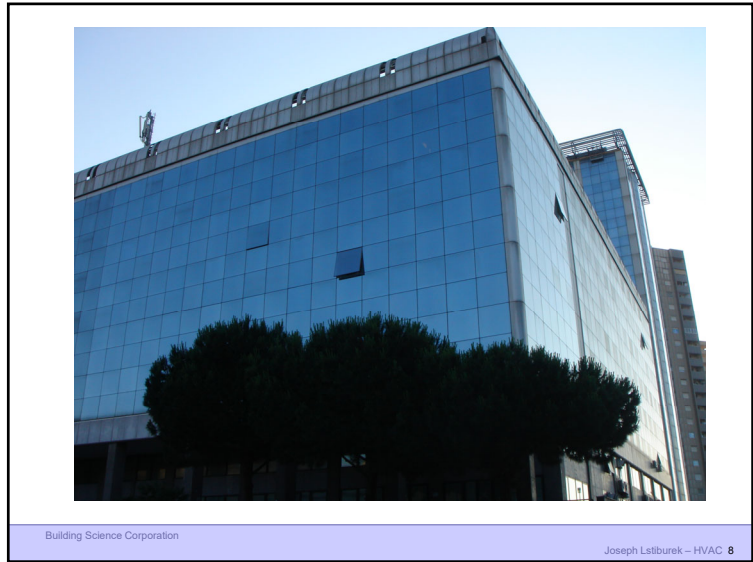

8

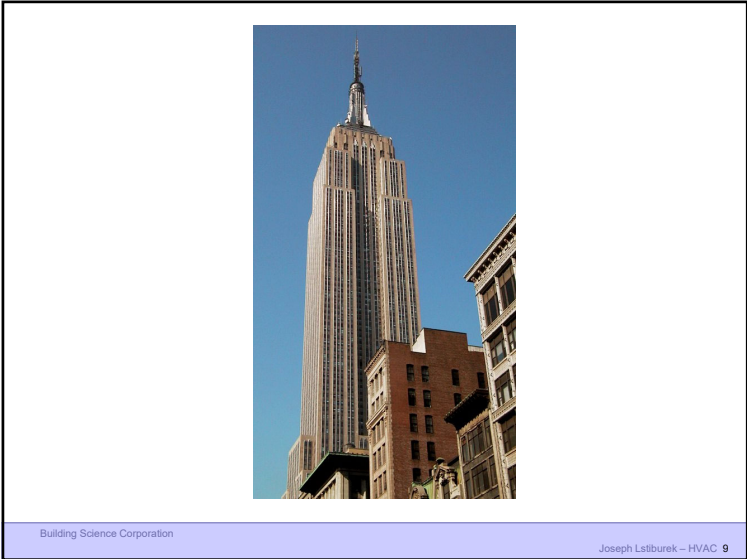

9

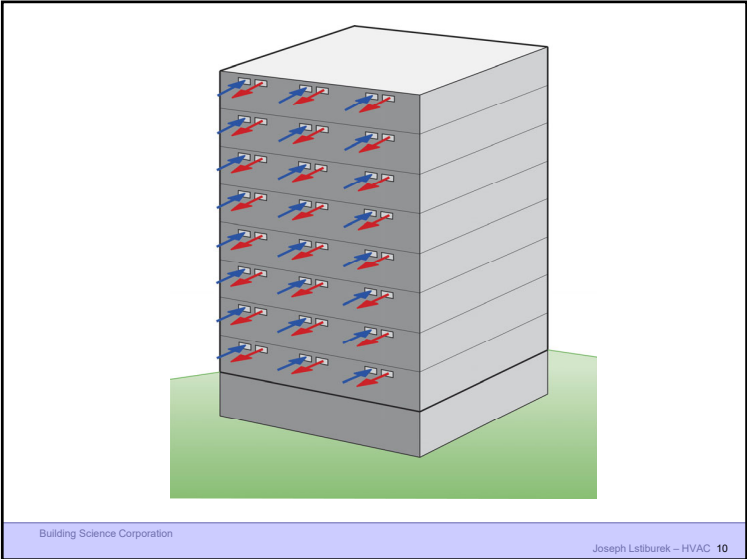

10

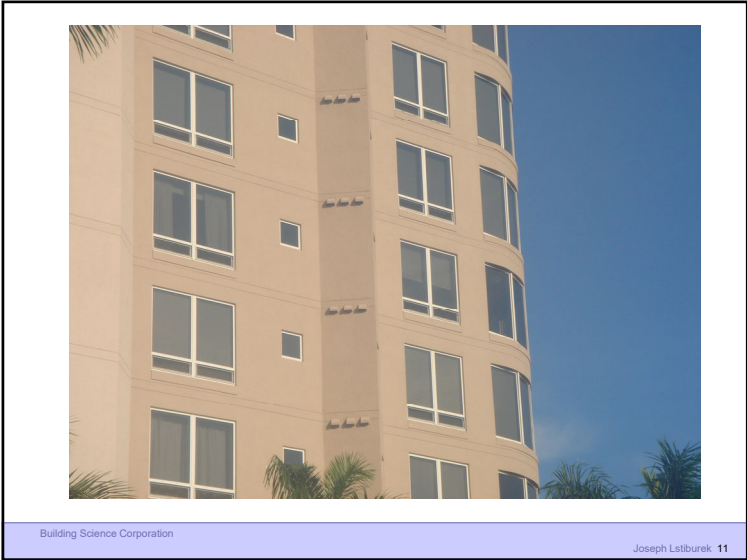

11

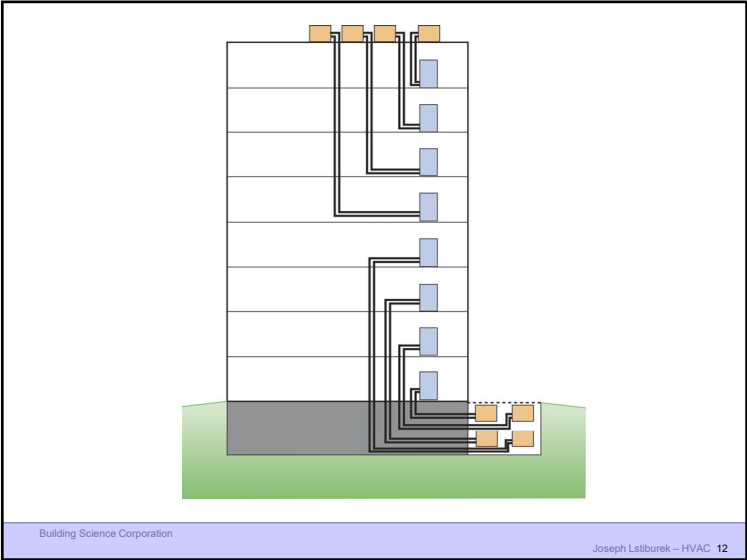

12



13



14

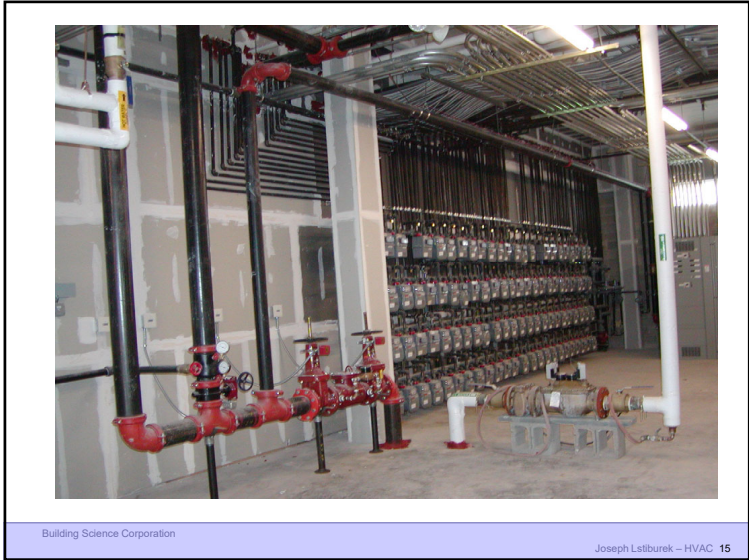

15

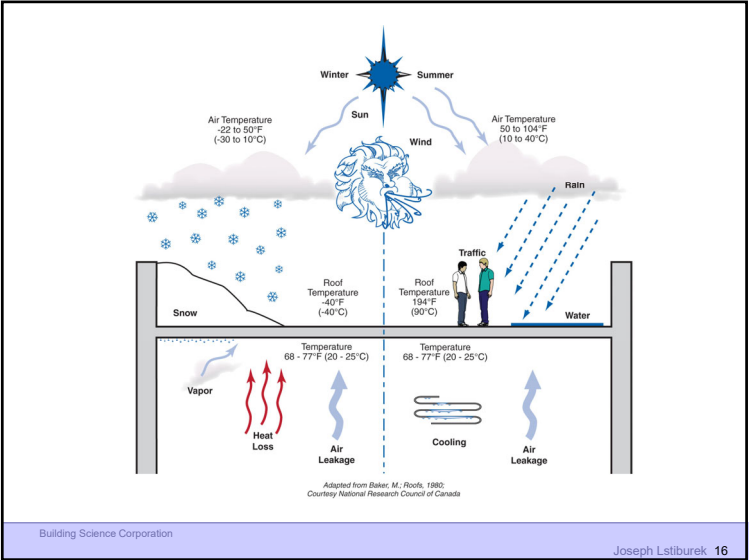

16

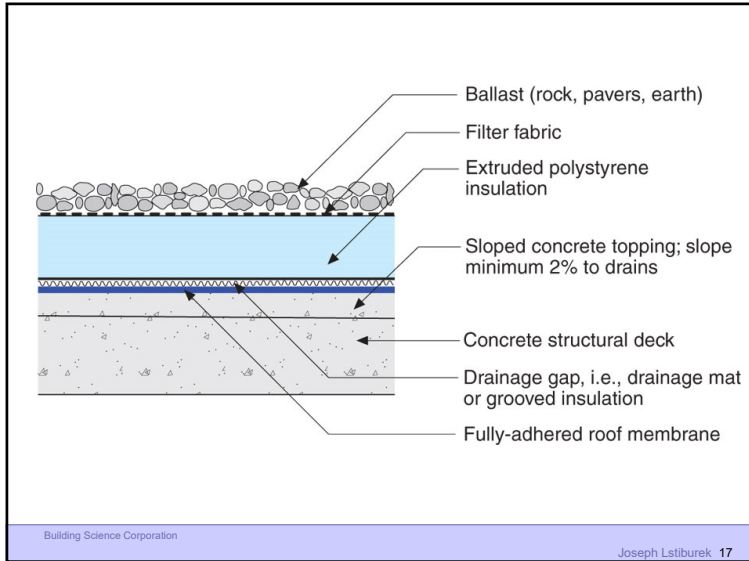

17



18

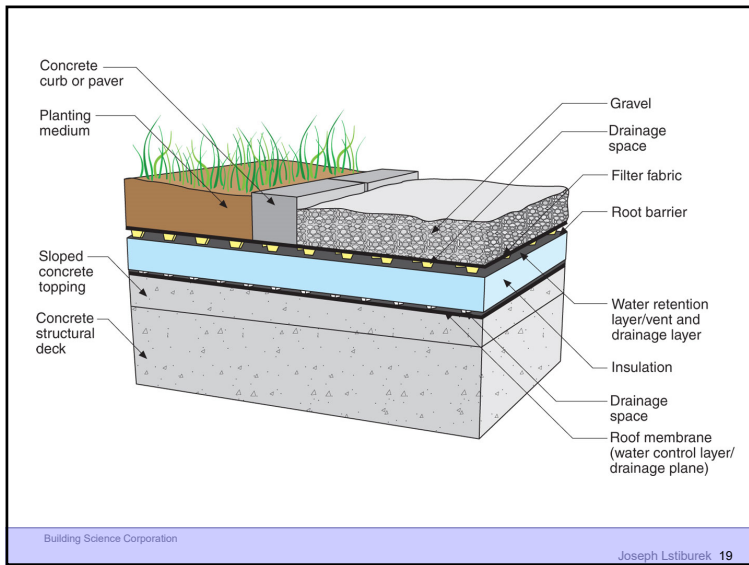

19

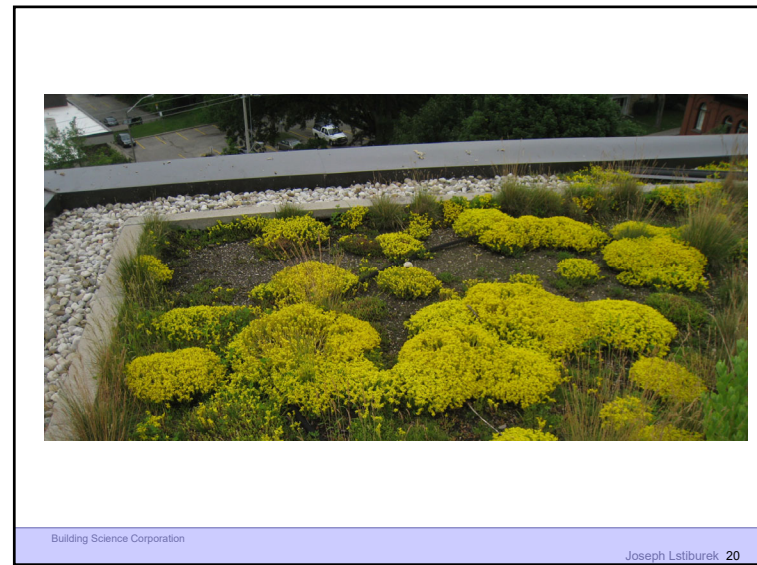

20

Stucco Evolved As A Barrier System

Building Science Corporation Joseph Lstiburek 21

21

Mass Wall Evolution

Building Science Corporation Joseph Lstiburek 22

22

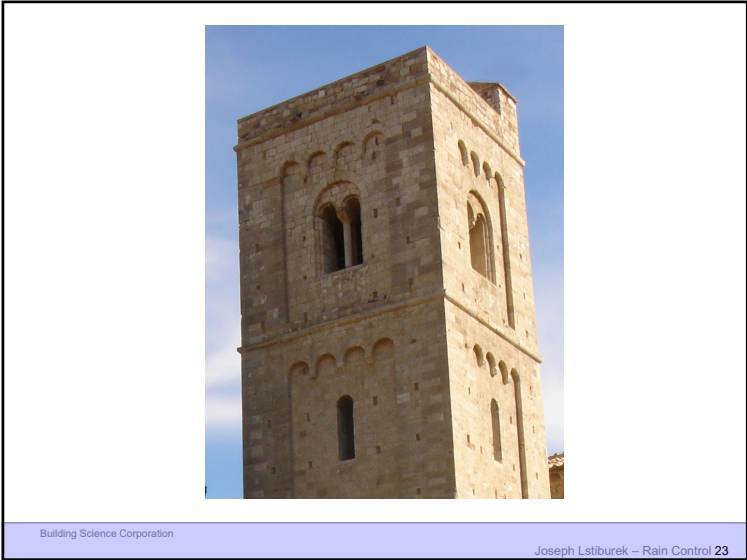

23

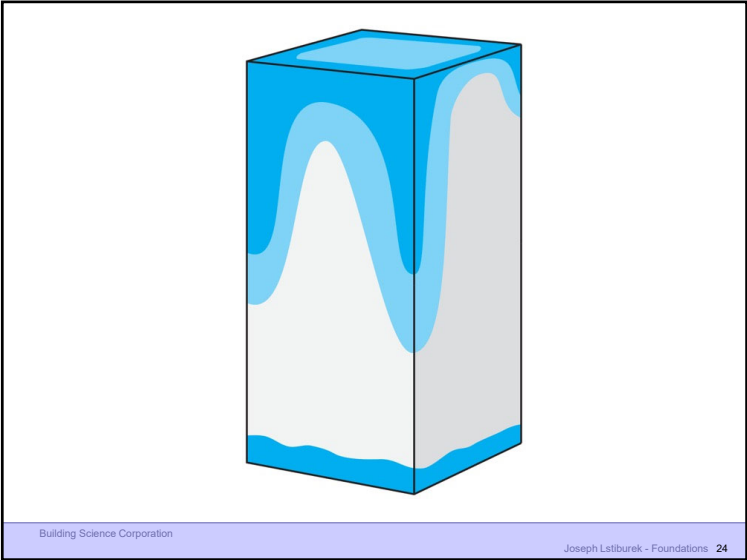

24

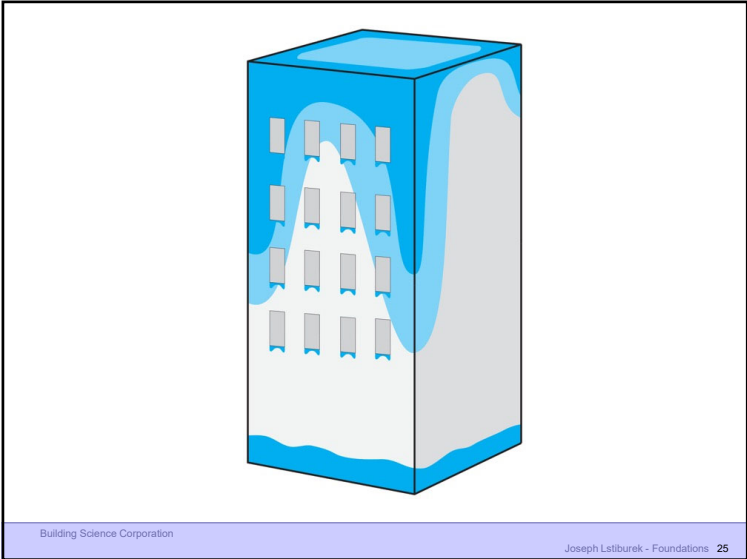

Building Science Corporation

Joseph Lstiburek - Foundations 25

25

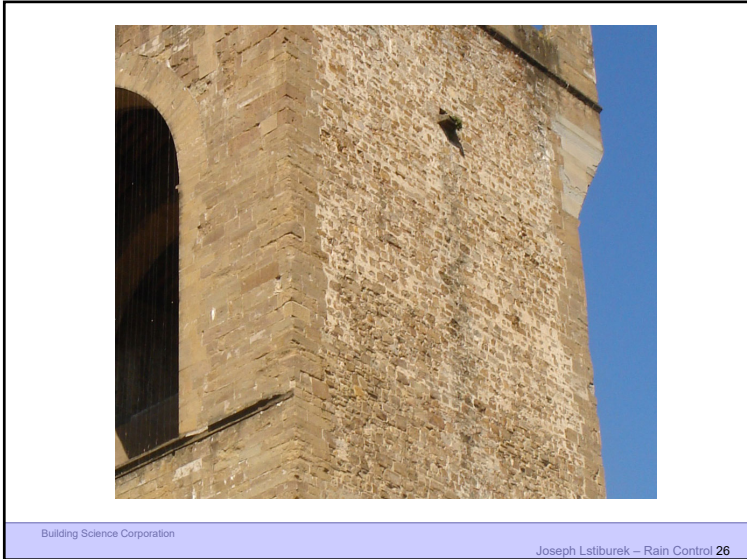

Building Science Corporation

Joseph Lstiburek - Rain Control 26

26

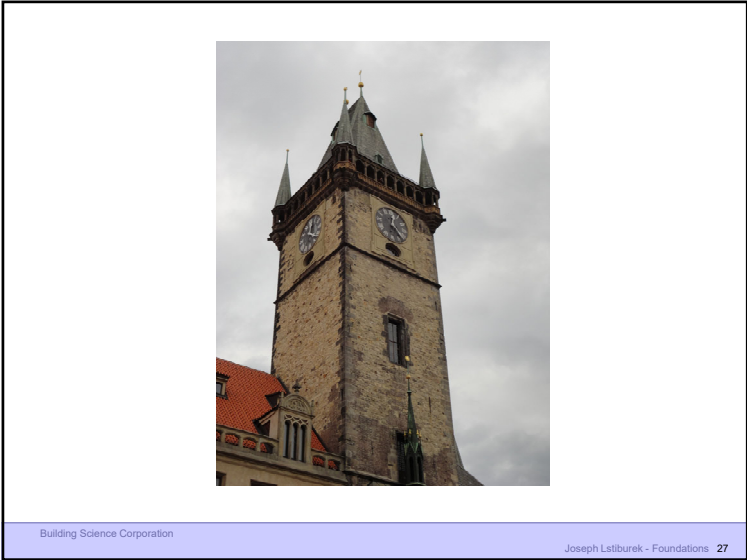

Building Science Corporation

Joseph Lstiburek - Foundations 27

27



Building Science Corporation

Joseph Lstiburek - Rain Control 28

28

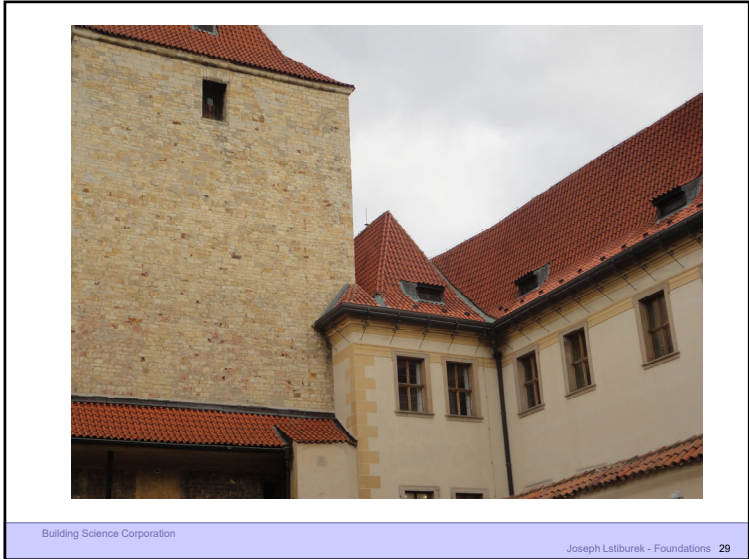

29

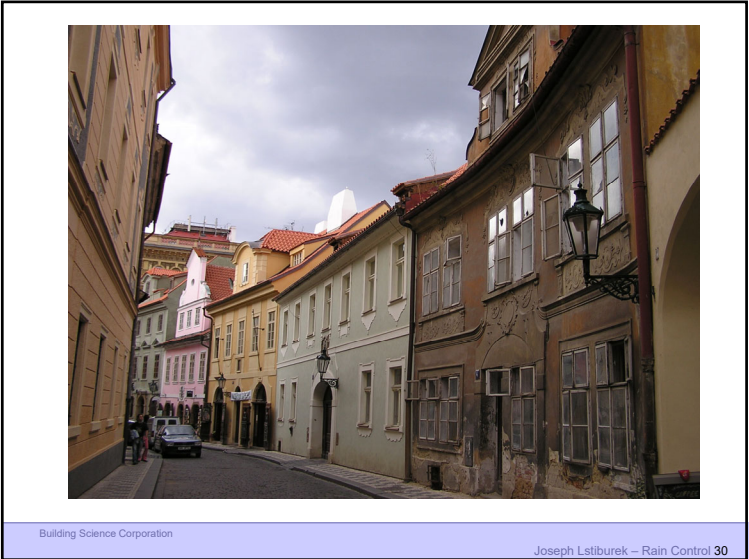

30

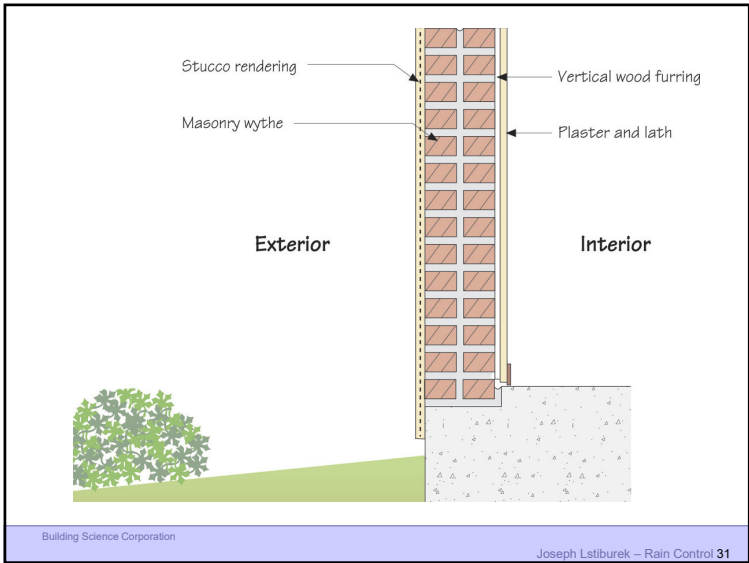

31

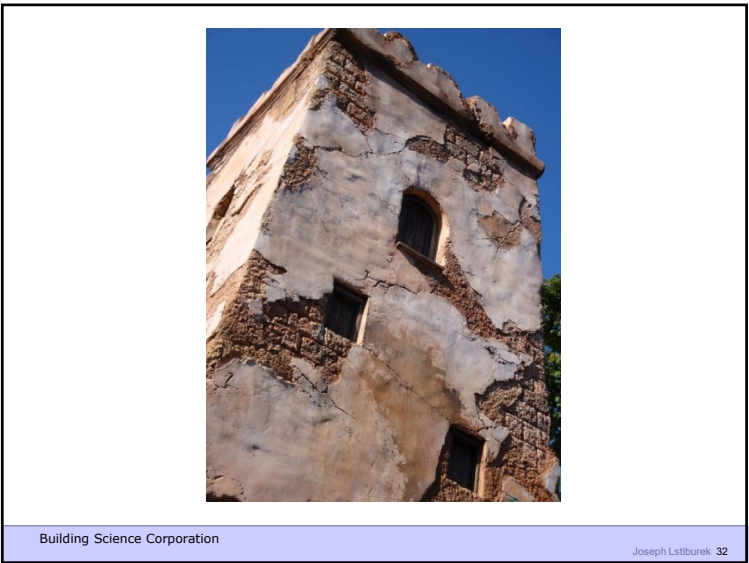

32



33



34



35

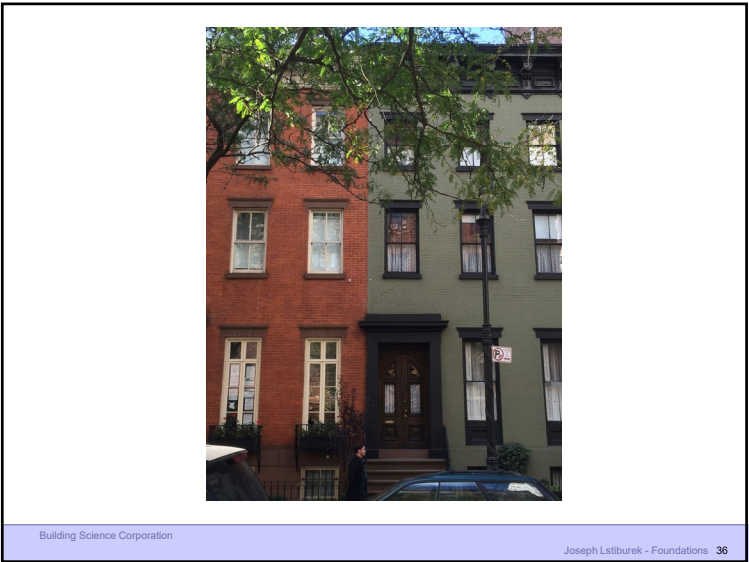

36

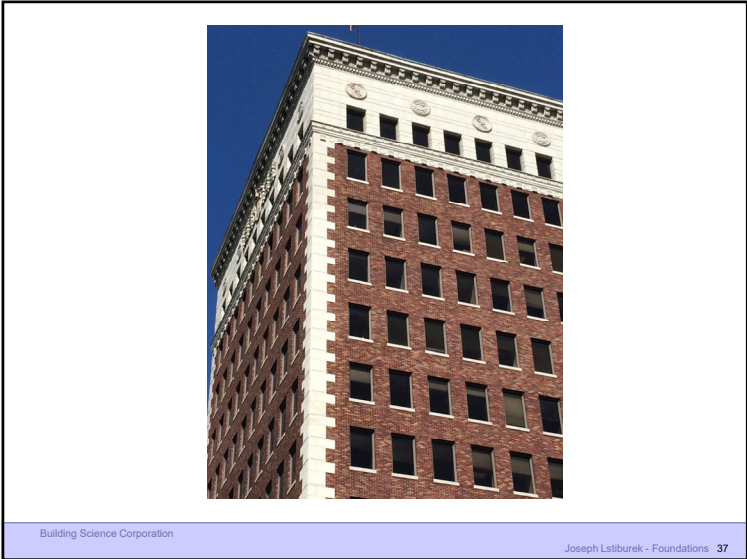

37



38

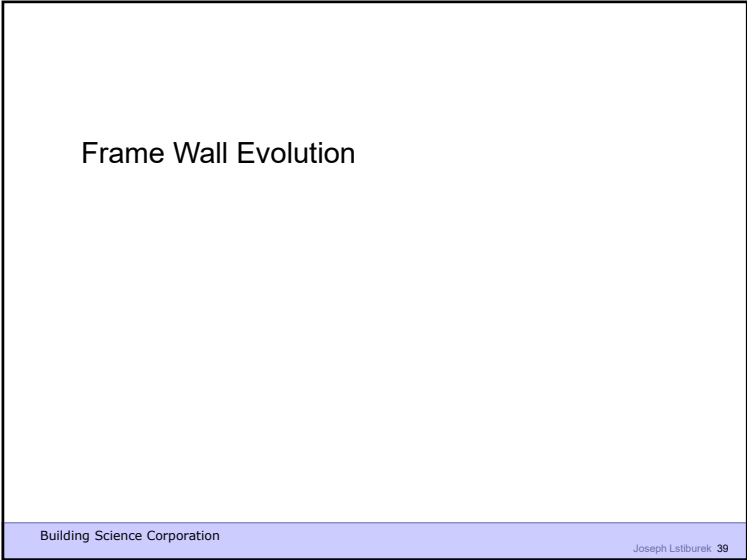

39

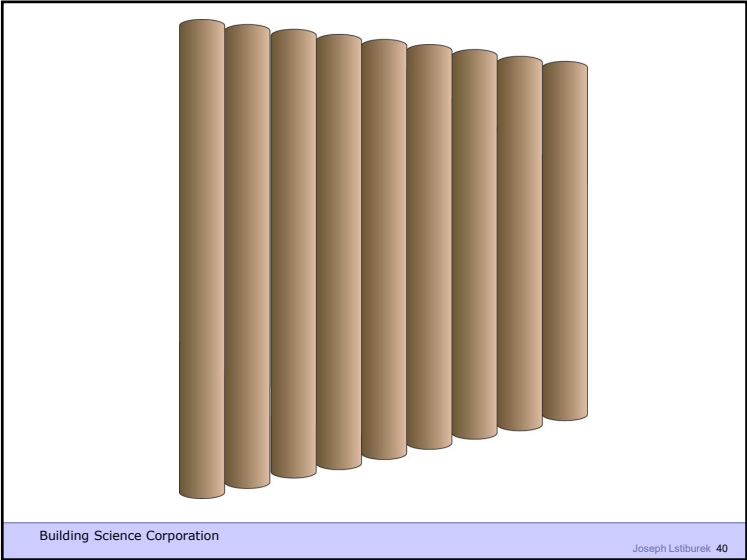

40

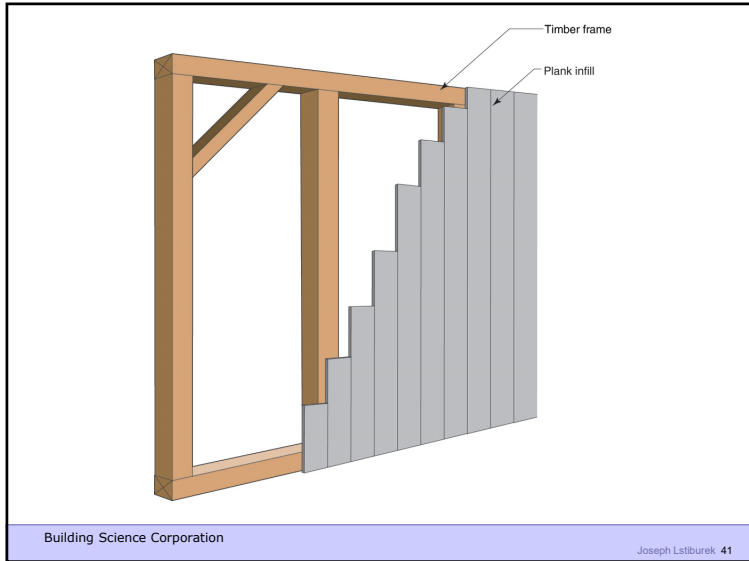

41

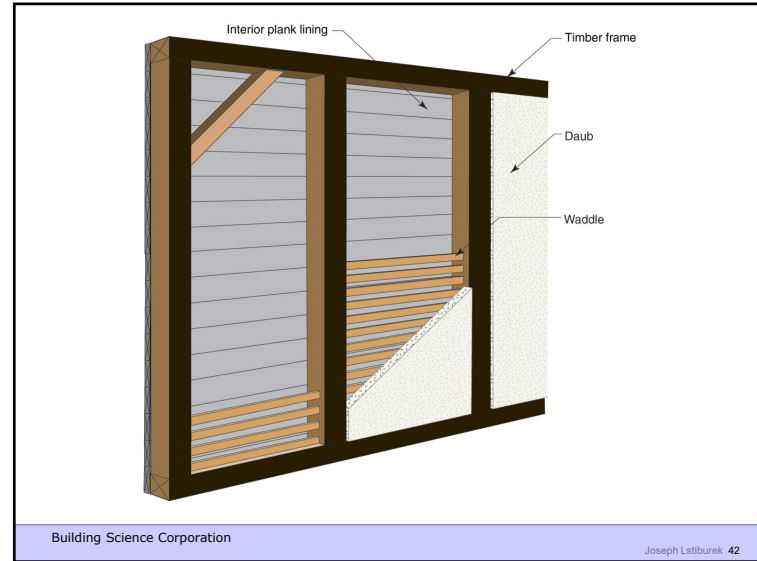

42

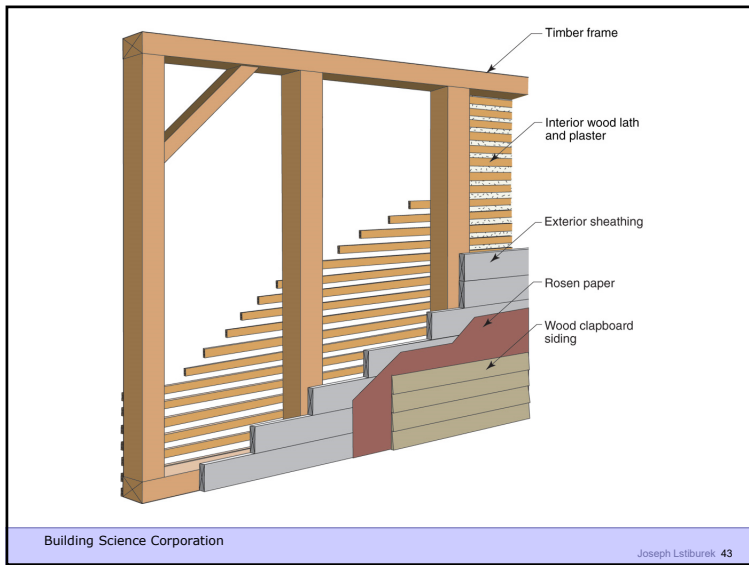

43

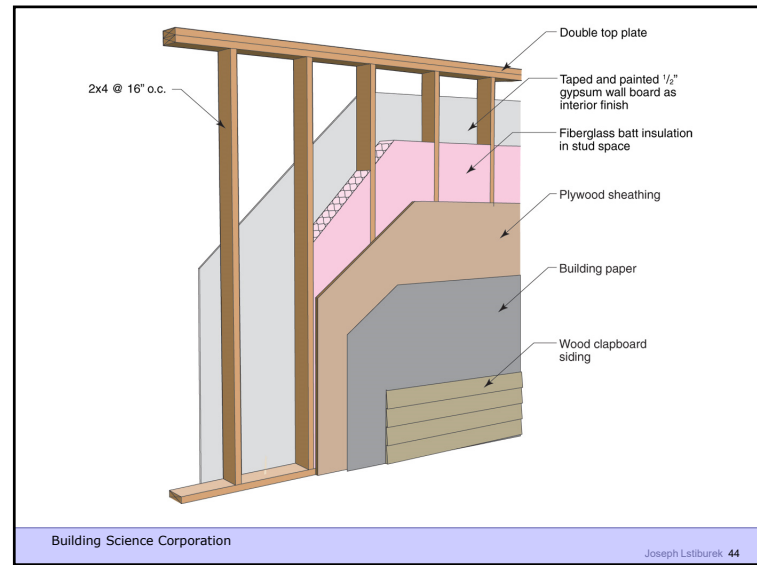

44

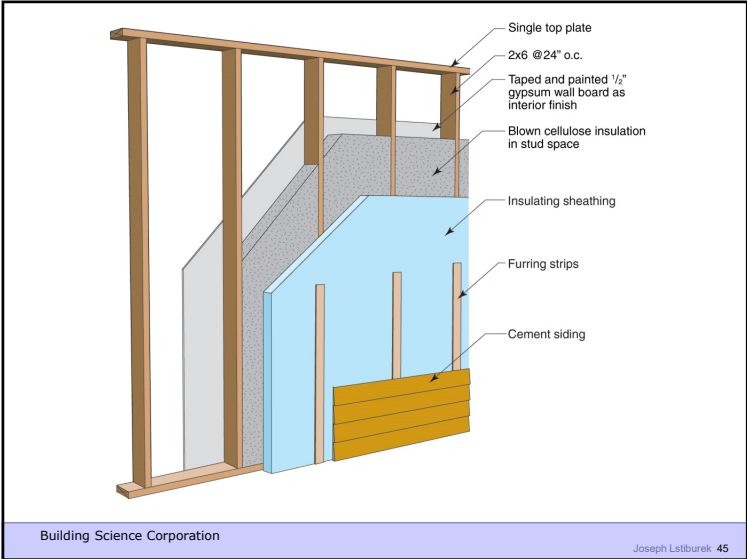

45

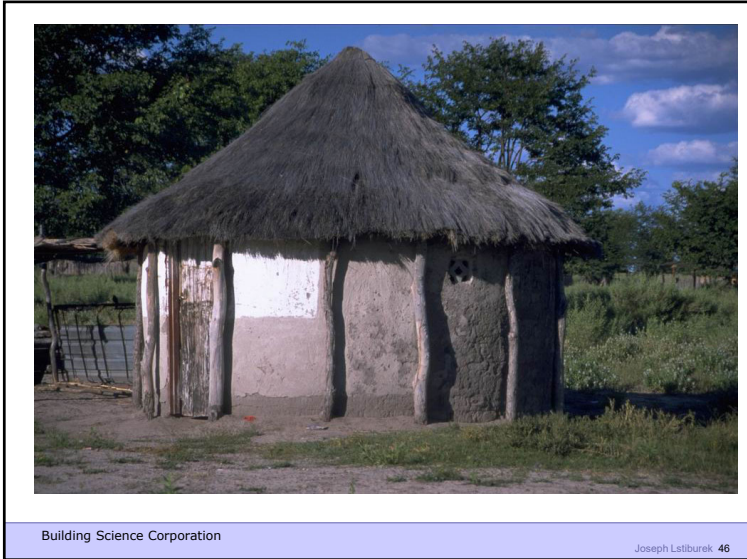

46

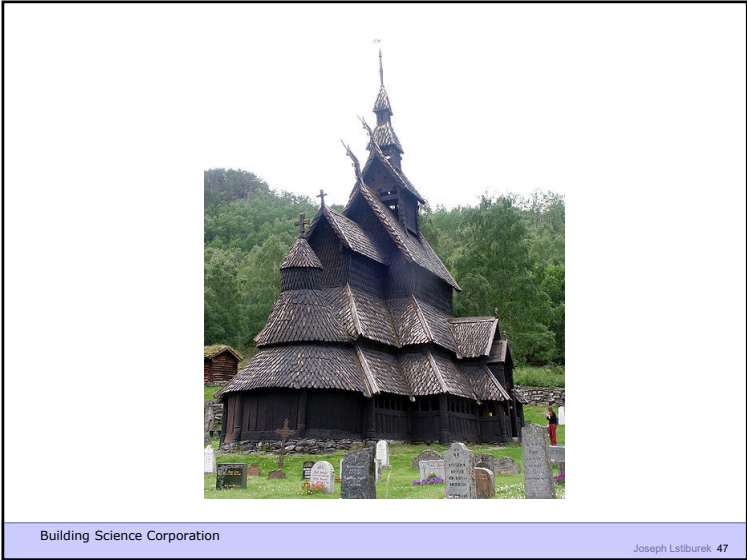

47

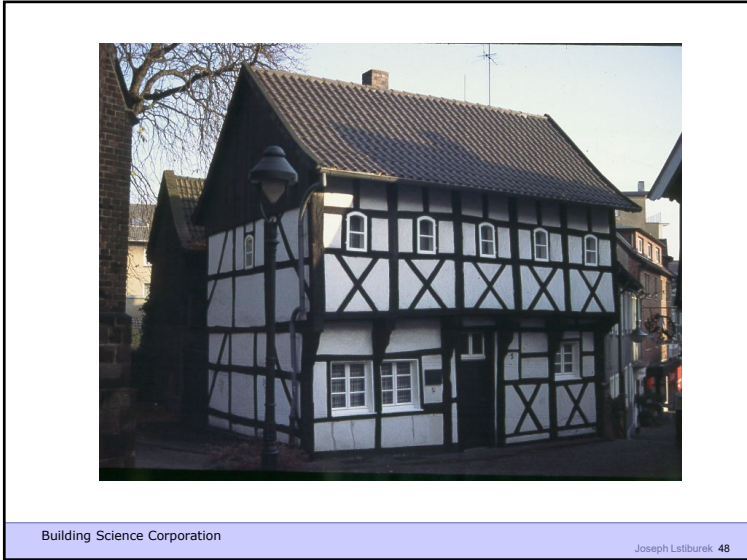

48

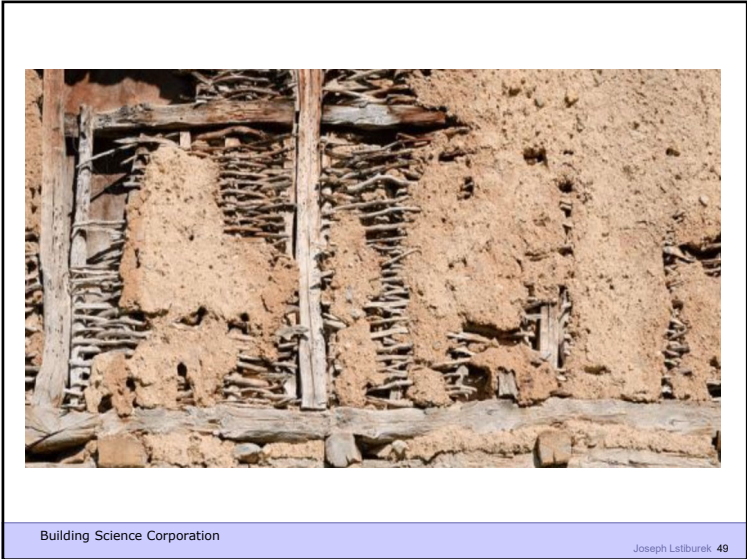

Building Science Corporation

Joseph Lstiburek 49

49



Building Science Corporation

Joseph Lstiburek 50

50



Building Science Corporation

Joseph Lstiburek 51

51

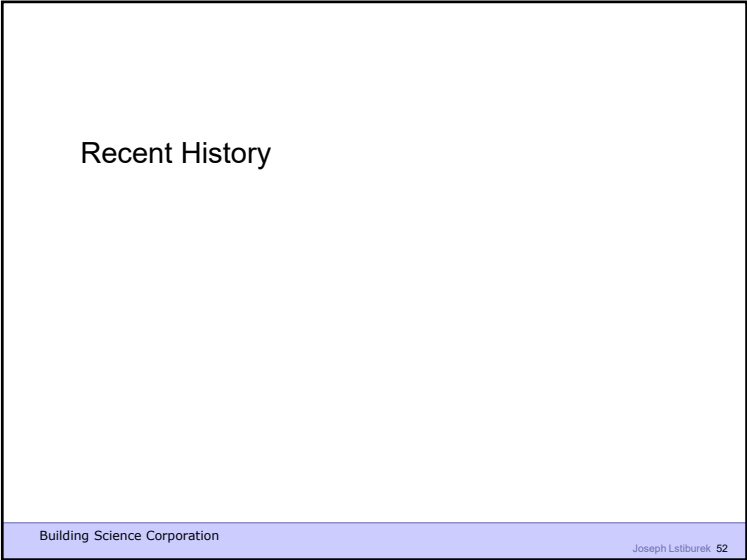

Building Science Corporation

Joseph Lstiburek 52

52

Exterior Insulation Finish Systems
EIFS

Building Science Corporation Joseph Lstiburek 53

53



Building Science 2007 Joseph Lstiburek – Rain Control 54

54

Exterior Insulation Finish Systems
EIFS
Barrier System
Face-Sealed Not Water Managed

Building Science Corporation Joseph Lstiburek 55

55



Building Science 2007 Joseph Lstiburek – Rain Control 56

56



57



58



59

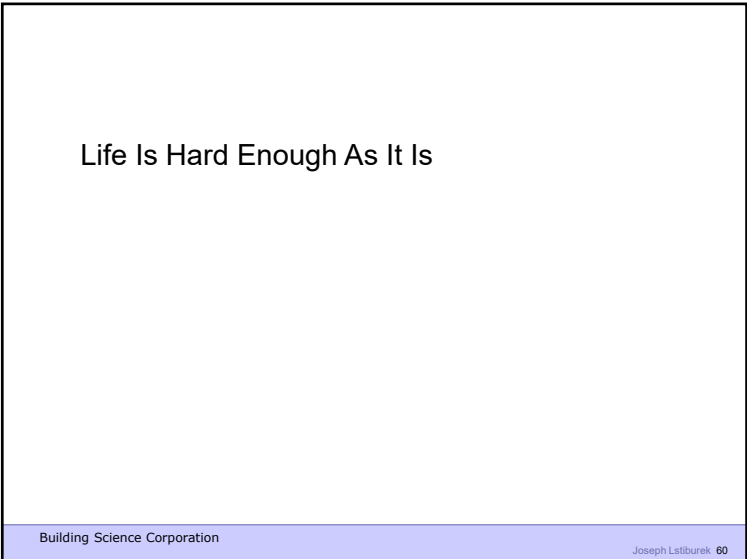

60

It's Harder When You Are Stupid

Building Science Corporation

Joseph Lstiburek 61

61

Don't Do Stupid Things

Building Science Corporation

Joseph Lstiburek 62

62



Building Science Corporation

Joseph Lstiburek 63

63



Building Science Corporation

Joseph Lstiburek 64

64



65

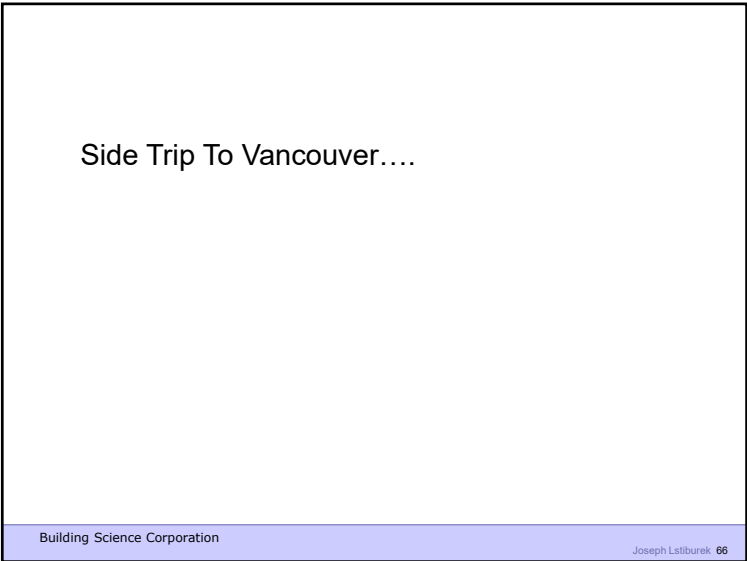

66

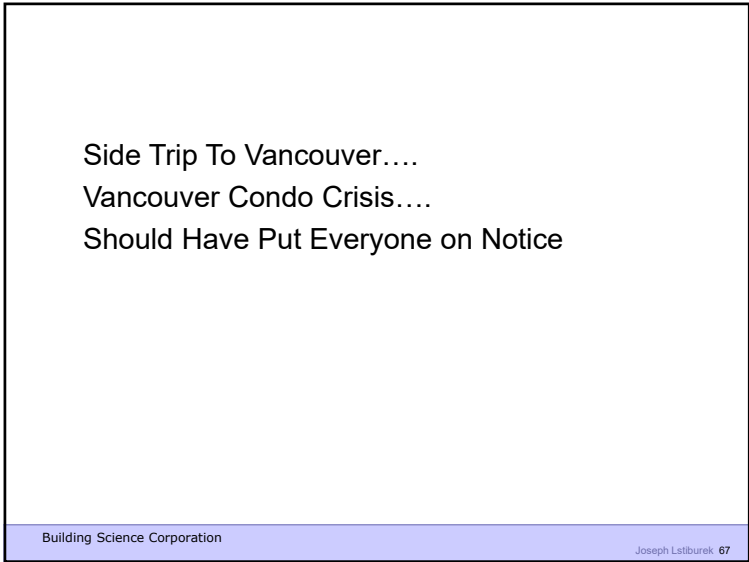

67



68

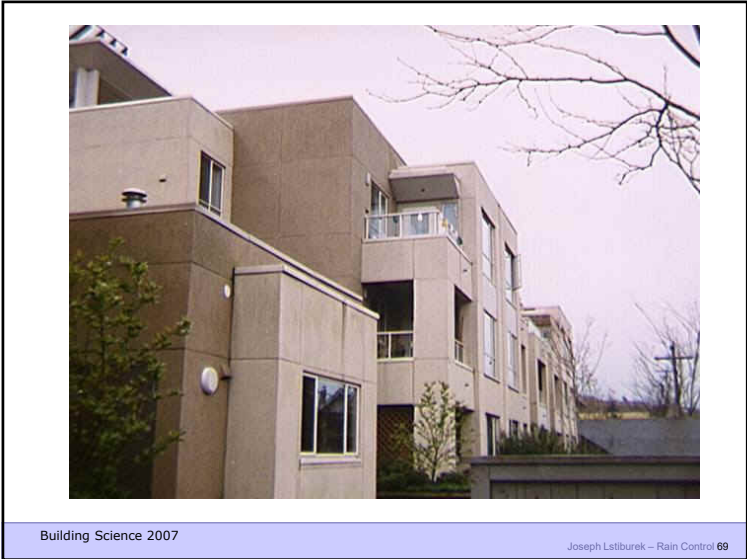

69



70



71



72



73



74

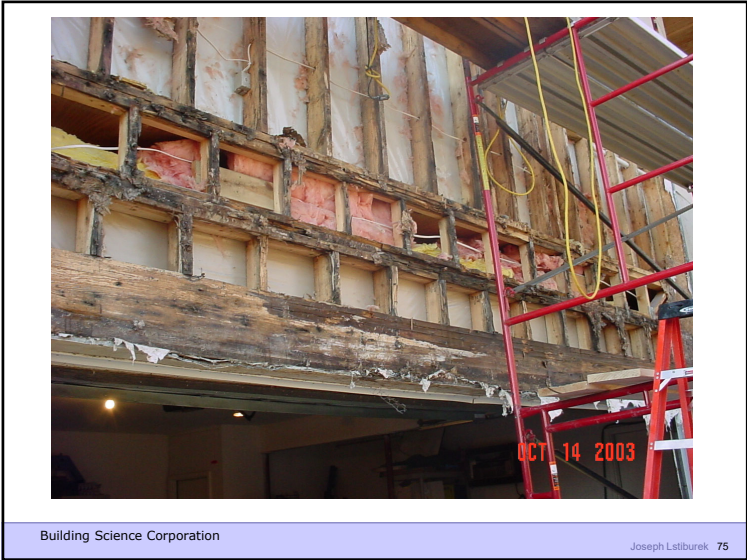

75



76

What Happened In Vancouver?
 OSB Instead of Plywood
 Non Traditional Building Wraps
 Interior Vapor Barriers
 Increased Thermal Resistance
 Portland Cement Instead of Lime

Building Science Corporation Joseph Lstiburek 77

77

Materials
 Inward Drive
 Energy

Building Science Corporation Joseph Lstiburek 78

78

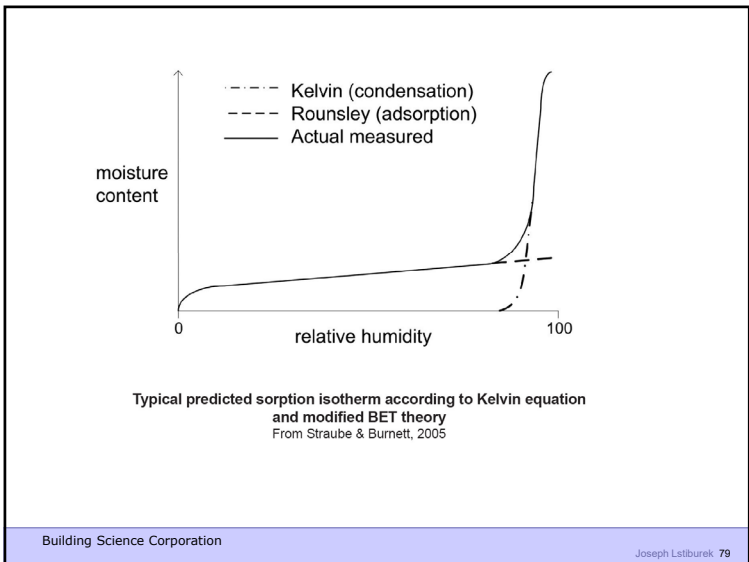

79

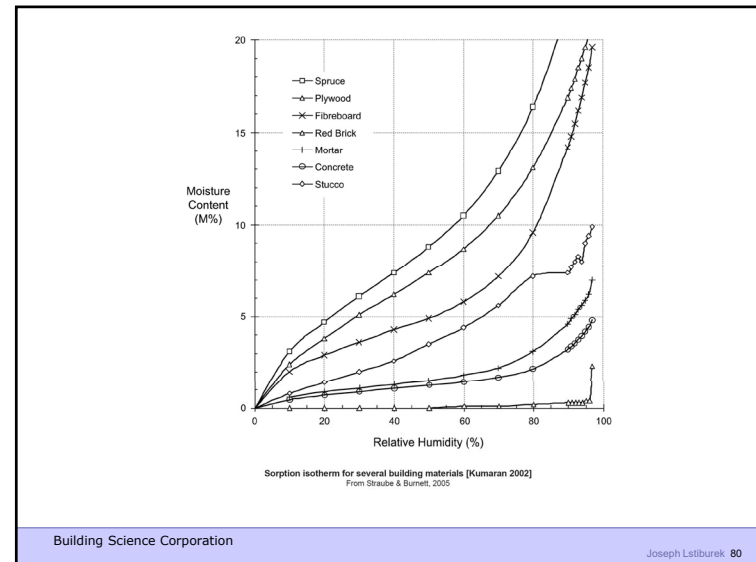

80

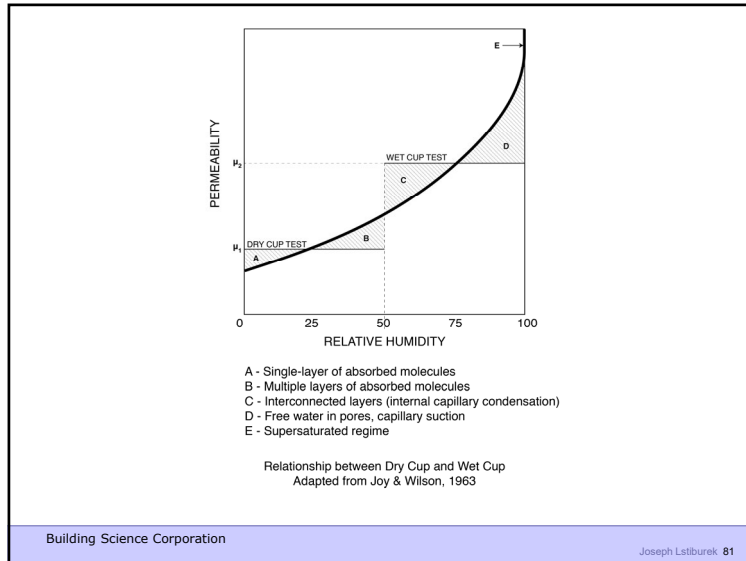

81



82

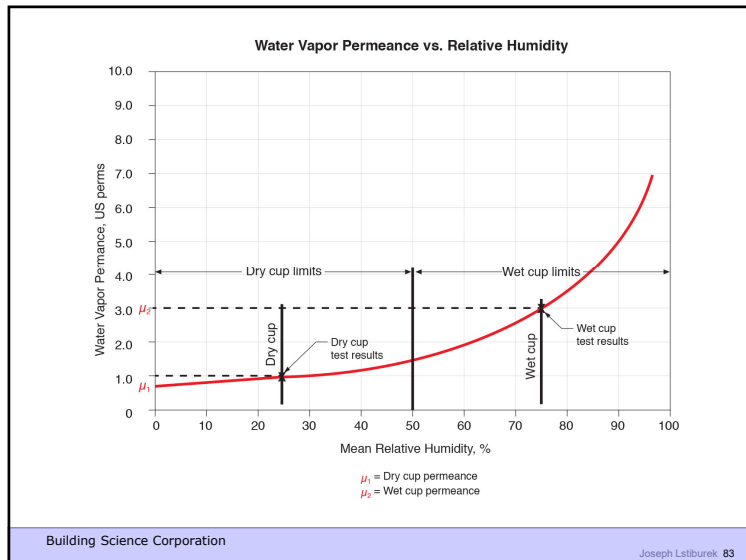

83

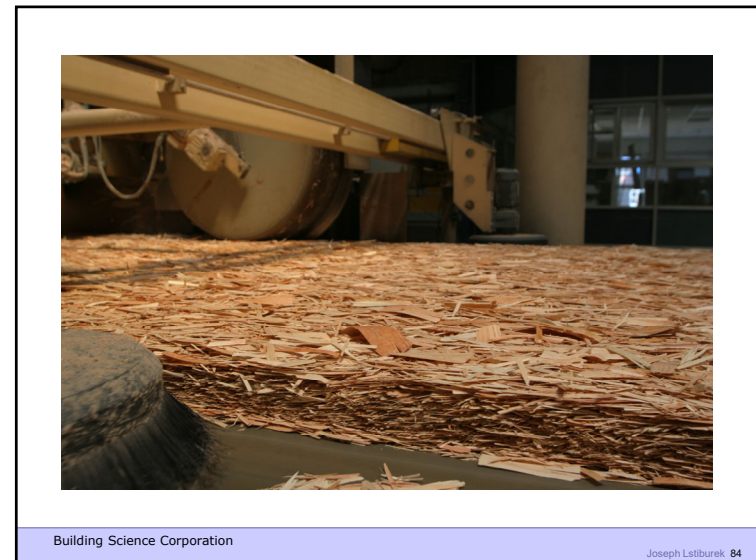

84

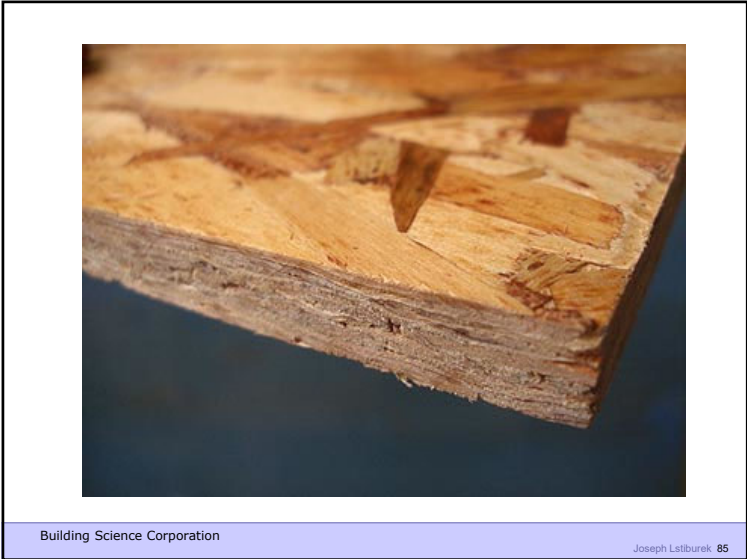

85

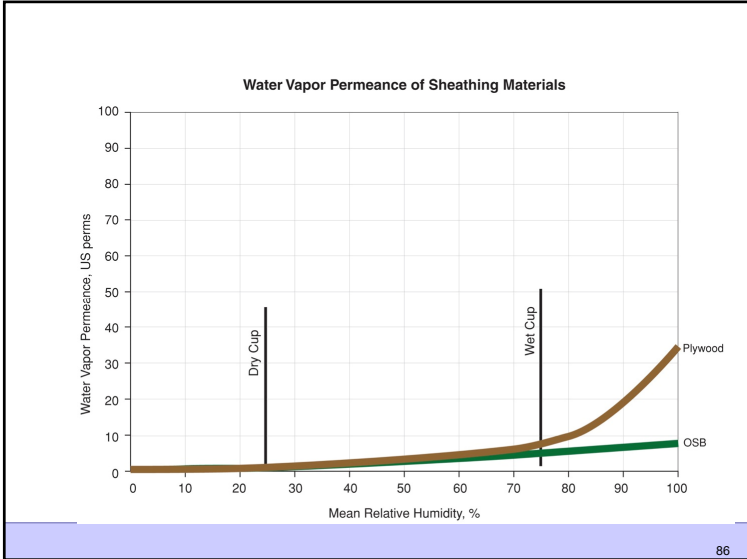

86

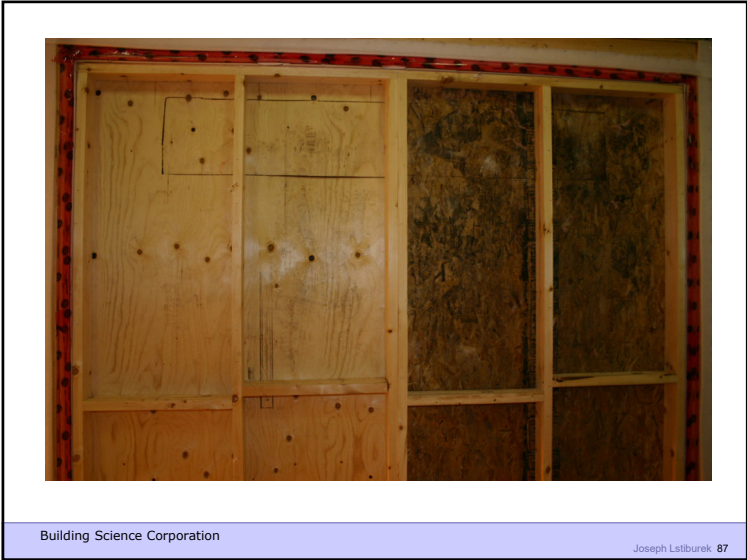

87

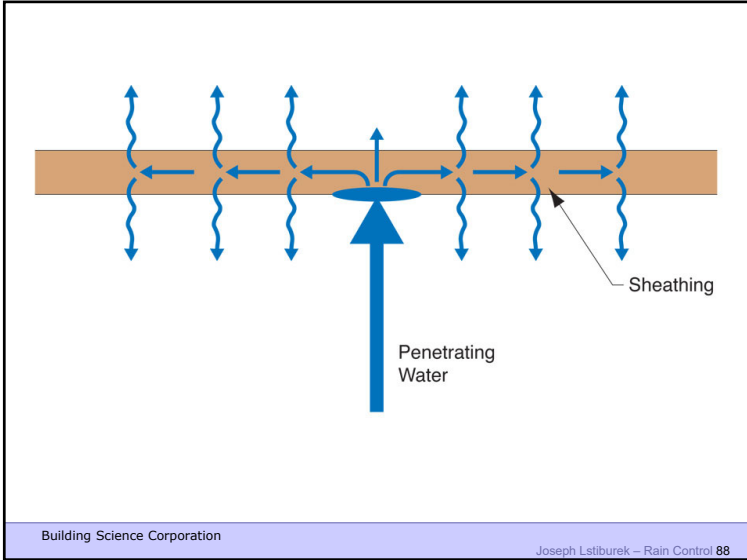

88

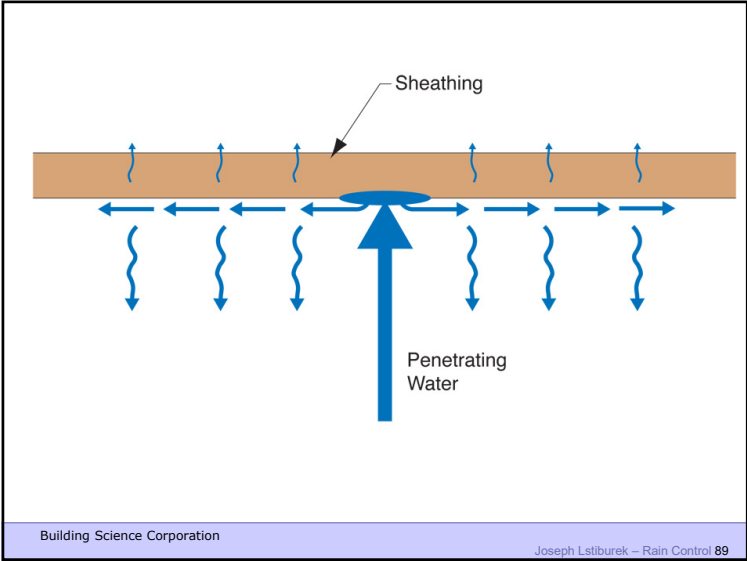

89

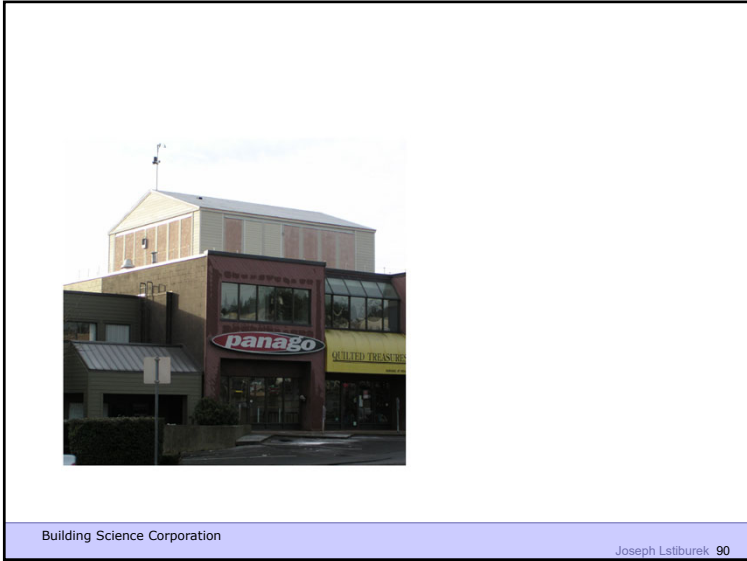

90

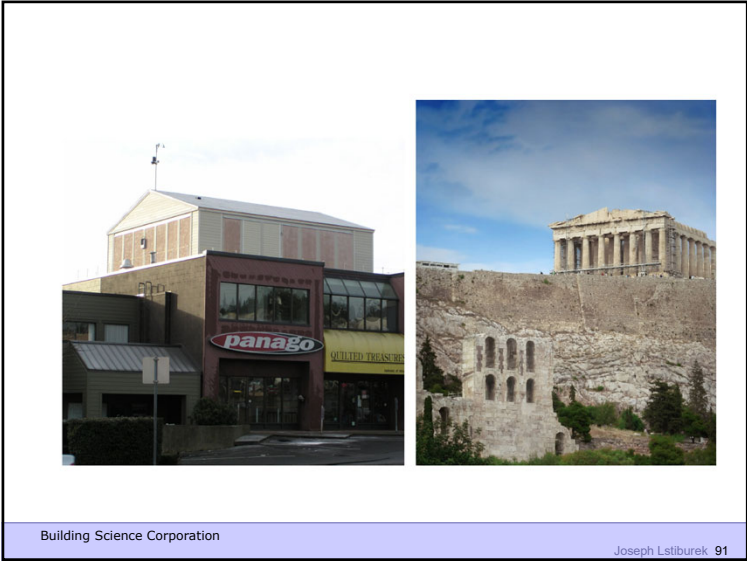

91



92

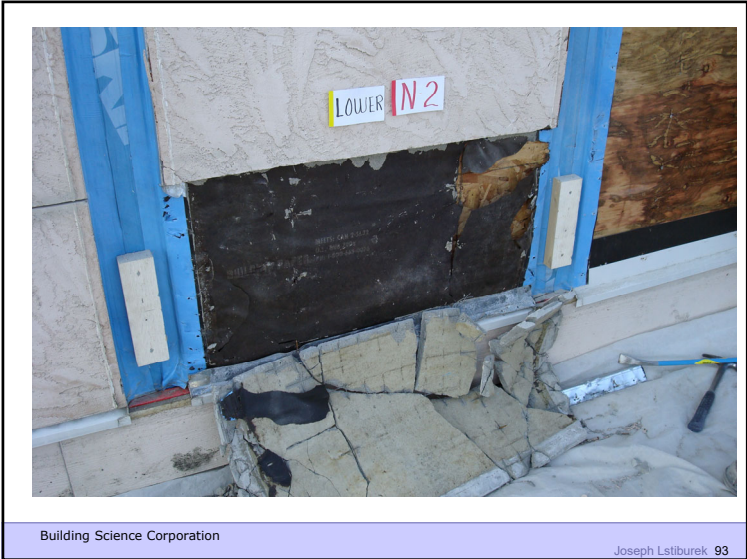

Building Science Corporation

Joseph Lstiburek 93

93



Building Science Corporation

Joseph Lstiburek 94

94



Building Science Corporation

Joseph Lstiburek - Rain Control 95

95

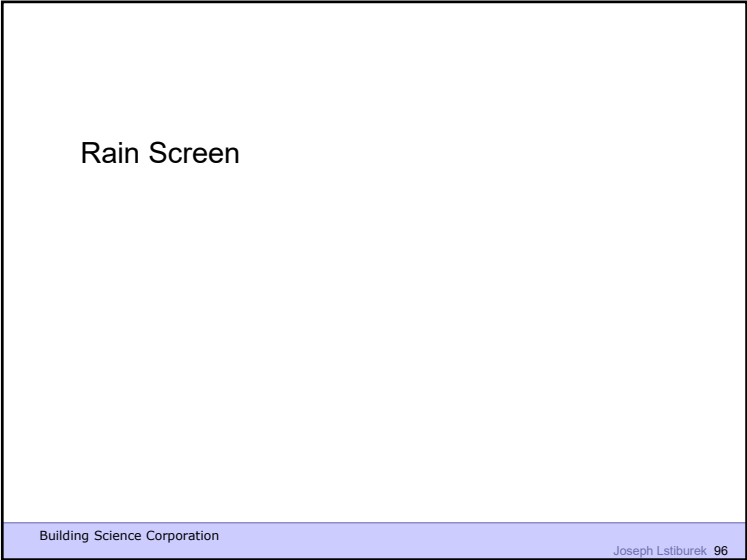

Building Science Corporation

Joseph Lstiburek 96

96

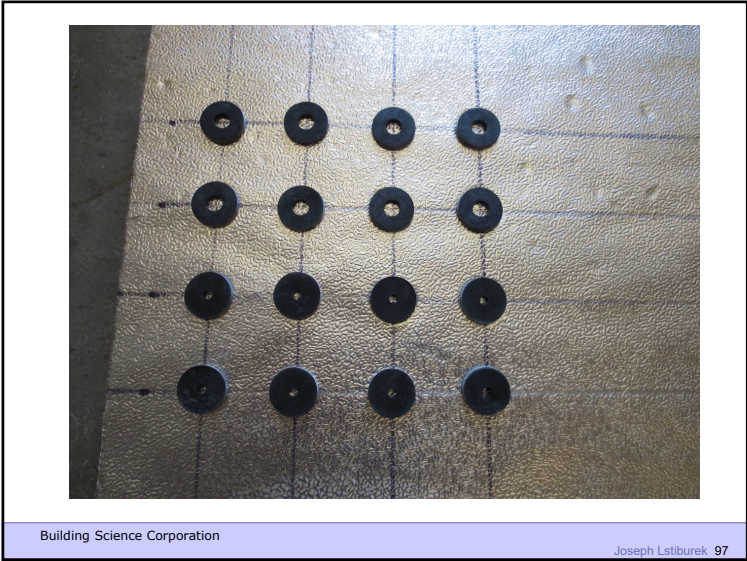

97

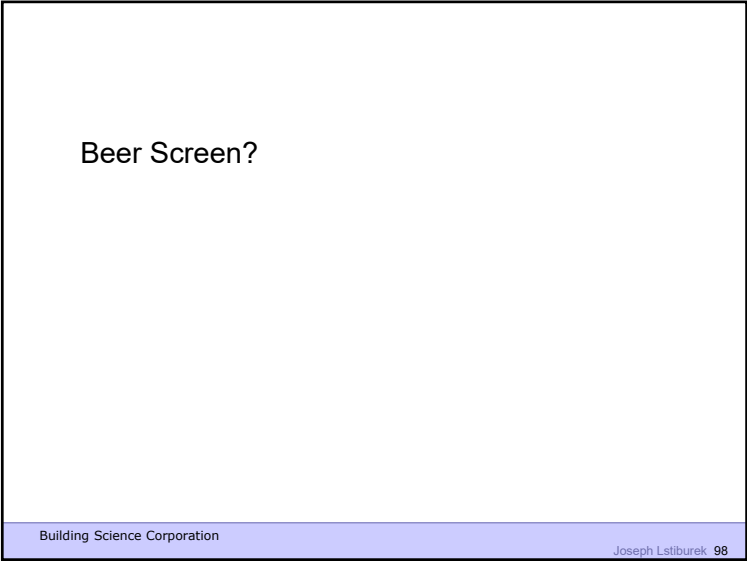

98

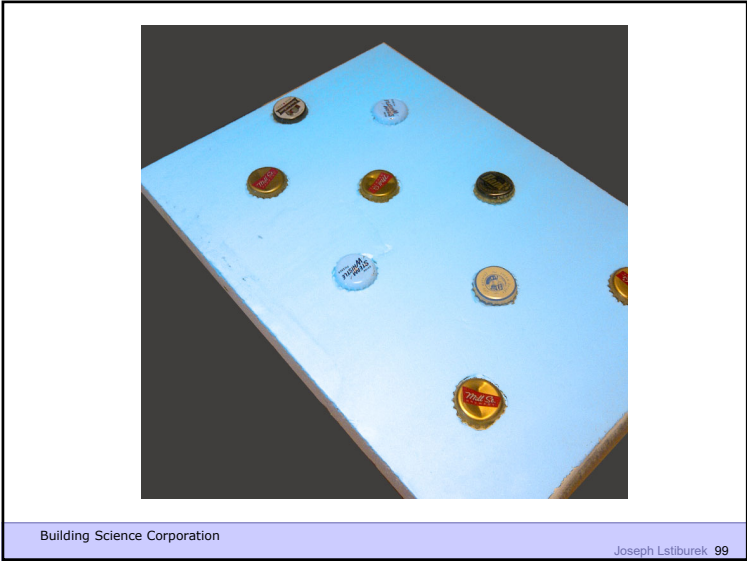

99

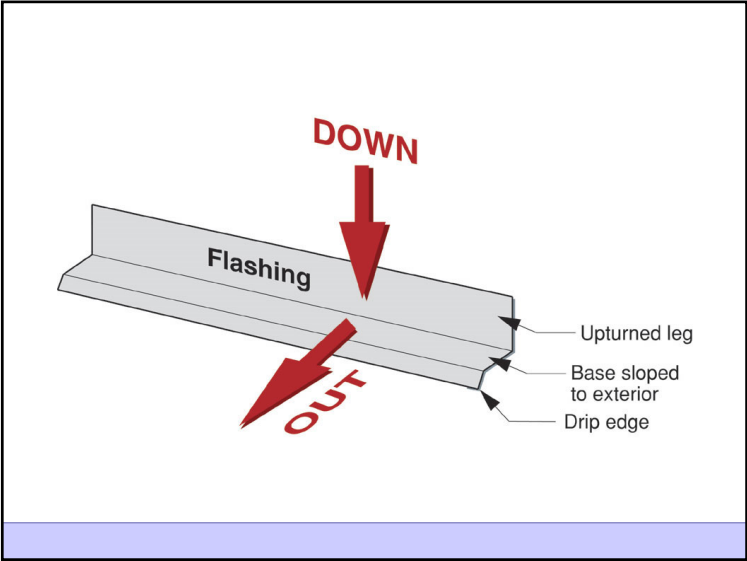

100

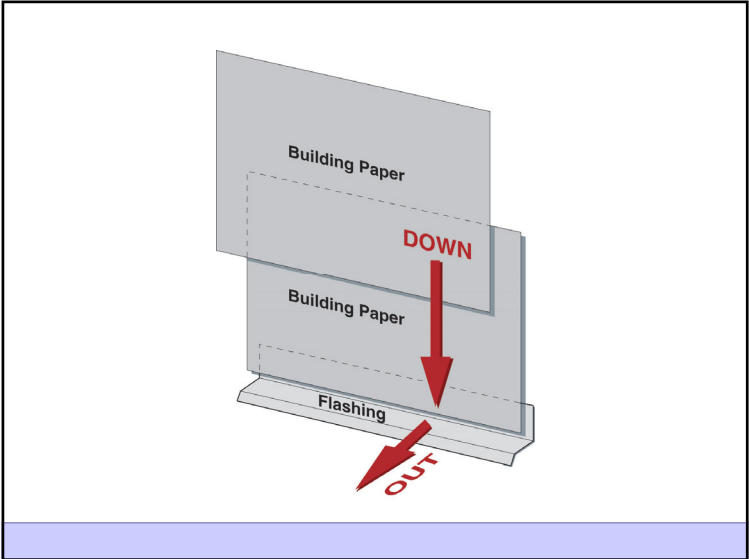

101

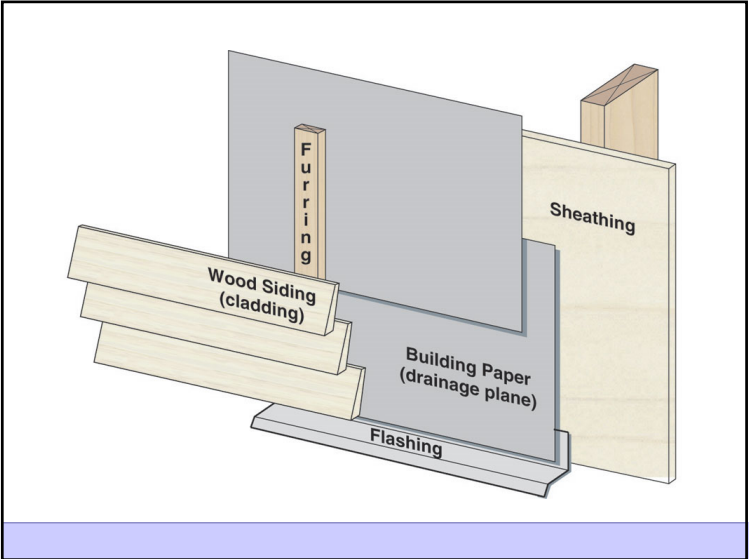

102

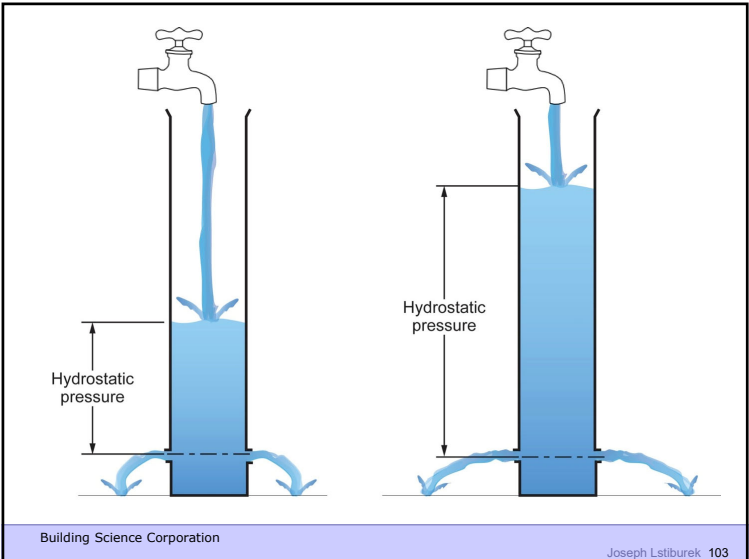

103

Building Science Corporation

Joseph Lstiburek 103

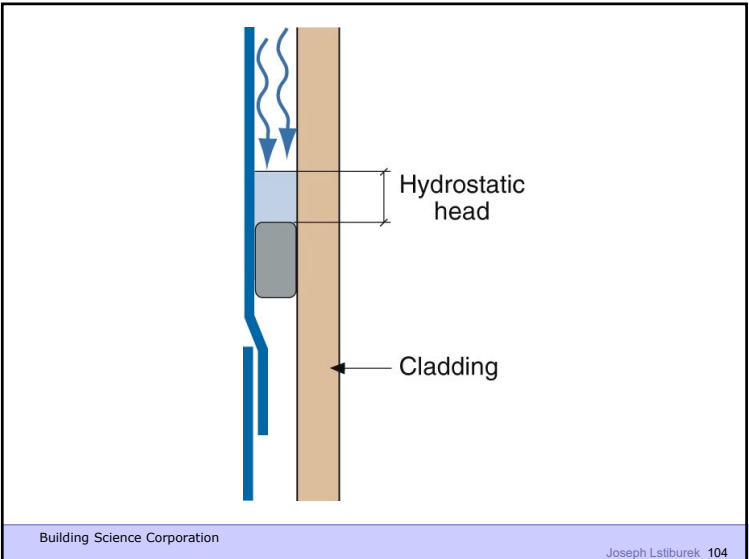

104

Building Science Corporation

Joseph Lstiburek 104

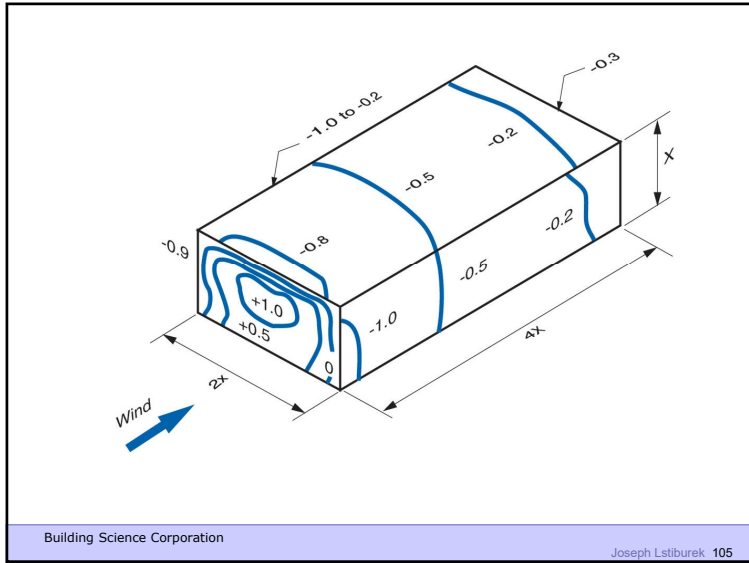

105

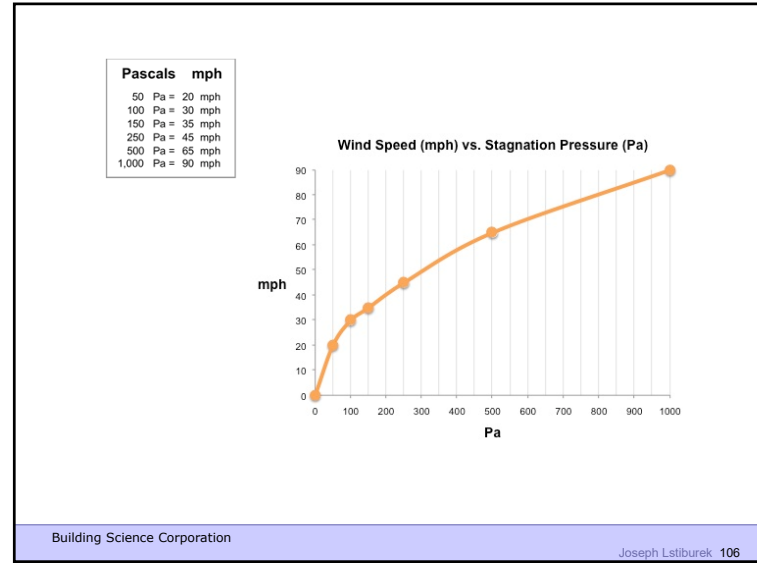

106



107

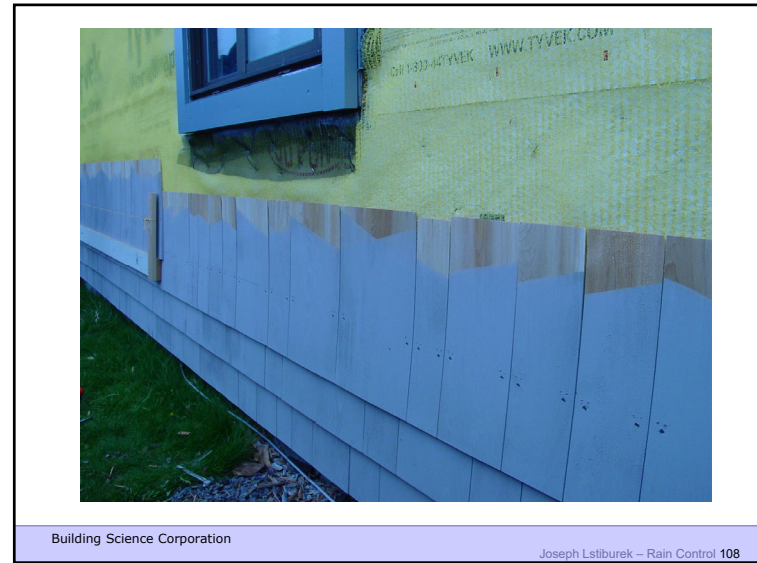

108



Building Science Corporation

Joseph Lstiburek 109

109



Building Science Corporation

Joseph Lstiburek 110

110

EIFS No Longer Has Issues

Building Science Corporation

Joseph Lstiburek 111

111

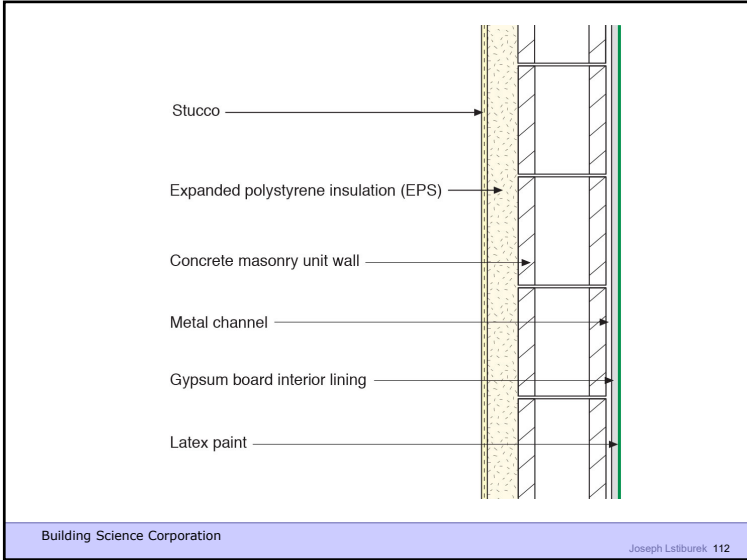

Building Science Corporation

Joseph Lstiburek 112

112

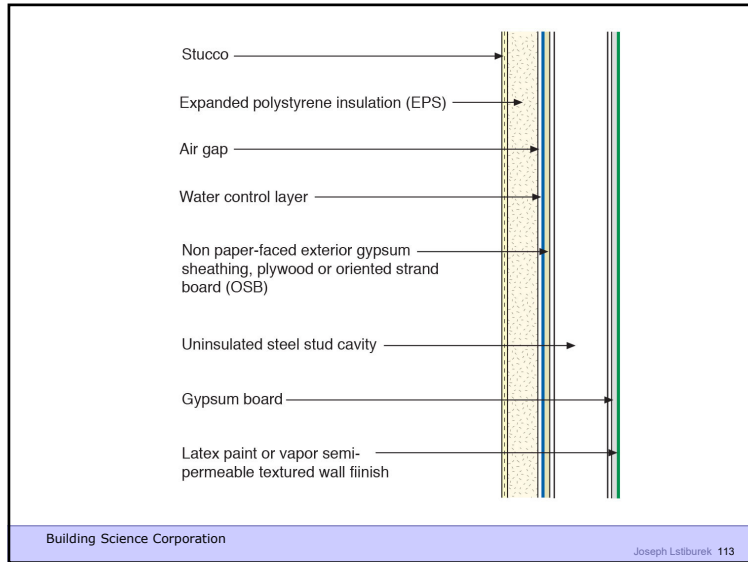

113

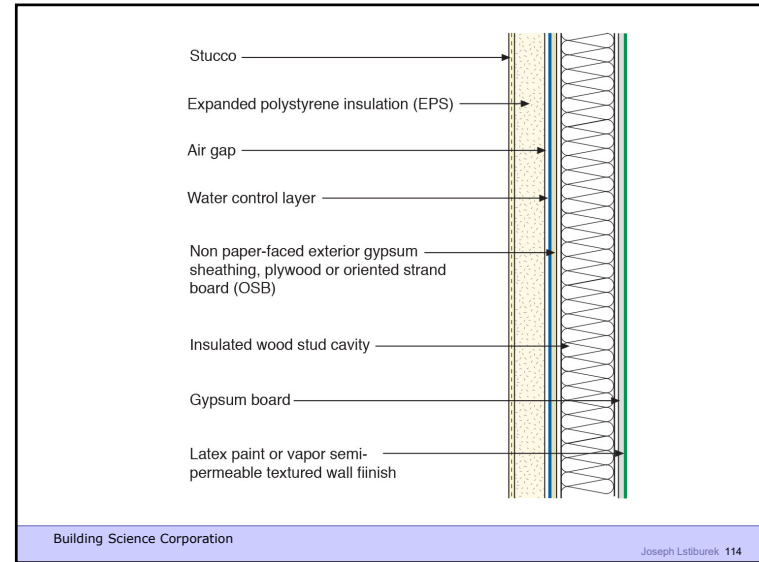

114

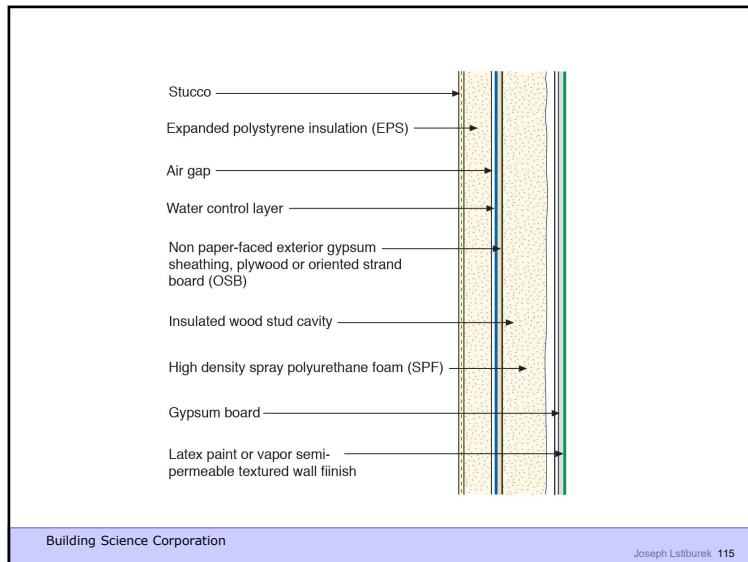

115

Back To Stucco....

Building Science Corporation Joseph Lstiburek 116

116

Lime vs Portland Cement
Polymer Modification

Building Science Corporation Joseph Lstiburek 117

117

Traditional Lime Stucco	Greater than 20 perms
Lime/Portland Cement Stucco	5 to 10 perms
Portland Cement Stucco	1 to 5 perms
Polymer Modification	Less than 1

Building Science Corporation Joseph Lstiburek 118

118

← Increasing Permeance

Scratch Coat
Brown Coat
Finish Coat

Building Science Corporation Joseph Lstiburek 119

119

Horizontal "scoring"
provides mechanical
bond and "shelf"
for water during "wet" curing

Building Science Corporation Joseph Lstiburek 120

120

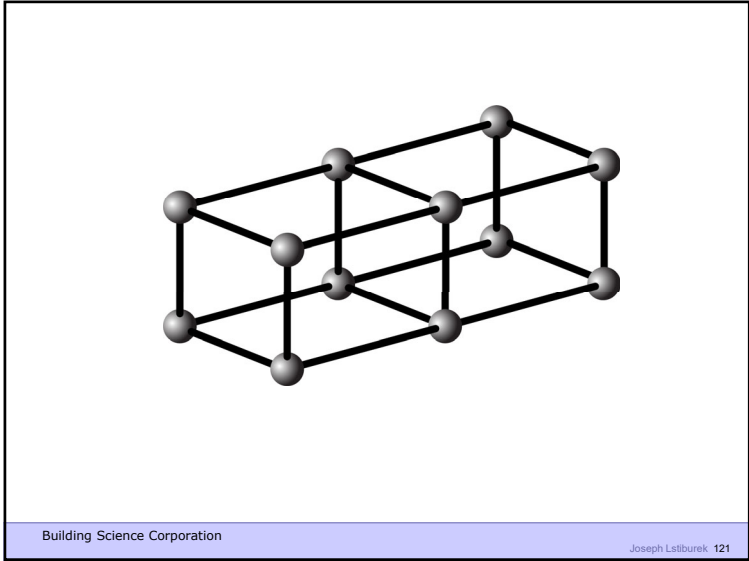

121

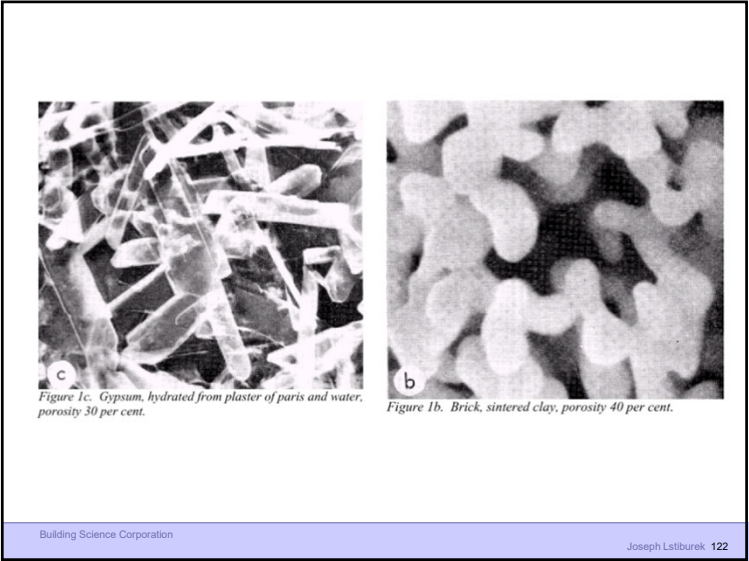

122

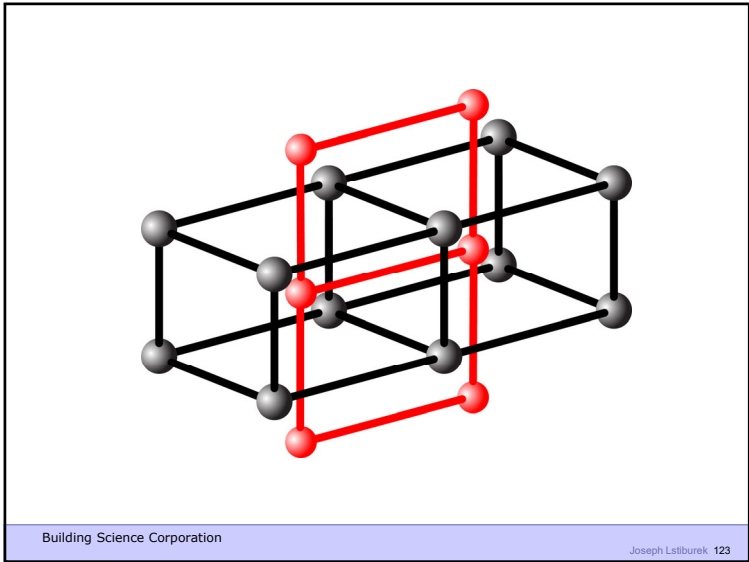

123

Non Traditional Building Wraps

Building Science Corporation Joseph Lstiburek 124

124

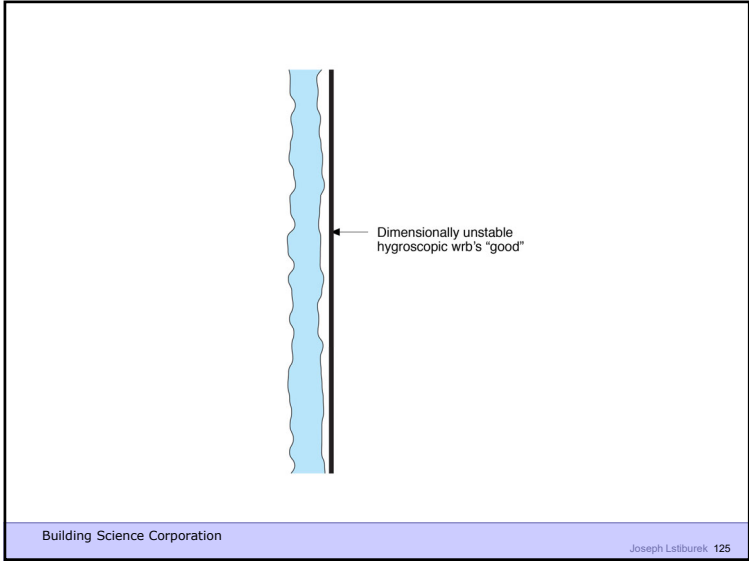

125

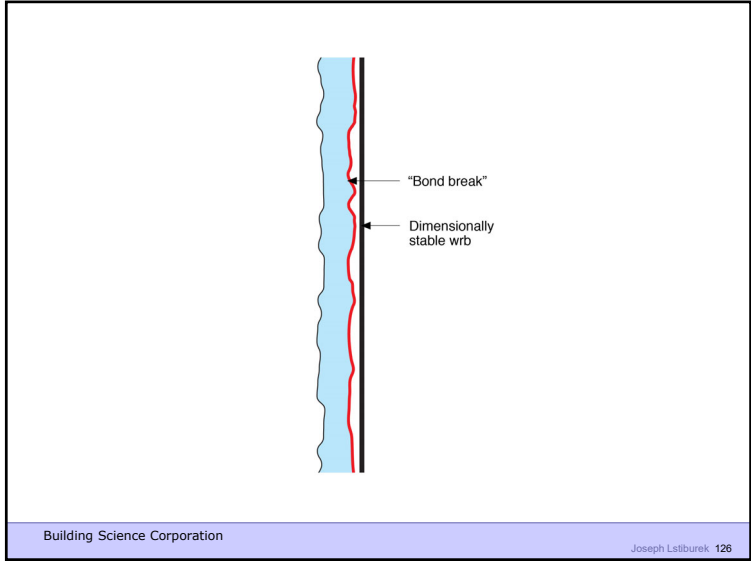

126

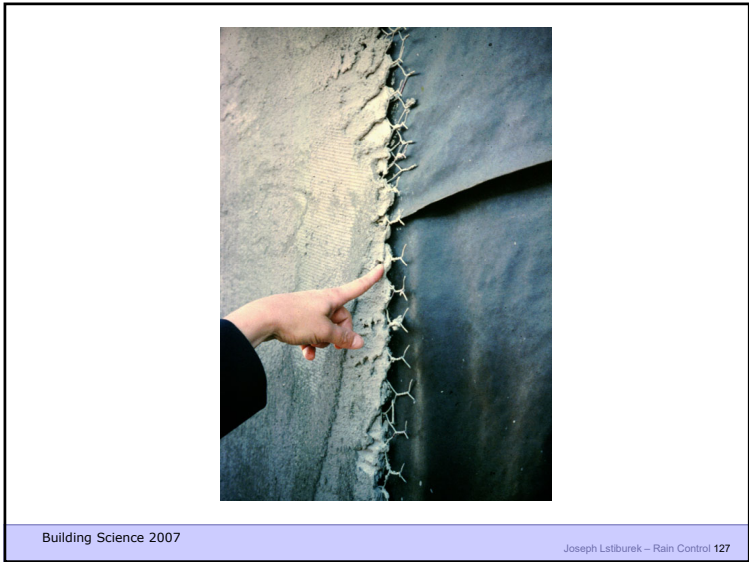

127

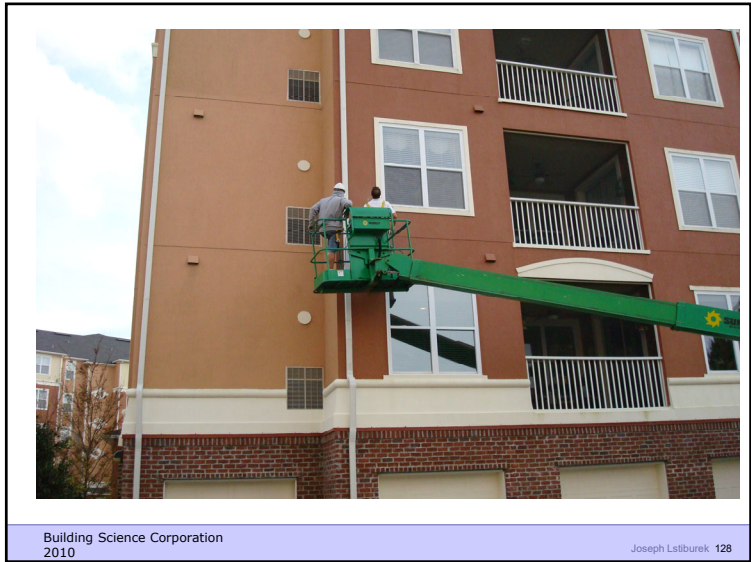

128

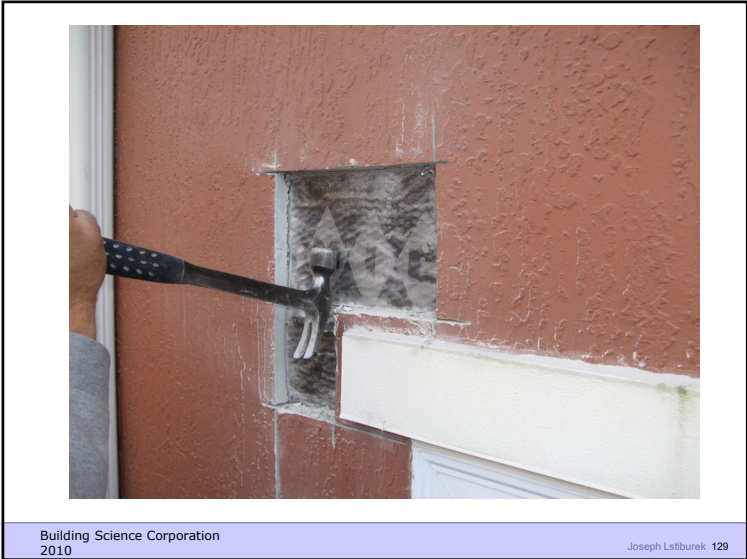

Building Science Corporation
2010

Joseph Lstiburek 129

129



Building Science 2007

Joseph Lstiburek - Rain Control 130

130



Building Science Corporation

Joseph Lstiburek 131

131



Building Science Corporation

Joseph Lstiburek 132

132

Side Trip To My Backyard....

Building Science Corporation

Joseph Lstiburek 133

133



Building Science 2007

Joseph Lstiburek – Rain Control 134

134

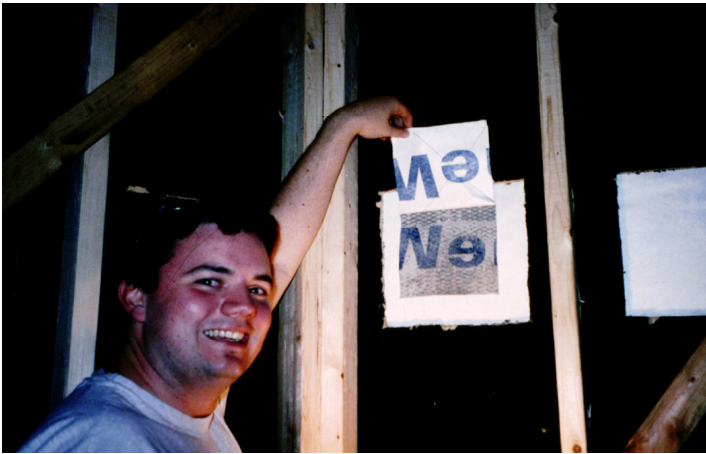

Building Science 2007

Joseph Lstiburek – Rain Control 135

135



Building Science 2007

Joseph Lstiburek – Rain Control 136

136



137



138



139

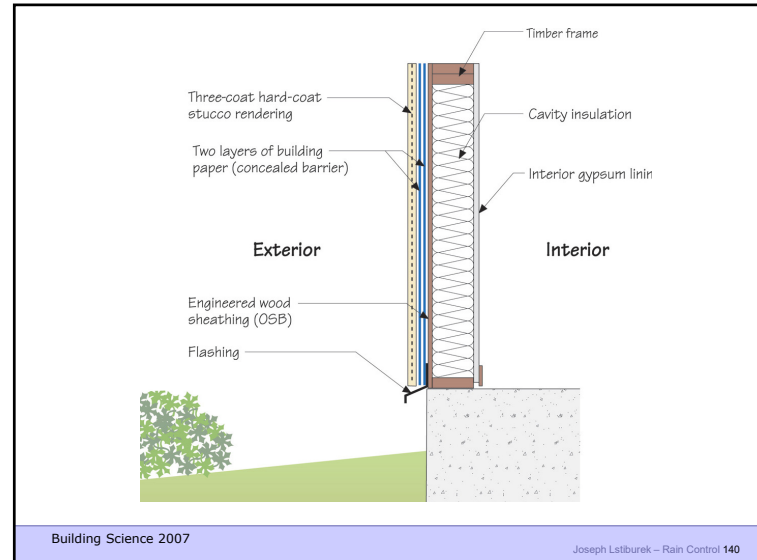

140

“Lumpy Stucco”....
Should Have Been The Big US Warning....

Building Science Corporation

Joseph Lstiburek 141

141



Building Science 2007

Joseph Lstiburek – Rain Control 142

142



Building Science 2007

Joseph Lstiburek – Rain Control 143

143



Building Science 2007

Joseph Lstiburek – Rain Control 144

144

Back To America....Pennsylvania....
And Then Pretty Much Anywhere It Rains...

Building Science Corporation

Joseph Lstiburek 145

145



Building Science Corporation

Joseph Lstiburek 146

146



Building Science Corporation

Joseph Lstiburek 147

147



Building Science Corporation

Joseph Lstiburek 148

148

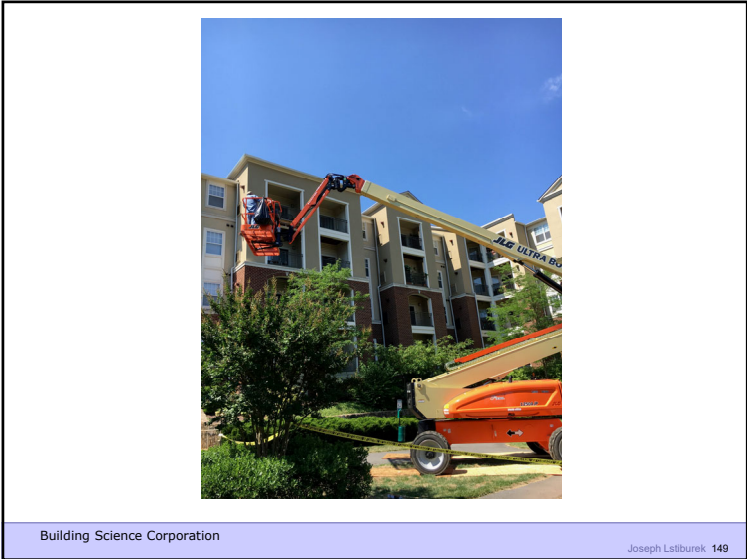

Building Science Corporation

Joseph Lstiburek 149

149

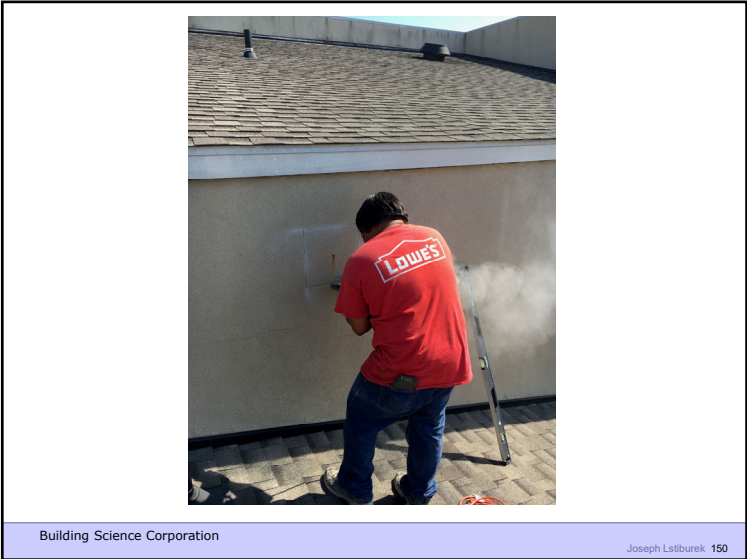

Building Science Corporation

Joseph Lstiburek 150

150



Building Science Corporation

Joseph Lstiburek 151

151



Building Science Corporation

Joseph Lstiburek 152

152

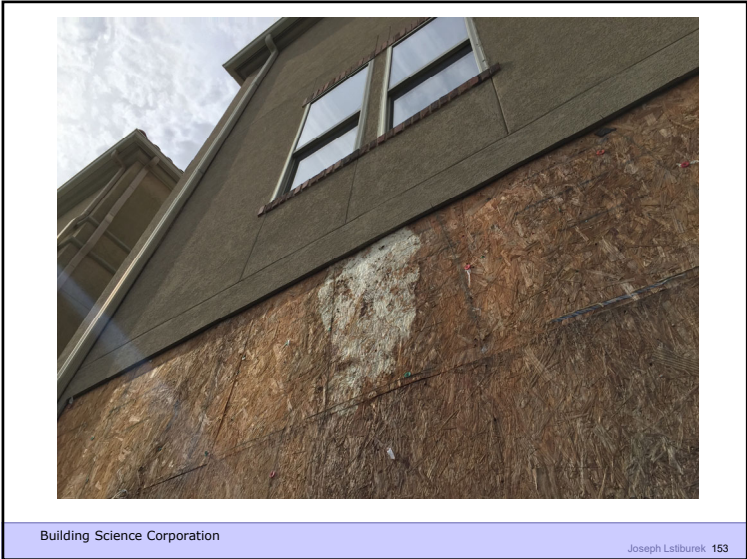

Building Science Corporation

Joseph Lstiburek 153

153

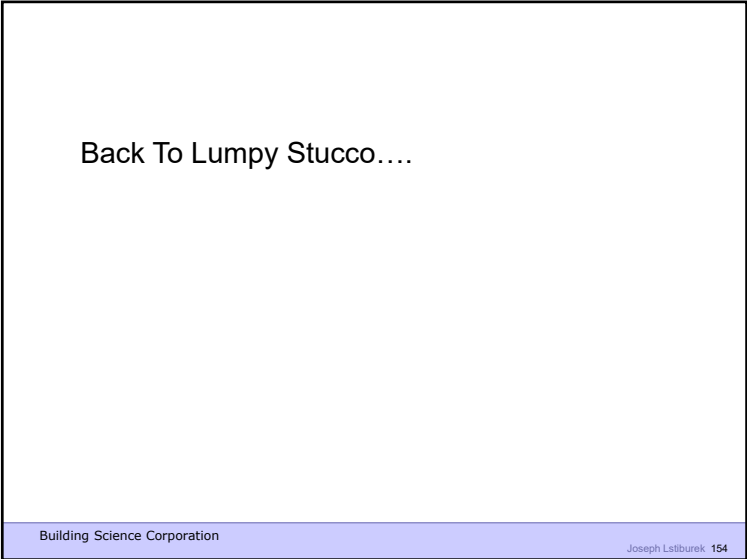

Building Science Corporation

Joseph Lstiburek 154

154



Building Science Corporation

Joseph Lstiburek 155

155



Building Science Corporation

Joseph Lstiburek 156

156

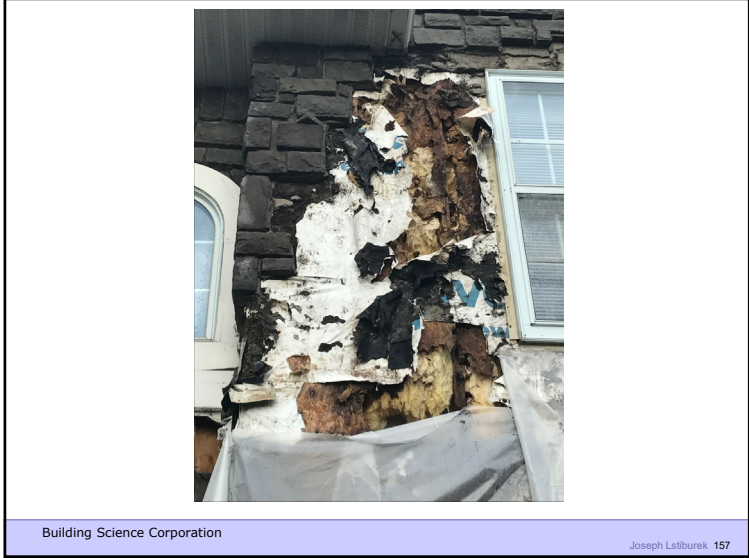

Building Science Corporation

Joseph Lstiburek 157

157



Building Science Corporation

Joseph Lstiburek 158

158

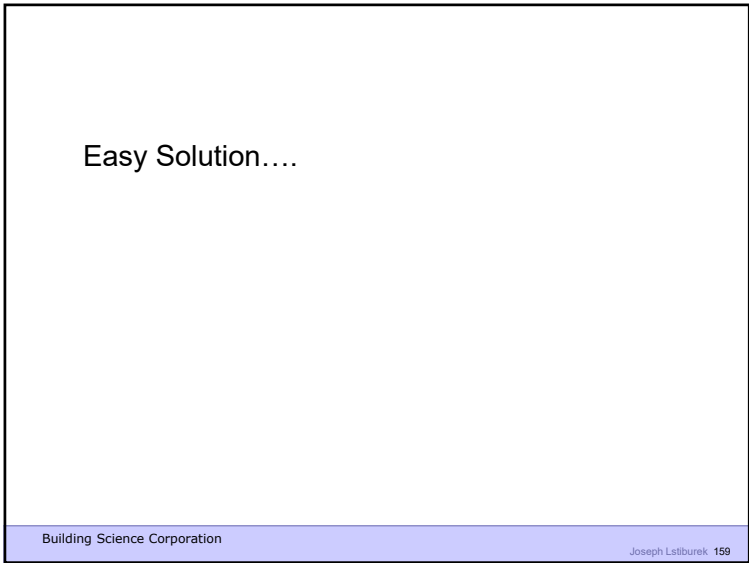

Building Science Corporation

Joseph Lstiburek 159

159

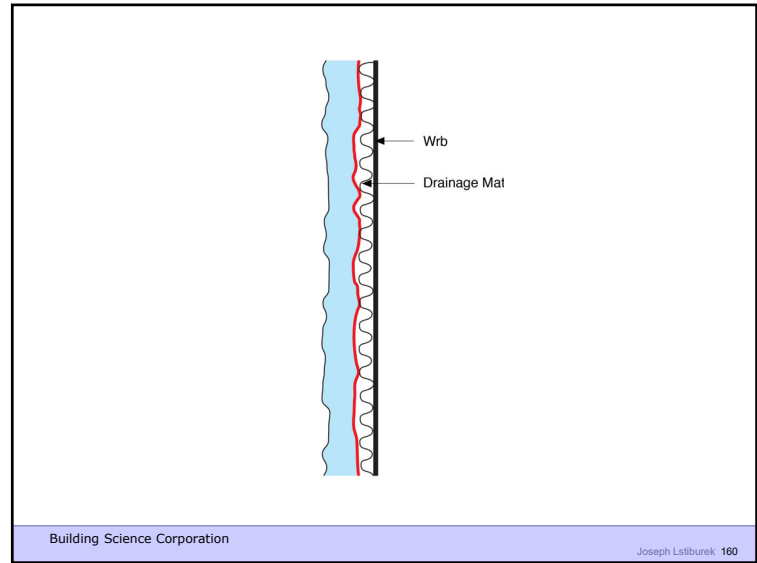

Building Science Corporation

Joseph Lstiburek 160

160

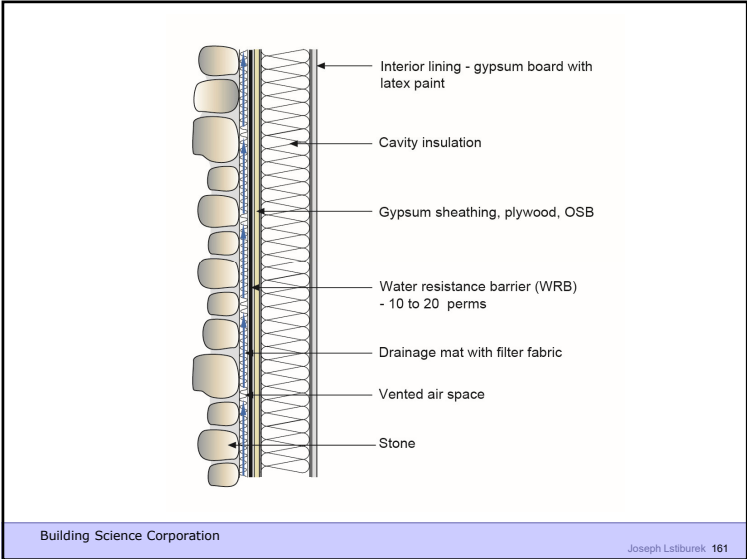

161