

Joseph Lstiburek, Ph.D., P.Eng, ASHRAE Fellow

Building Science

HVAC Systems

presented by www.buildingscience.com

Don't Do Stupid Things

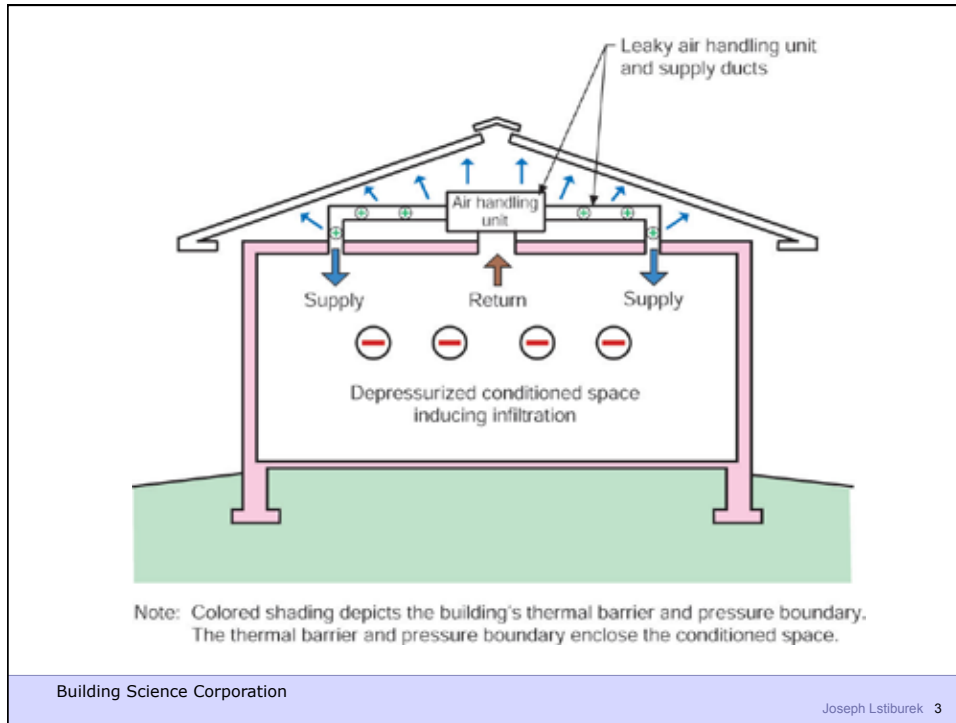



Building Science Corporation

Joseph Lstiburek 5



Building Science Corporation

Joseph Lstiburek 6

Duct Leakage Should Be Less Than 5% of Rated Flow As Tested By Pressurization To 25 Pascals

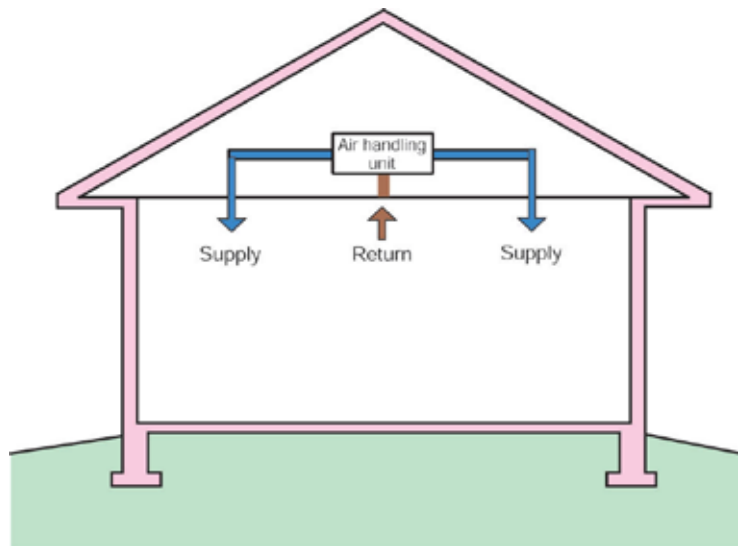

Note: Colored shading depicts the building's thermal barrier and pressure boundary. The thermal barrier and pressure boundary enclose the conditioned space.

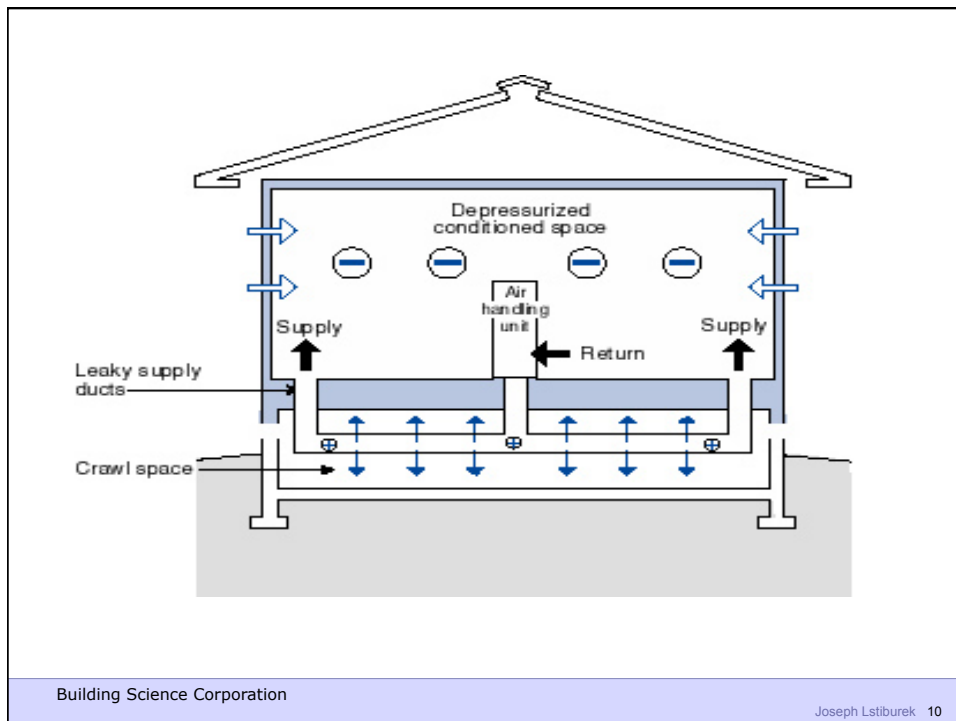
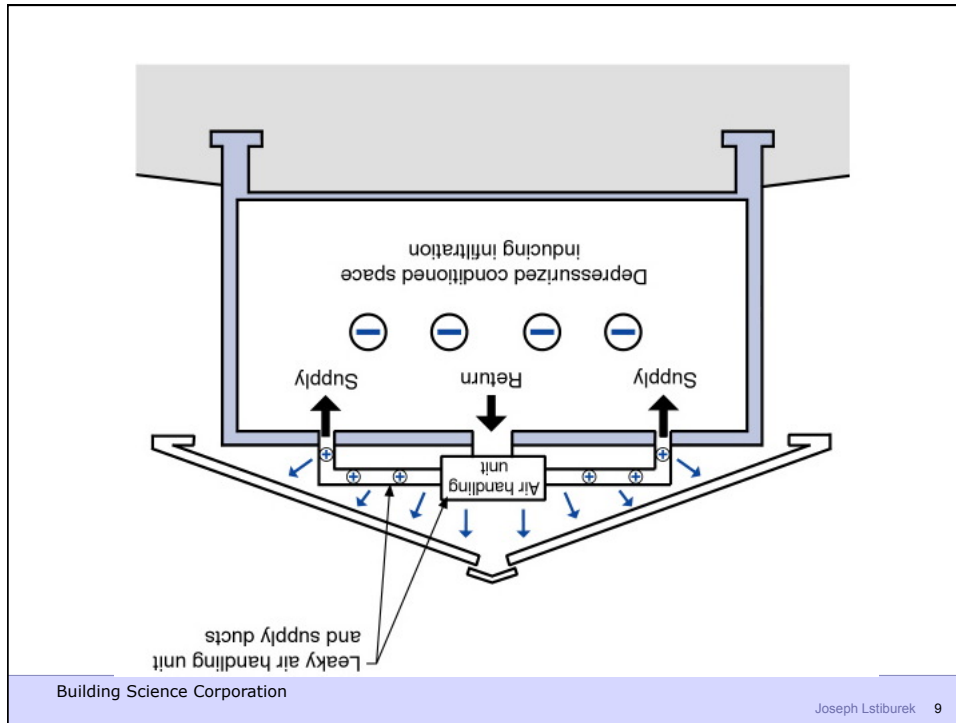

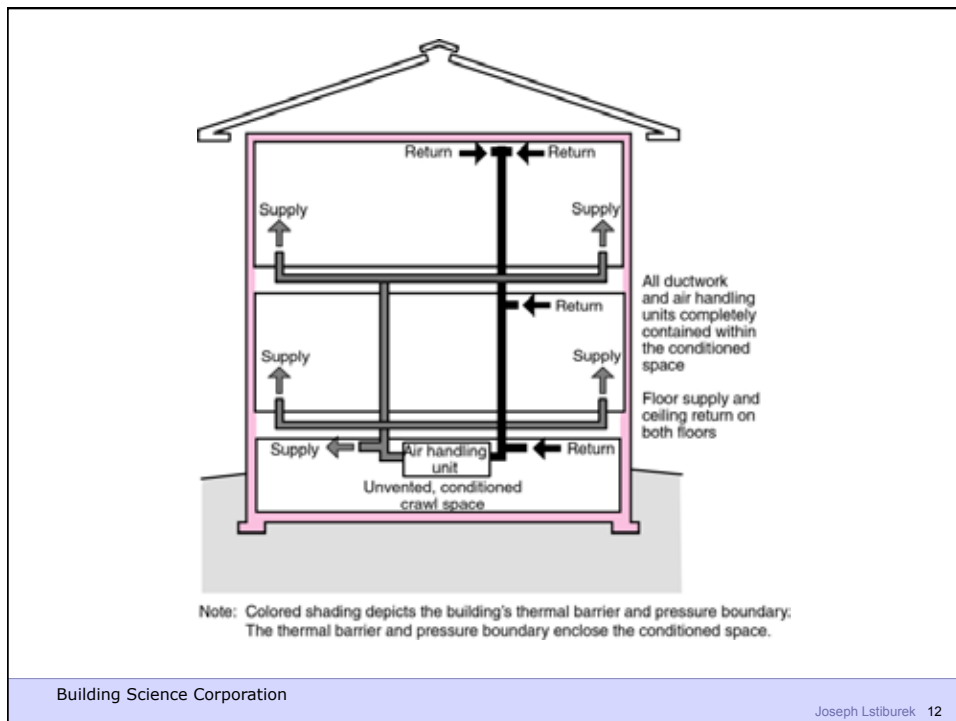
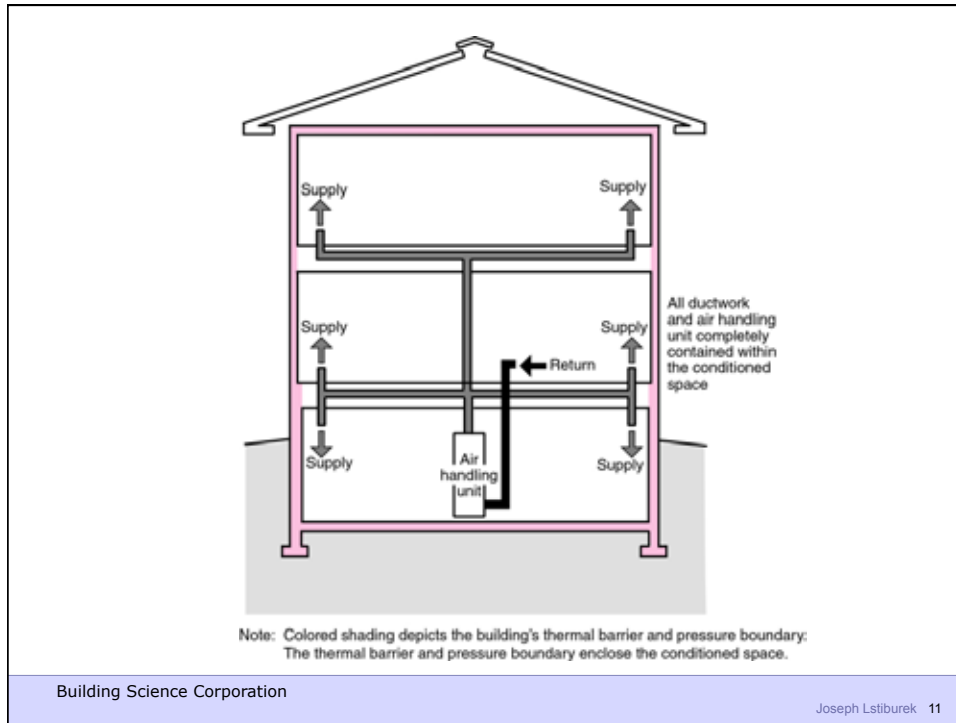

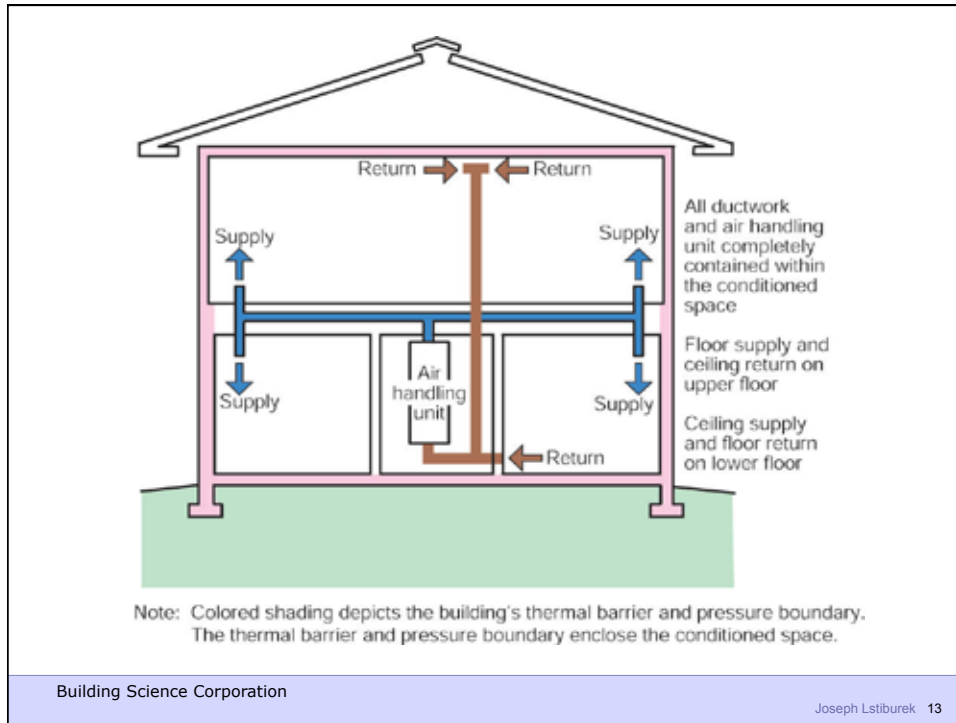

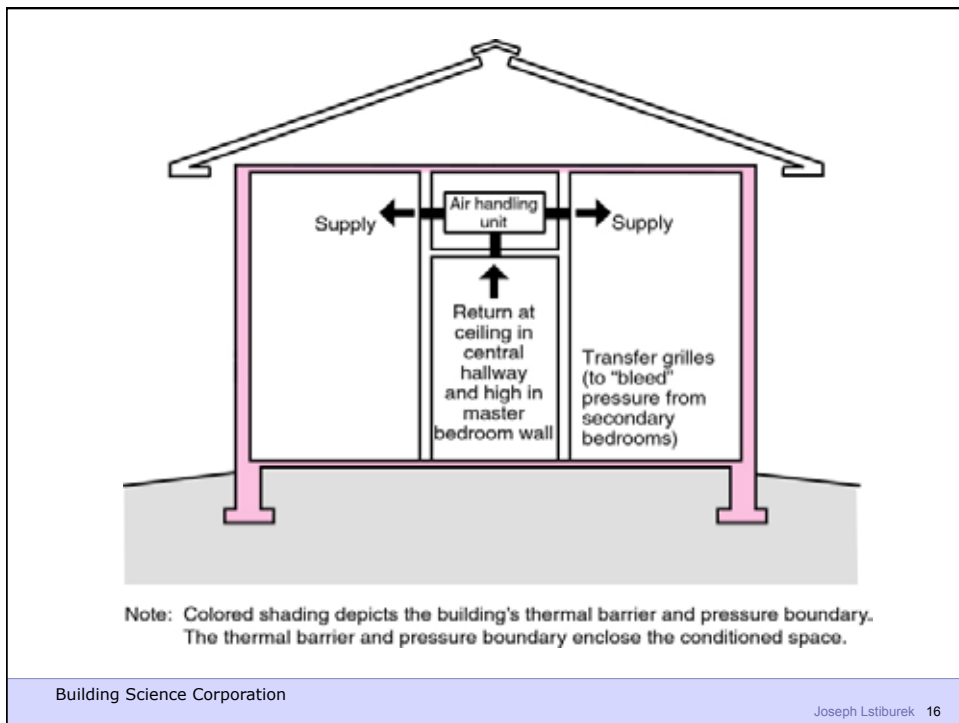
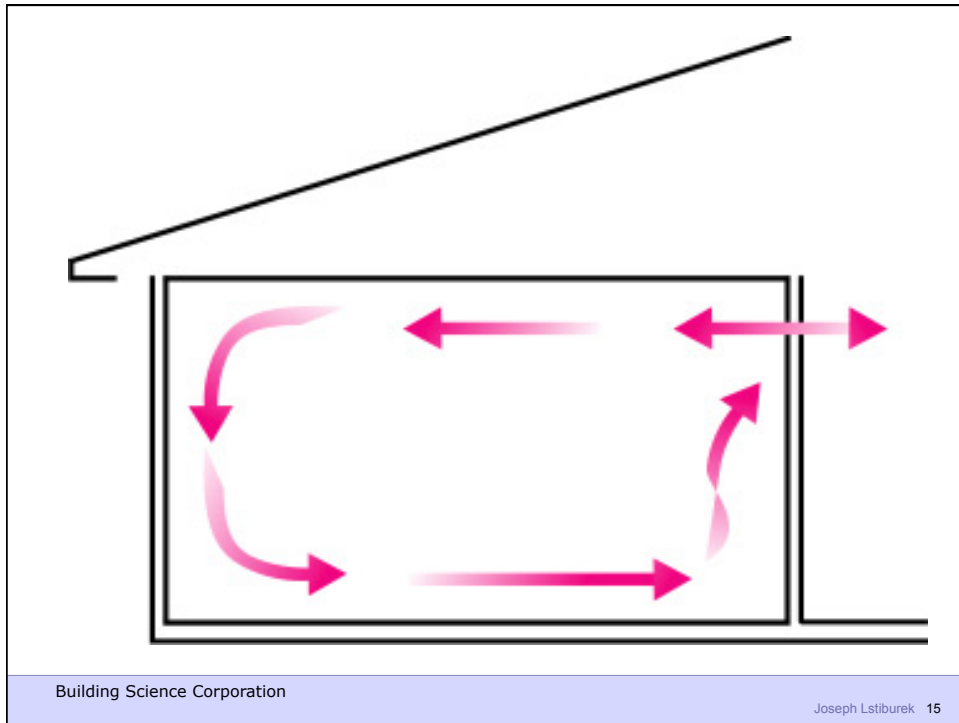

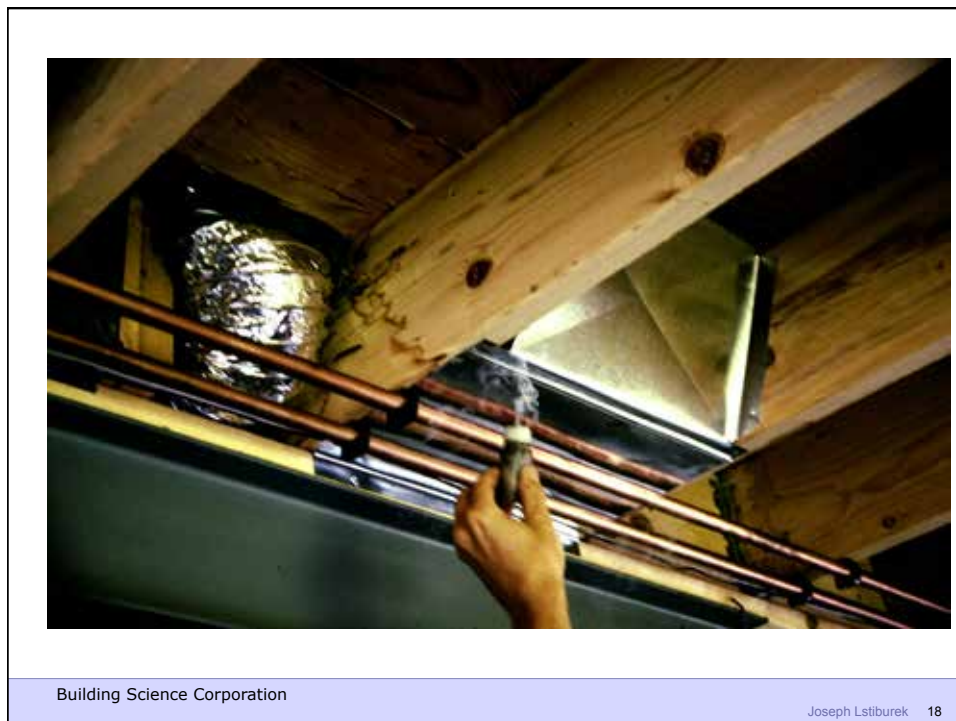
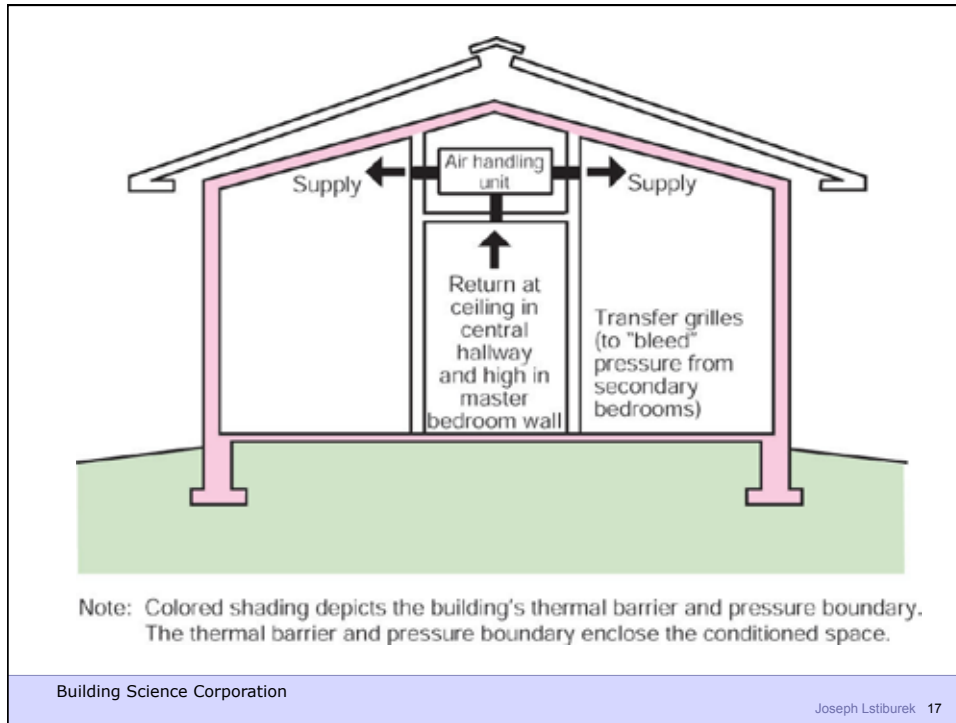



Building Science Corporation

Joseph Lstiburek 19



Building Science Corporation

Joseph Lstiburek 20



Building Science Corporation



Building Science Corporation



Building Science Corporation

Joseph Lstiburek 23



Building Science Corporation

Joseph Lstiburek 24

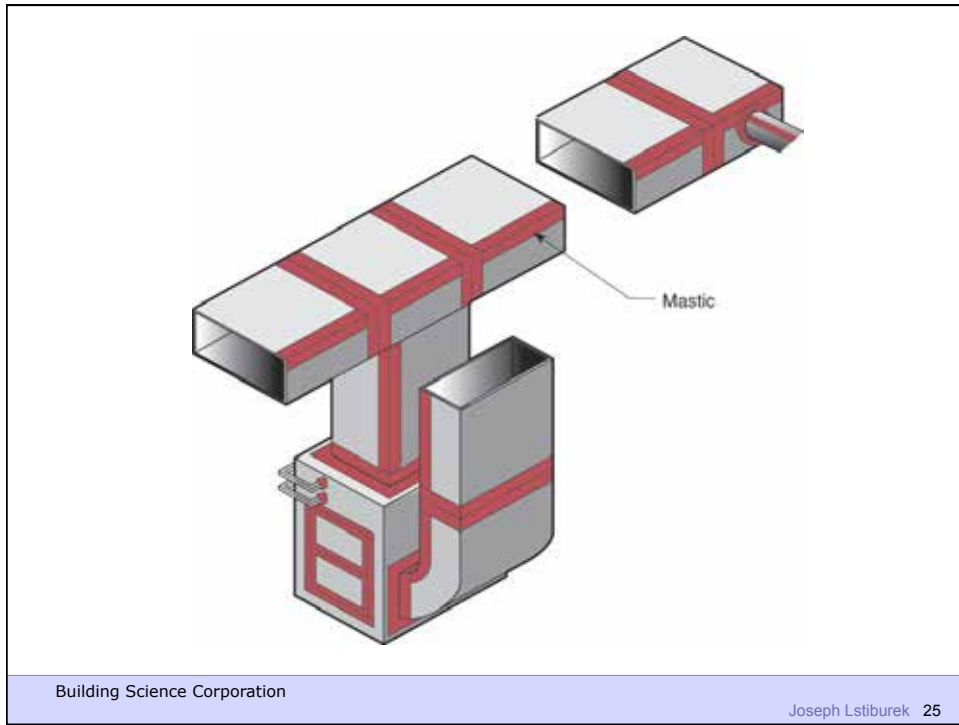



Building Science Corporation

Joseph Lstiburek 27

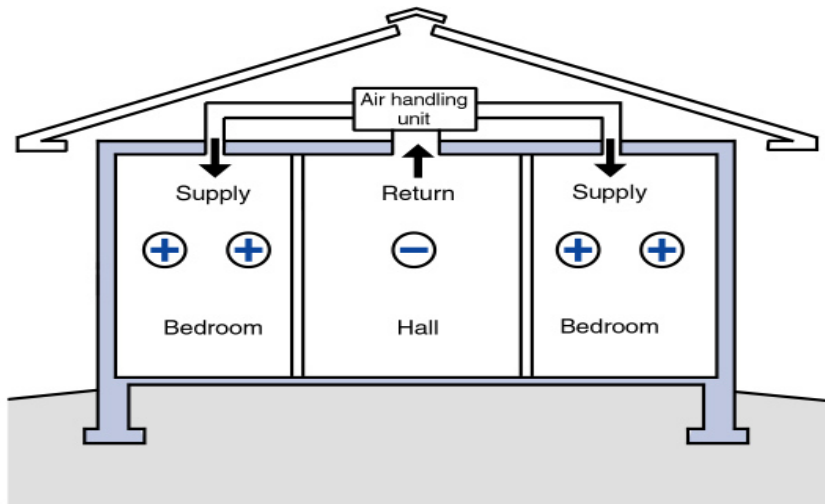

Building Science Corporation

Joseph Lstiburek 28



Building Science Corporation

Joseph Lstiburek 29



Building Science Corporation

Joseph Lstiburek 30



Building Science Corporation

Joseph Lstiburek 31



Building Science Corporation

Joseph Lstiburek 32



Building Science Corporation

Joseph Lstiburek 33

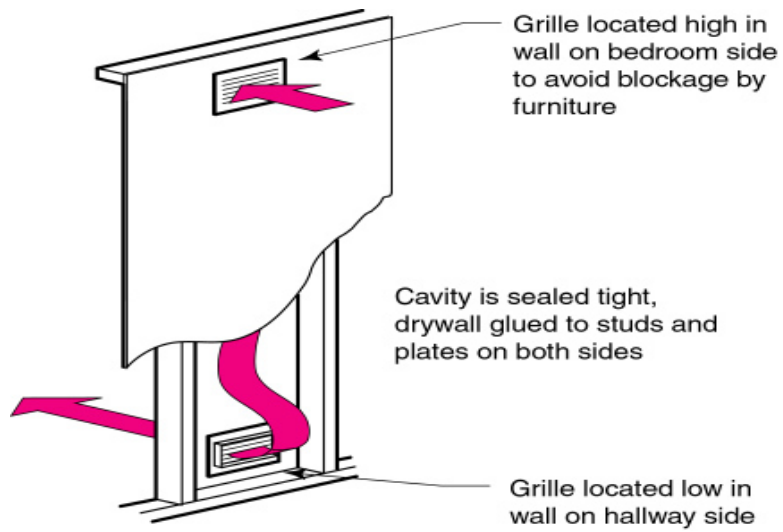

Building Science Corporation

Joseph Lstiburek 34



Building Science Corporation



Building Science Corporation

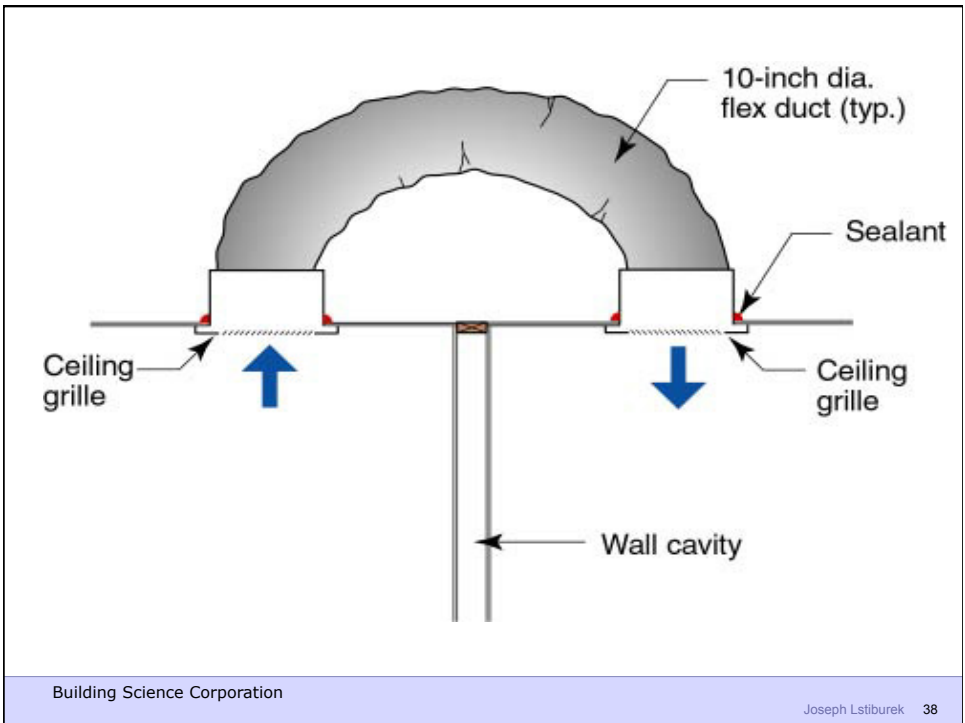

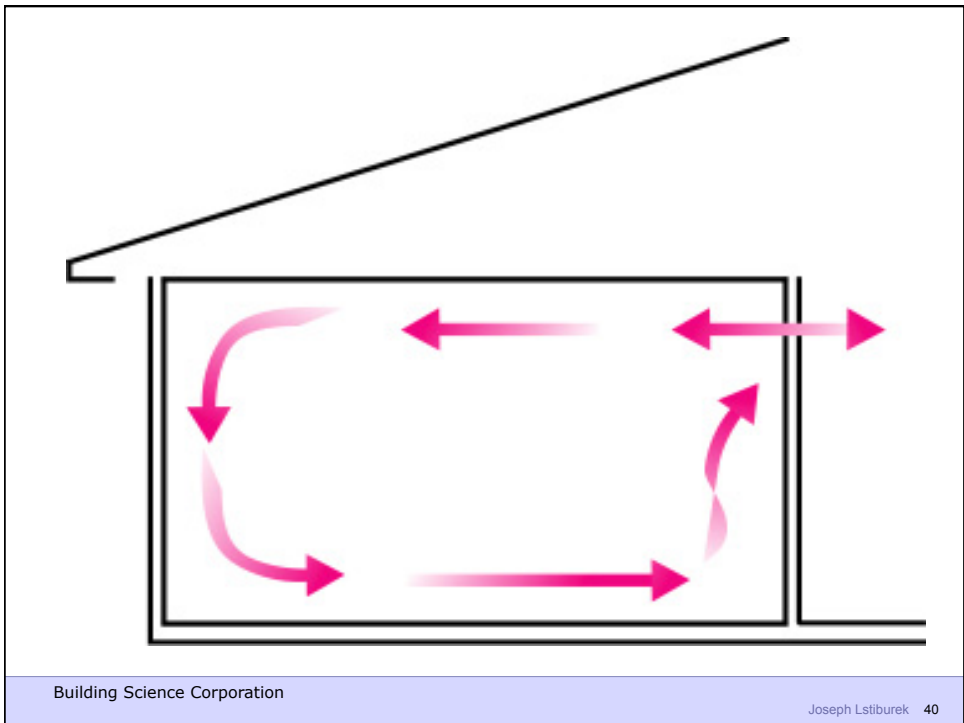



Building Science Corporation

Joseph Lstiburek 41

Build Tight - Ventilate Right

Building Science Corporation

Joseph Lstiburek 42

Build Tight - Ventilate Right How Tight? What's Right?

Building Science Corporation

Joseph Lstiburek 43

Three Types of Controlled Ventilation Systems

Exhaust Ventilation
Supply Ventilation
Balanced Ventilation

Building Science Corporation

Joseph Lstiburek 44

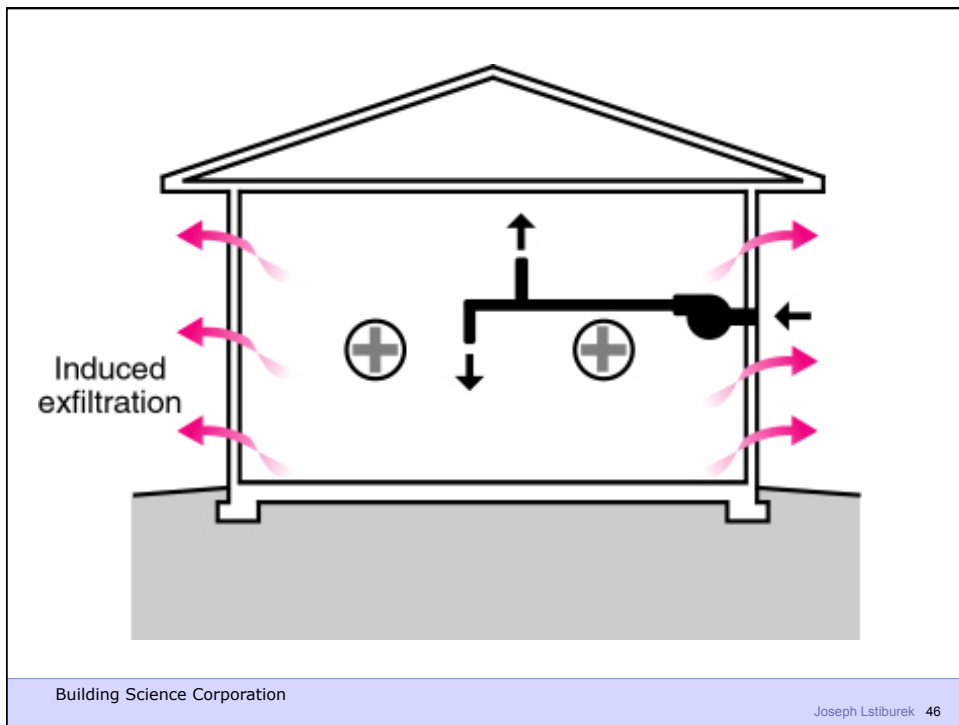
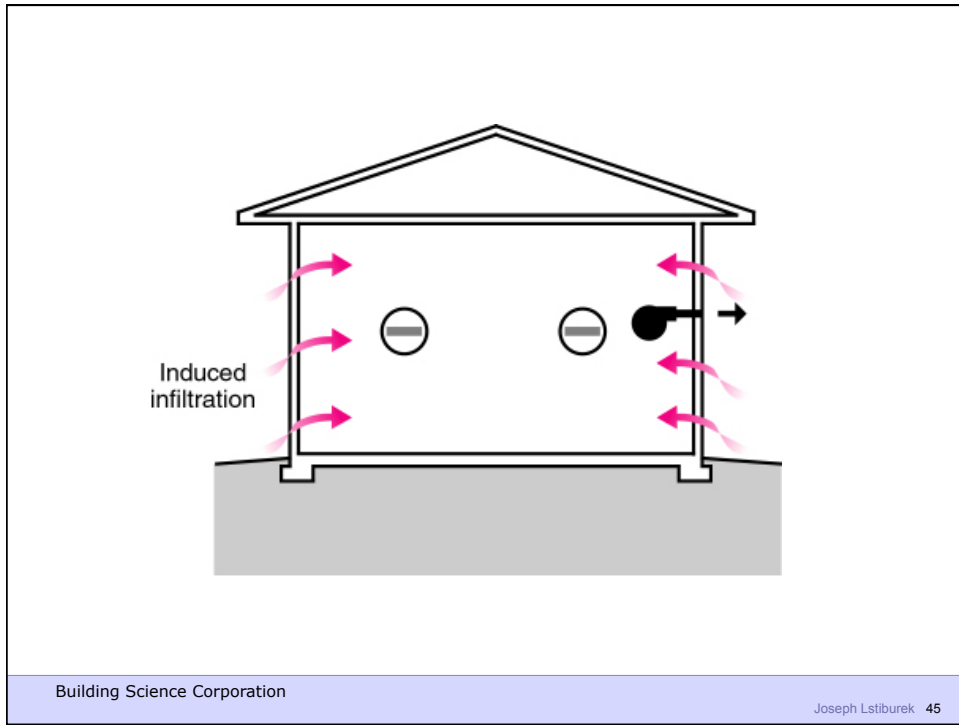

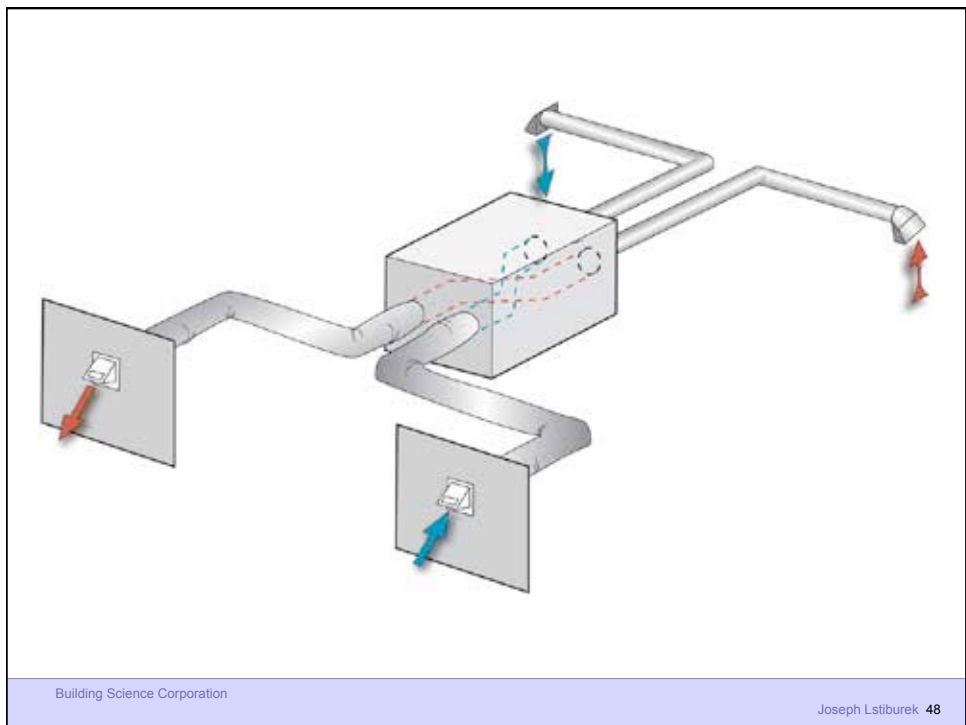
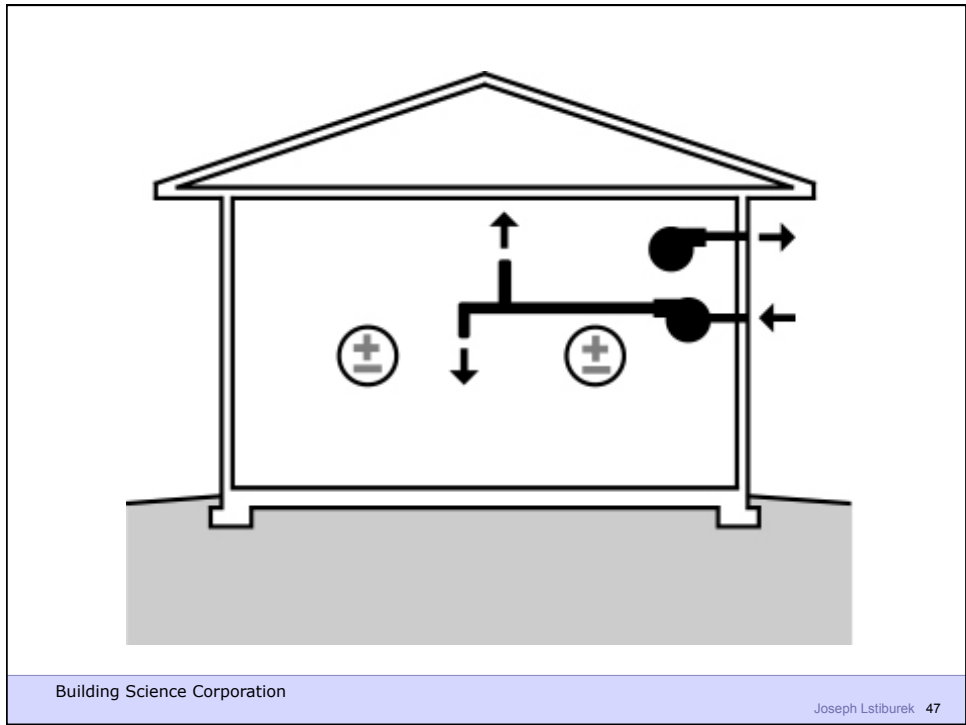

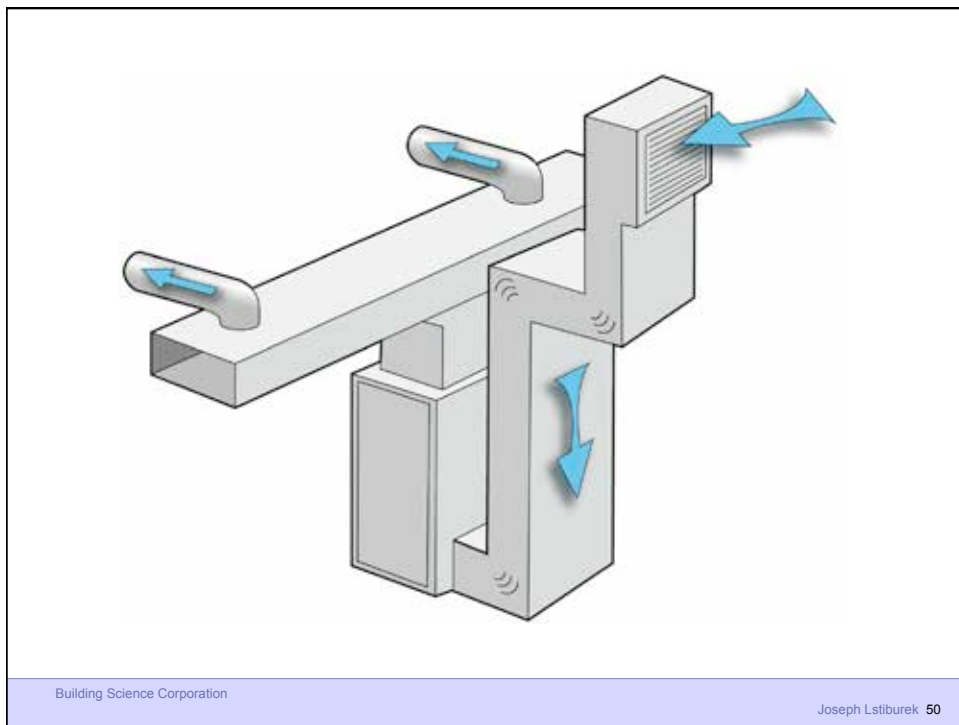
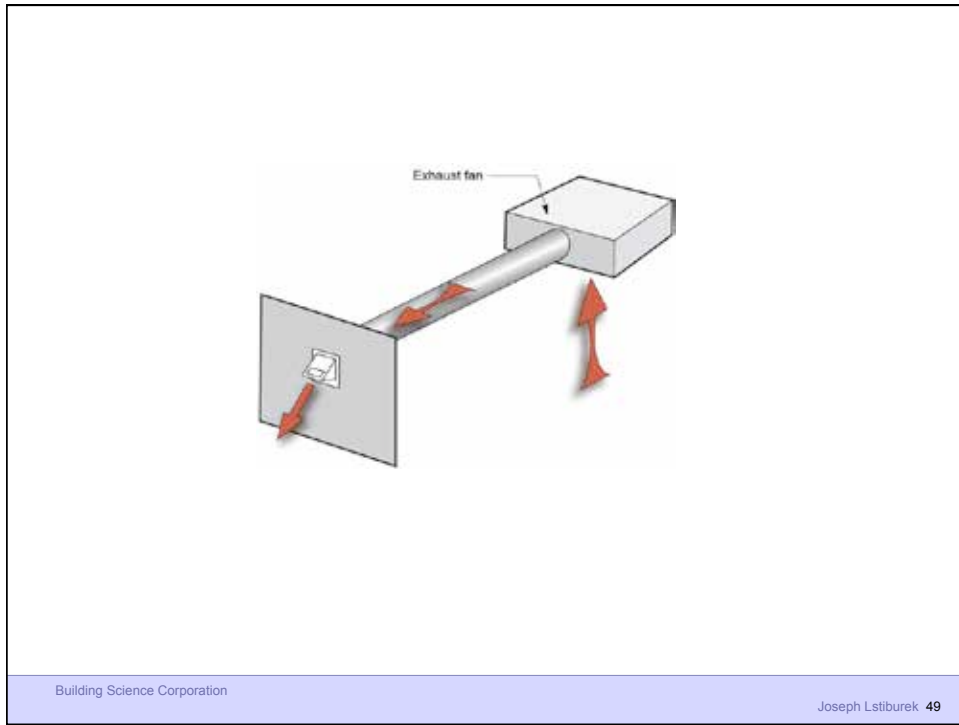

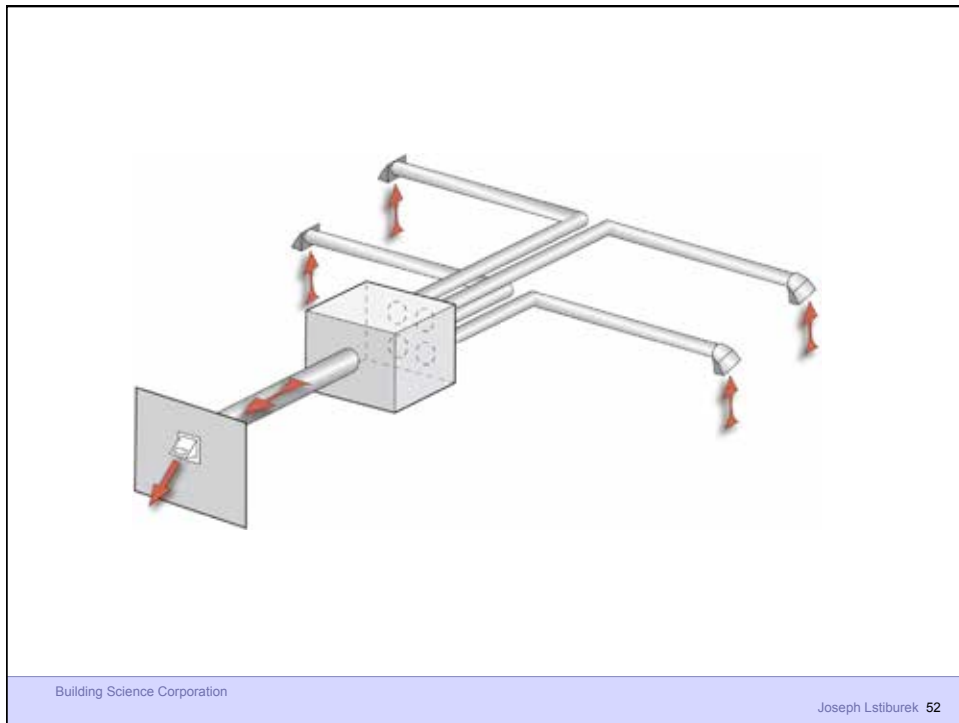
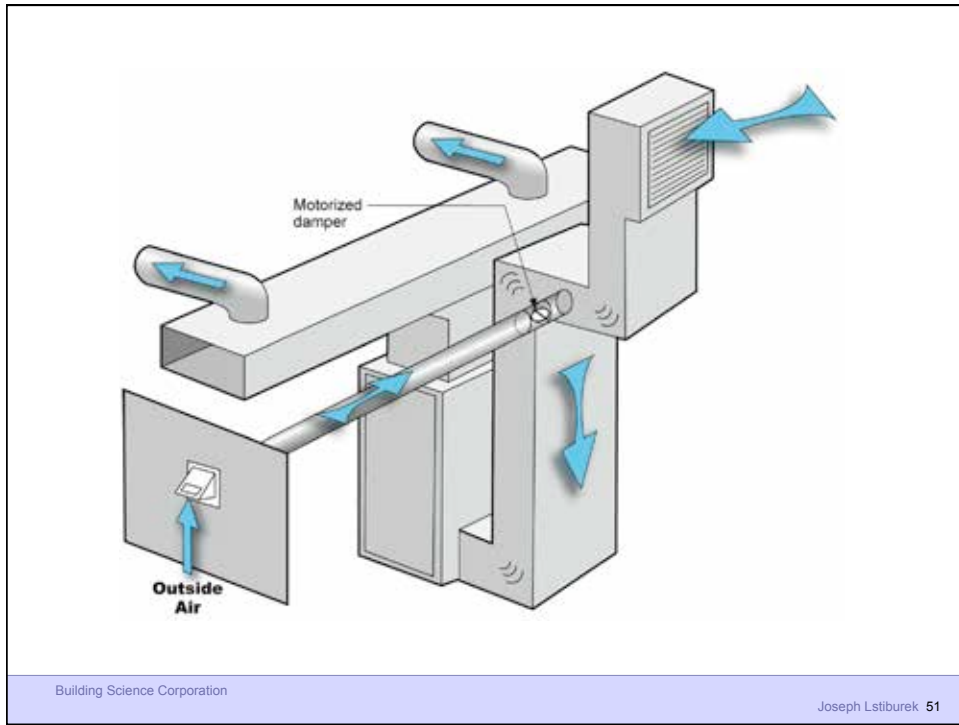

ASHRAE Standard 62.2 calls for 7.5 cfm per person plus 0.03 cfm per square foot of conditioned area

Occupancy is deemed to be the number of bedrooms plus one

ASHRAE Standard 62.2 calls for 7.5 cfm per person plus 0.03 cfm per square foot of conditioned area

Occupancy is deemed to be the number of bedrooms plus one

Outcome is often bad – part load humidity problems, dryness problems, energy problems

Don't Do Stupid Things Humidifiers

Building Science Corporation

Joseph Lstiburek 55

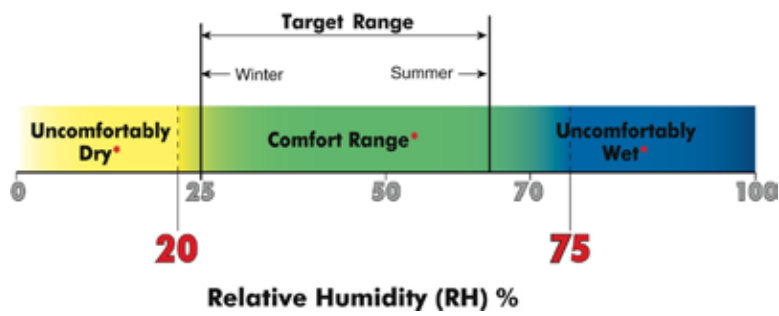

Building Science Corporation

Joseph Lstiburek 56

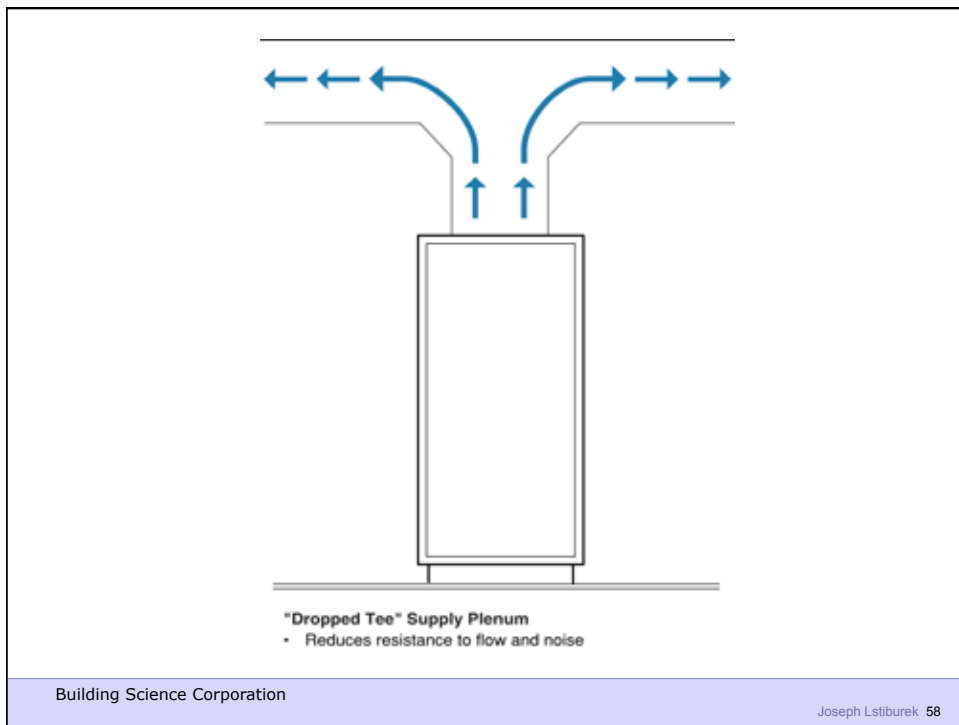
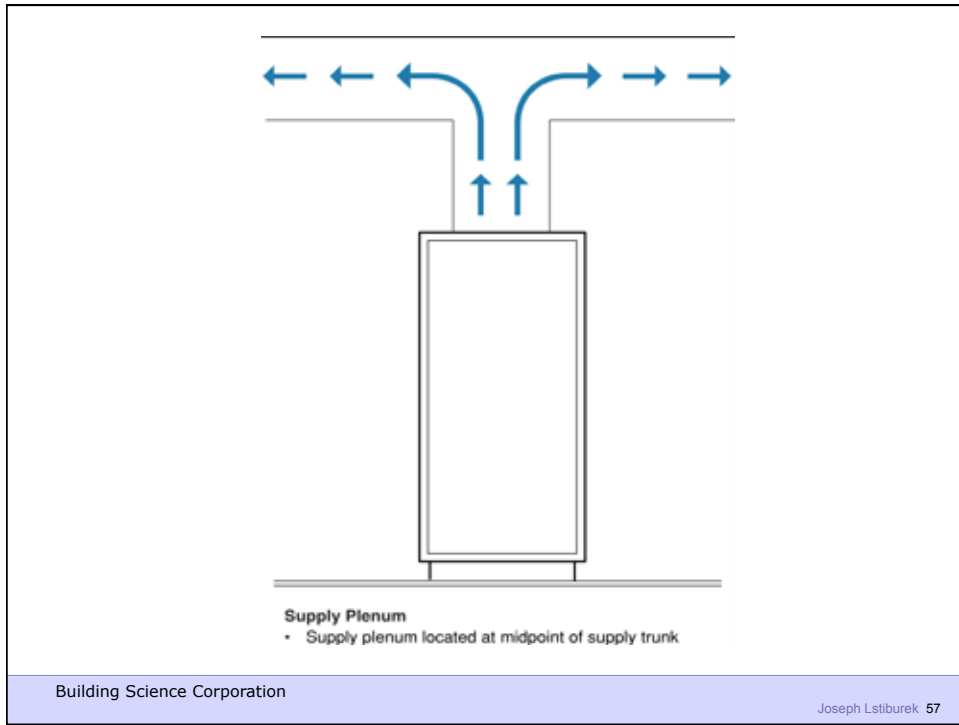

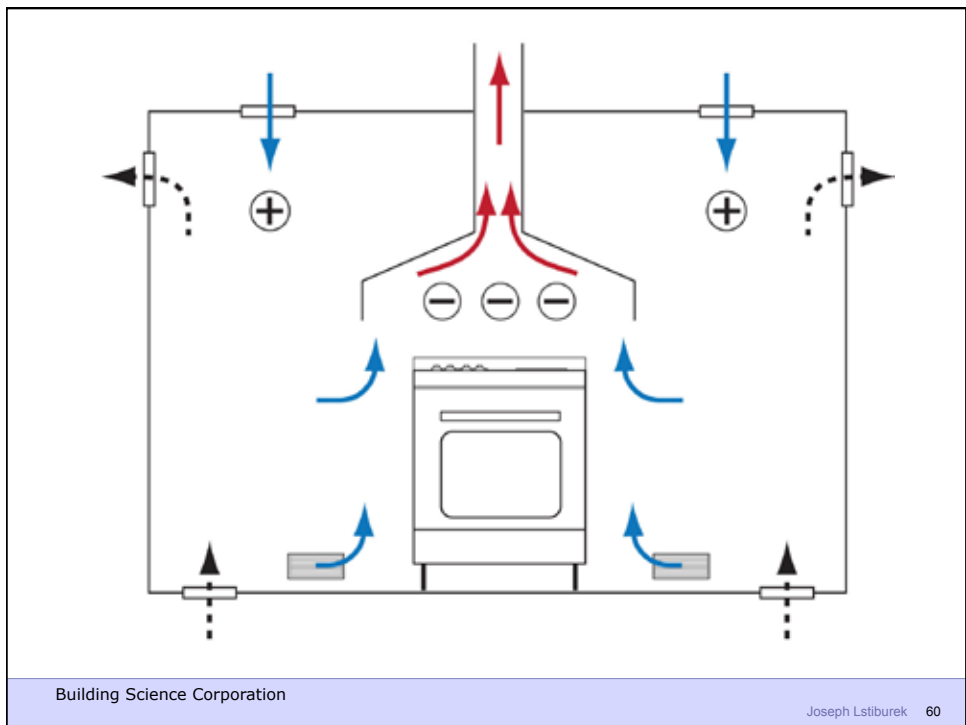
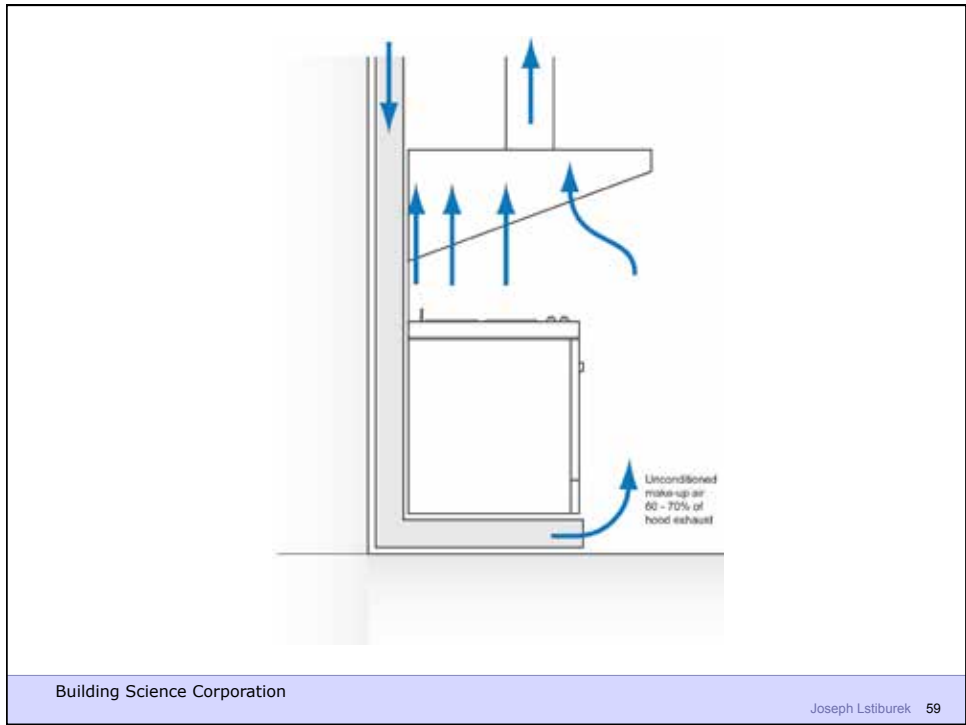

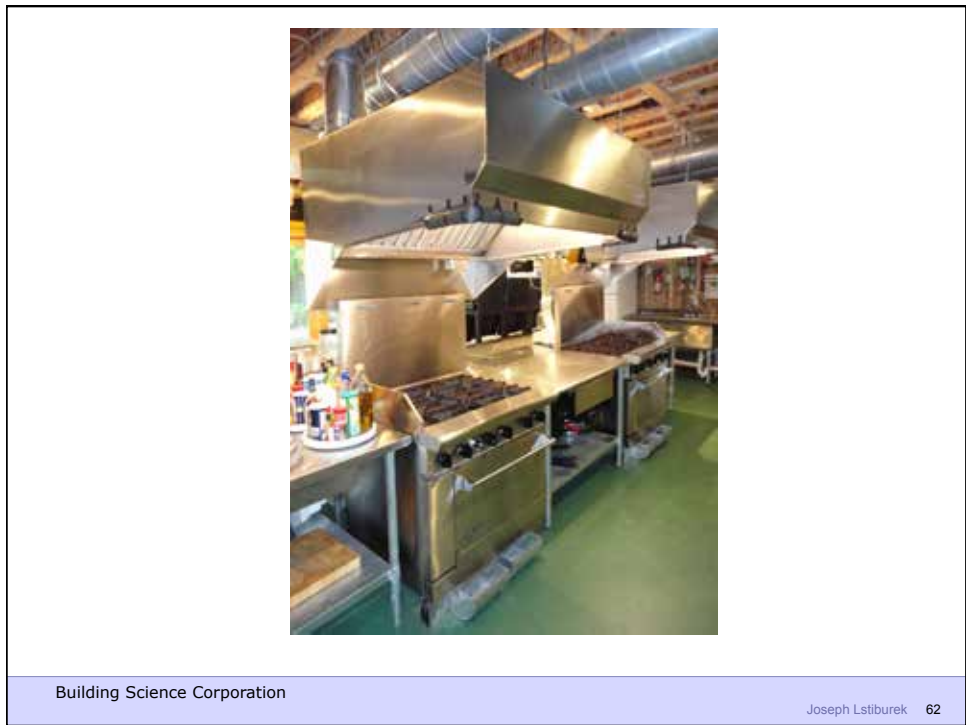
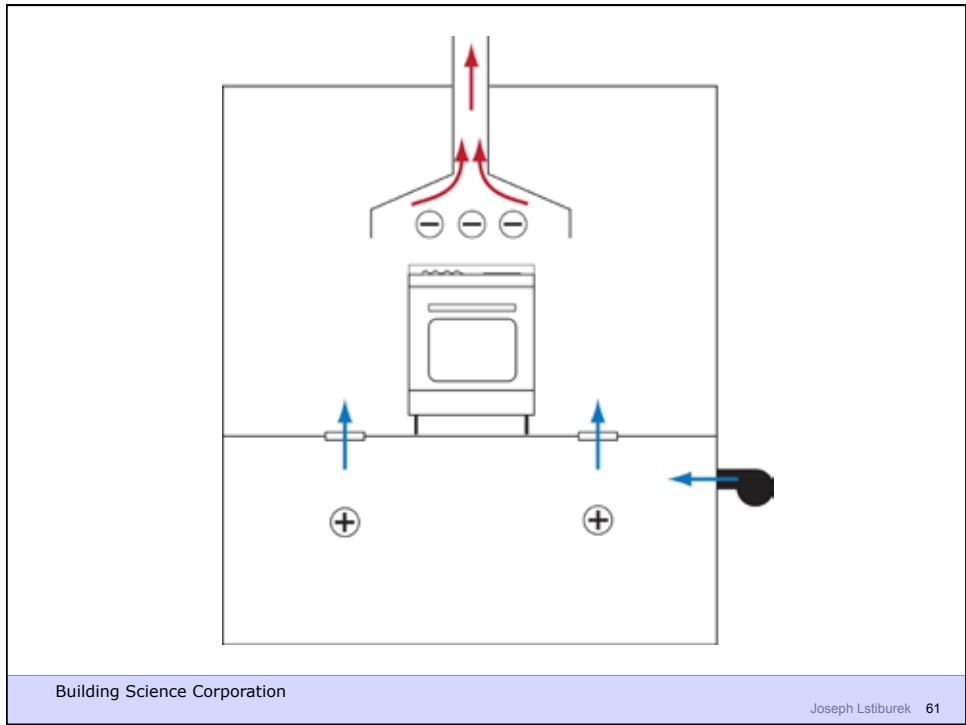



Building Science Corporation

Joseph Lstiburek 63



Building Science Corporation

Joseph Lstiburek 64



Building Science Corporation

Joseph Lstiburek 65



Building Science Corporation

Joseph Lstiburek 66

Joseph Lstiburek, Ph.D., P.Eng, ASHRAE Fellow

Building Science

Rain Control

www.buildingscience.com



Building Science Corporation

Joseph Lstiburek – Rain Control 2



Building Science Corporation

Joseph Lstiburek – Rain Control 3



Building Science Corporation

Joseph Lstiburek – Rain Control 4

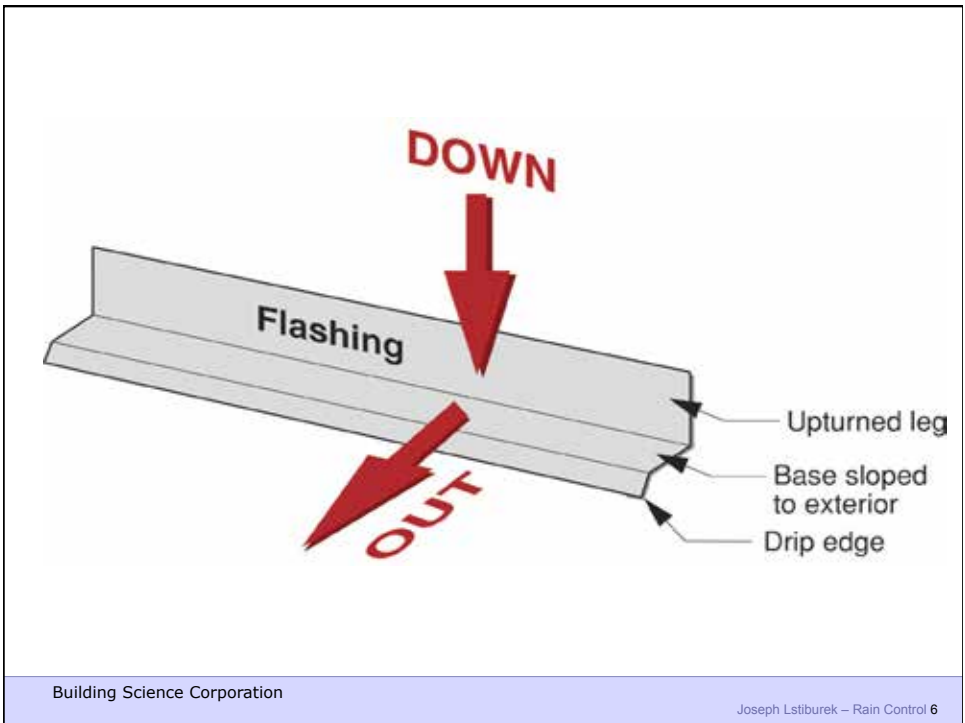

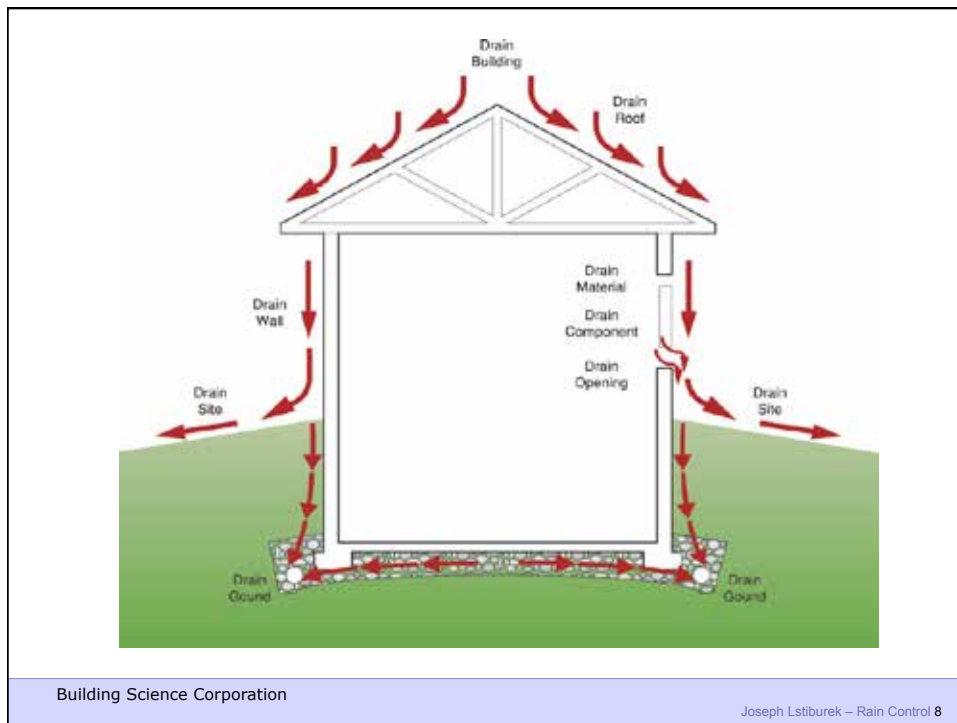
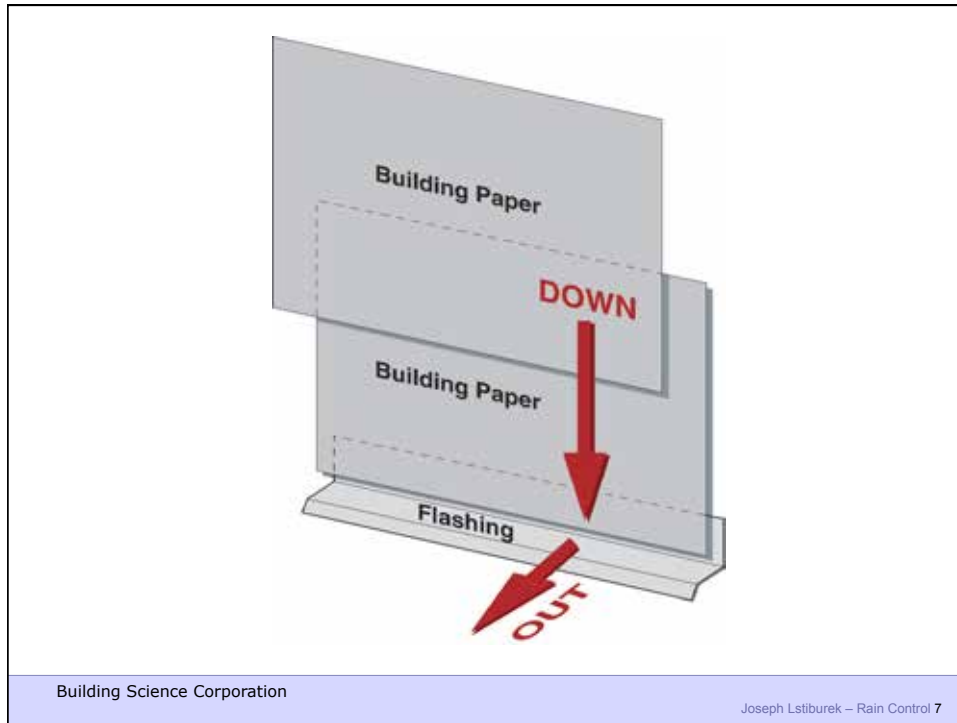

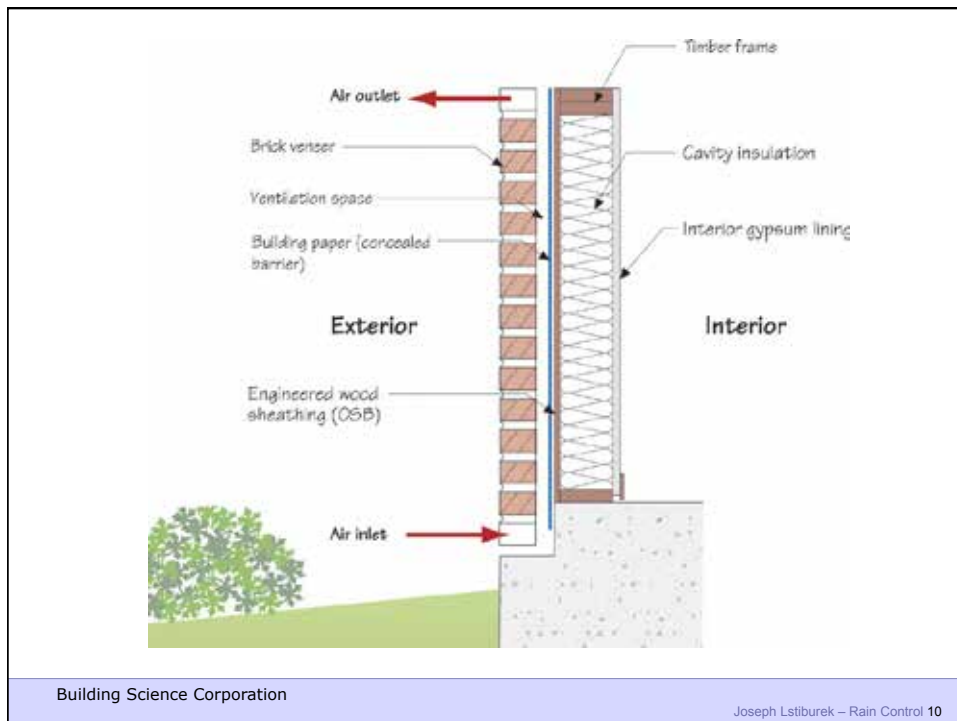
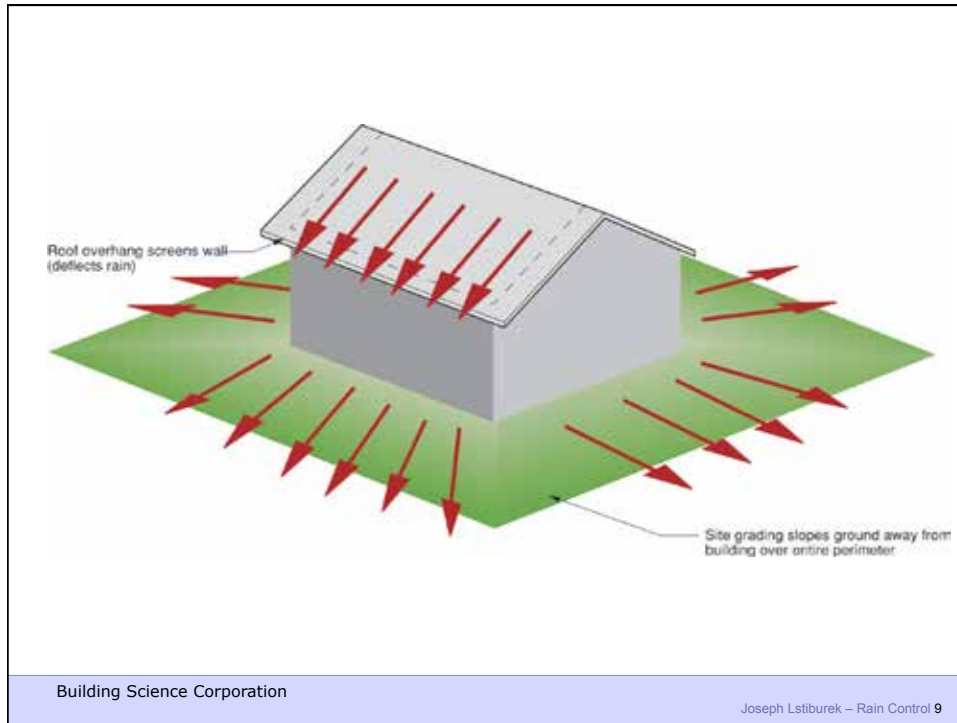



Building Science Corporation

Joseph Lstiburek – Rain Control 11



Building Science Corporation

Joseph Lstiburek – Rain Control 12



Building Science Corporation

Joseph Lstiburek - Foundations 13



Building Science Corporation

Joseph Lstiburek - Rain Control 14



Building Science Corporation

Joseph Lstiburek – Rain Control 15



Building Science Corporation

Joseph Lstiburek – Rain Control 16



Building Science Corporation

Joseph Lstiburek – Rain Control 17



Building Science Corporation

Joseph Lstiburek 18

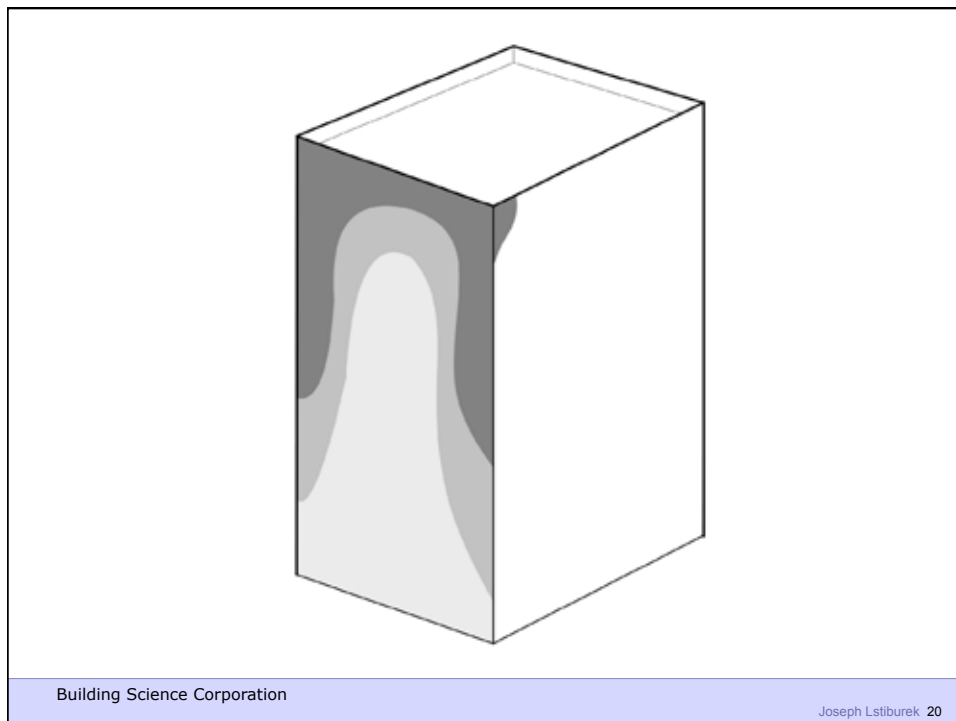
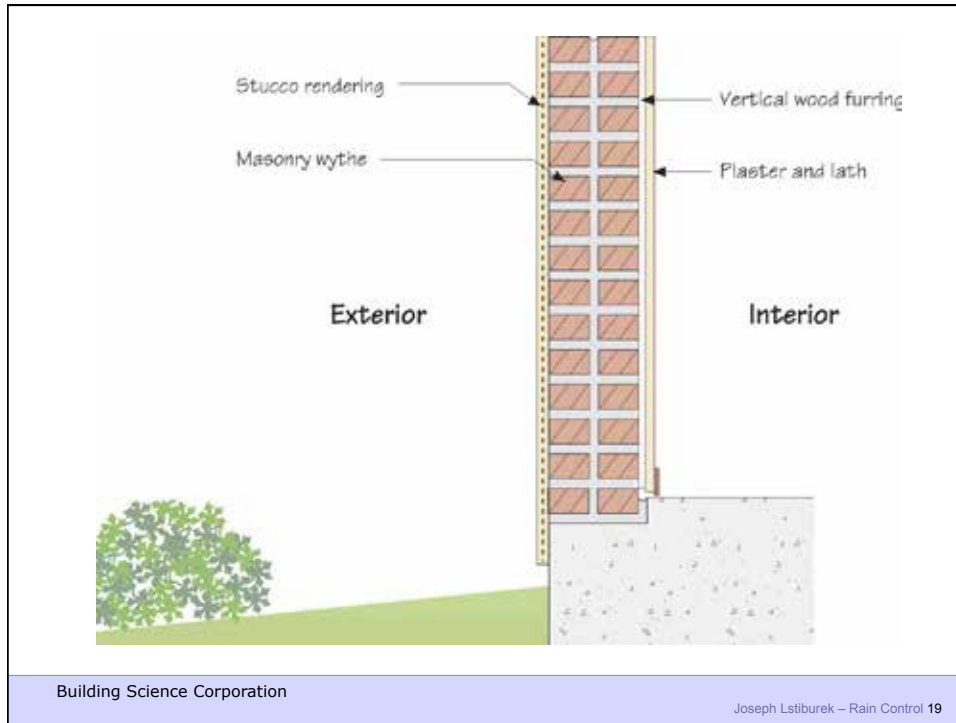



Building Science Corporation

Joseph Lstiburek 21



Building Science Corporation

Joseph Lstiburek 22



Building Science Corporation

Joseph Lstiburek 23



Building Science Corporation

Joseph Lstiburek 24



Building Science Corporation

Joseph Lstiburek 25



Building Science Corporation

Joseph Lstiburek 26

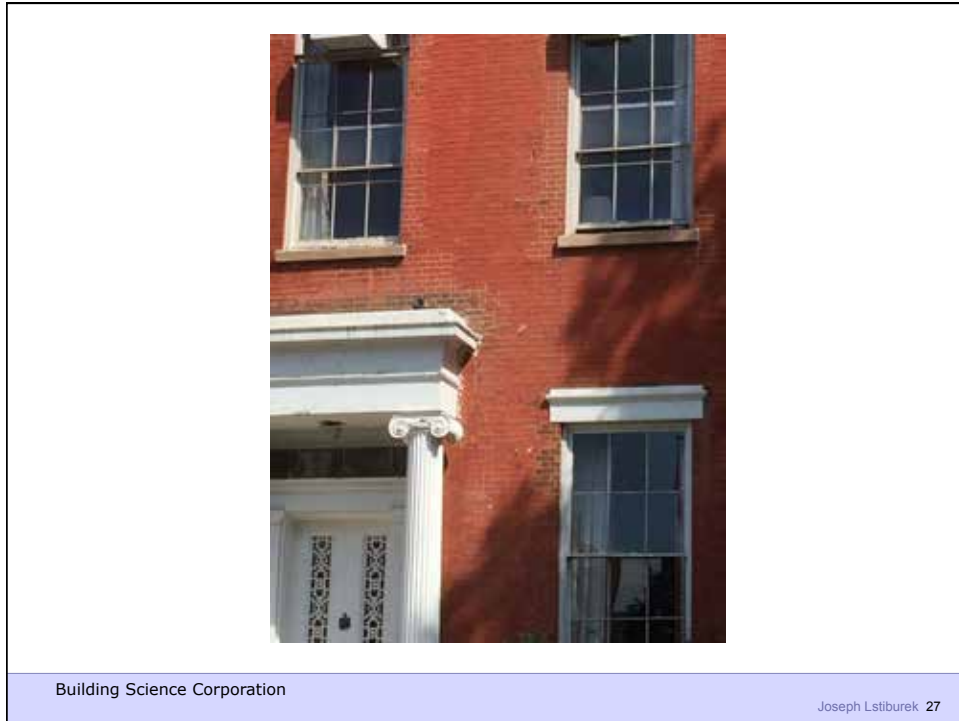

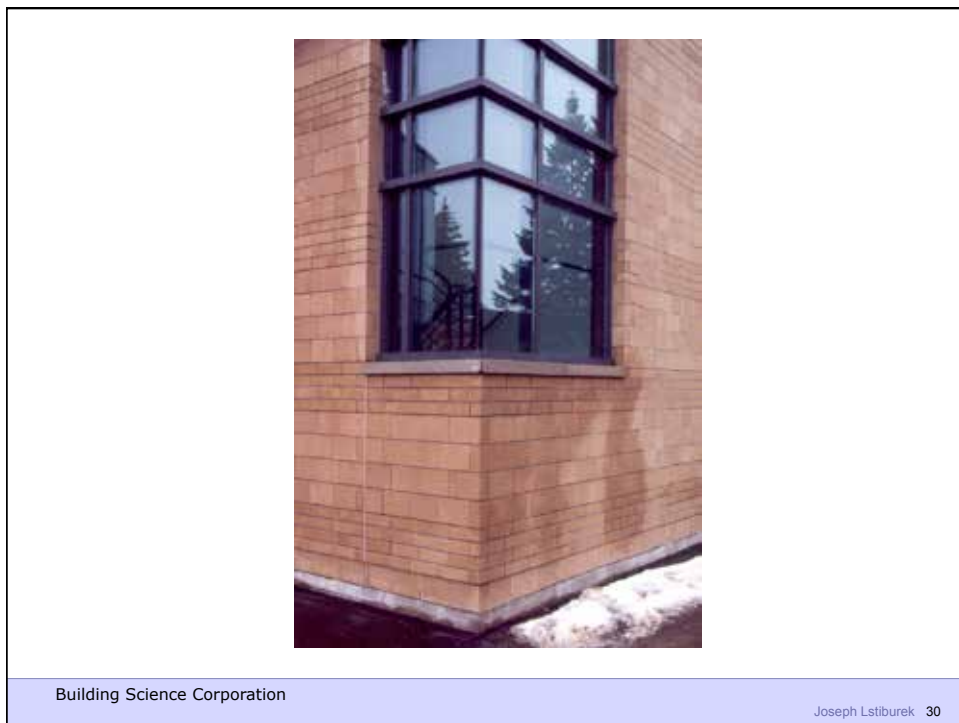



Building Science Corporation

Joseph Lstiburek 31



Building Science Corporation

Joseph Lstiburek 32





Building Science Corporation

Joseph Lstiburek – Rain Control 35

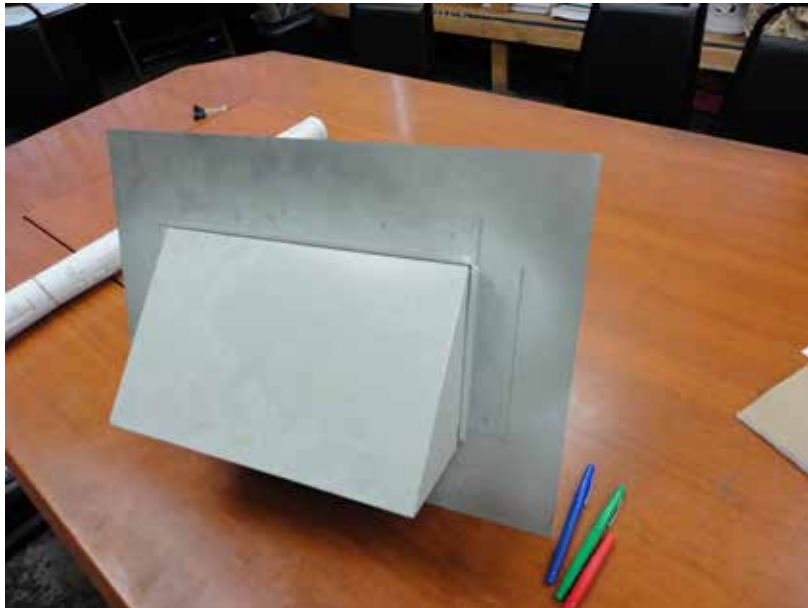

Building Science Corporation

Joseph Lstiburek 36

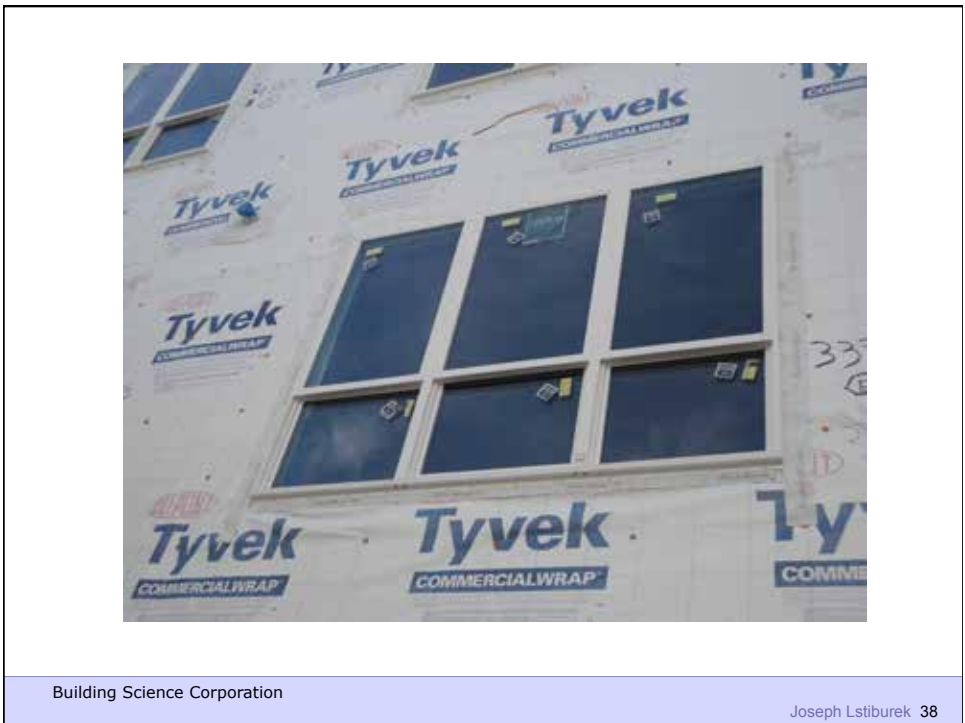
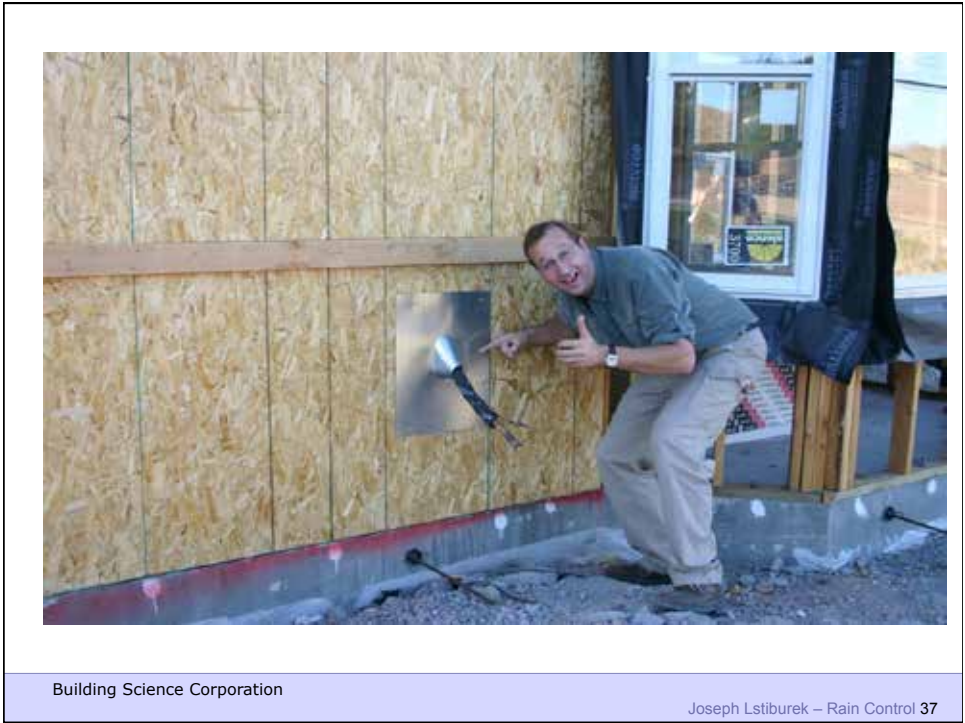



Building Science Corporation

Joseph Lstiburek 39



Building Science Corporation

Joseph Lstiburek 40



Building Science Corporation

Joseph Lstiburek 41



Building Science Corporation

Joseph Lstiburek 42





Building Science Corporation

Joseph Lstiburek 45



Building Science Corporation

Joseph Lstiburek 46



Building Science Corporation

Joseph Lstiburek 47

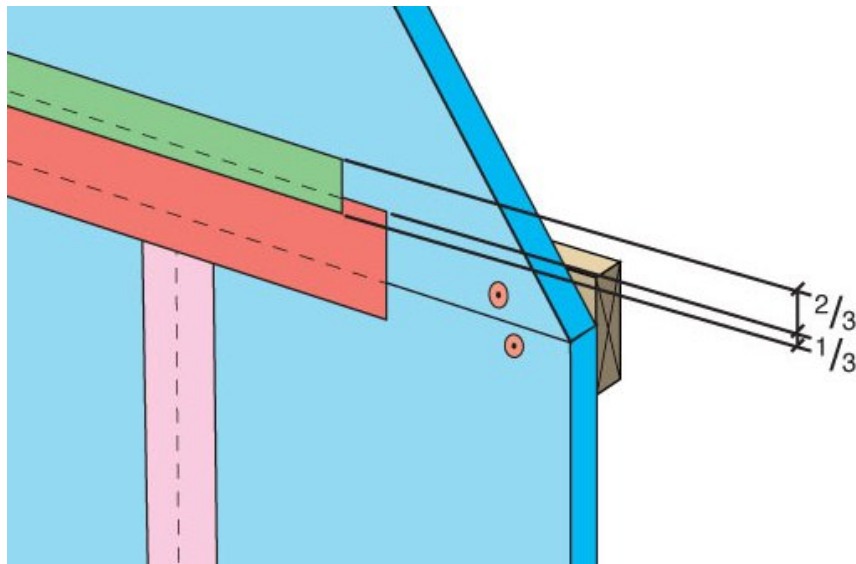

Building Science Corporation

Joseph Lstiburek 48



Joseph Lstiburek, Ph.D., P.Eng, ASHRAE Fellow

Building Science

Roofs

presented by www.buildingscience.com

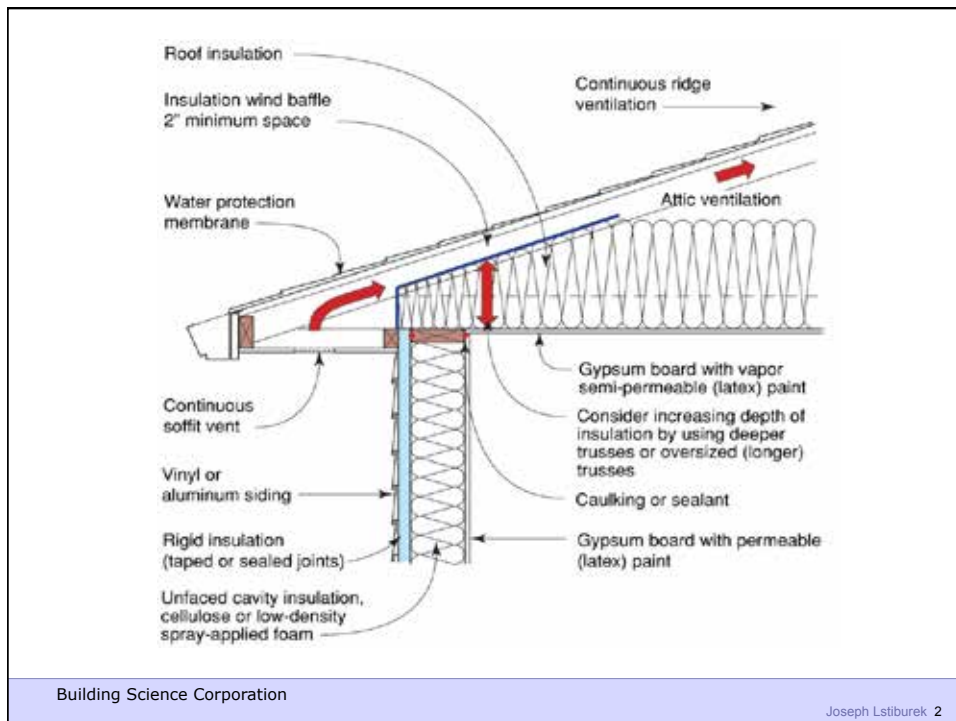



Building Science Corporation

Joseph Lstiburek 3

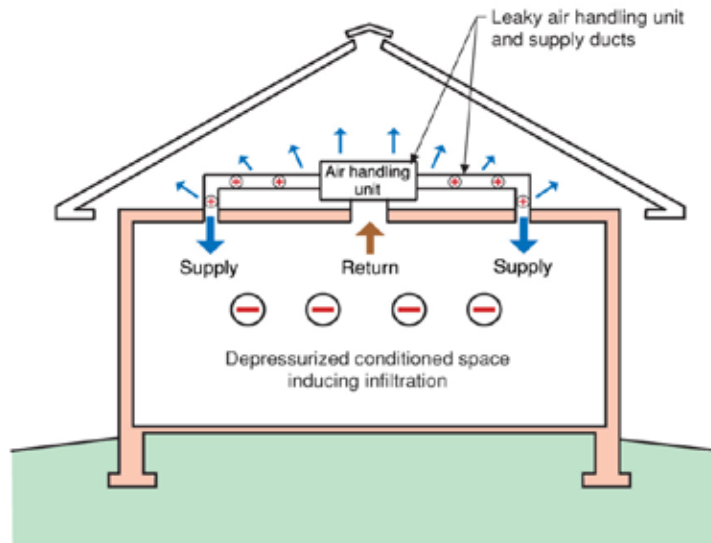

Note: Colored shading depicts the building's thermal barrier and pressure boundary. The thermal barrier and pressure boundary enclose the conditioned space.

Building Science Corporation

Joseph Lstiburek 4



Building Science Corporation

Joseph Lstiburek 5



Building Science Corporation

Joseph Lstiburek 6



Building Science Corporation

Joseph Lstiburek 7



Building Science Corporation

Joseph Lstiburek 8

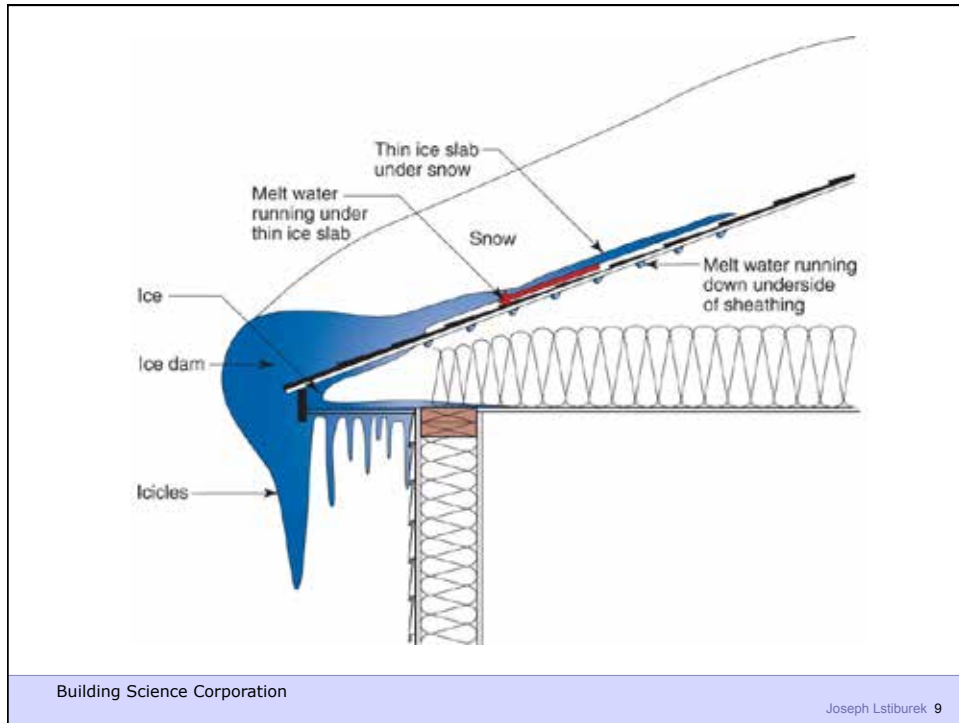



Building Science Corporation

Joseph Lstiburek 11



Building Science Corporation

Joseph Lstiburek 12



Building Science Corporation

Joseph Lstiburek 13



Building Science Corporation

Joseph Lstiburek 14



Building Science Corporation

Joseph Lstiburek 15



Building Science Corporation

Joseph Lstiburek 16

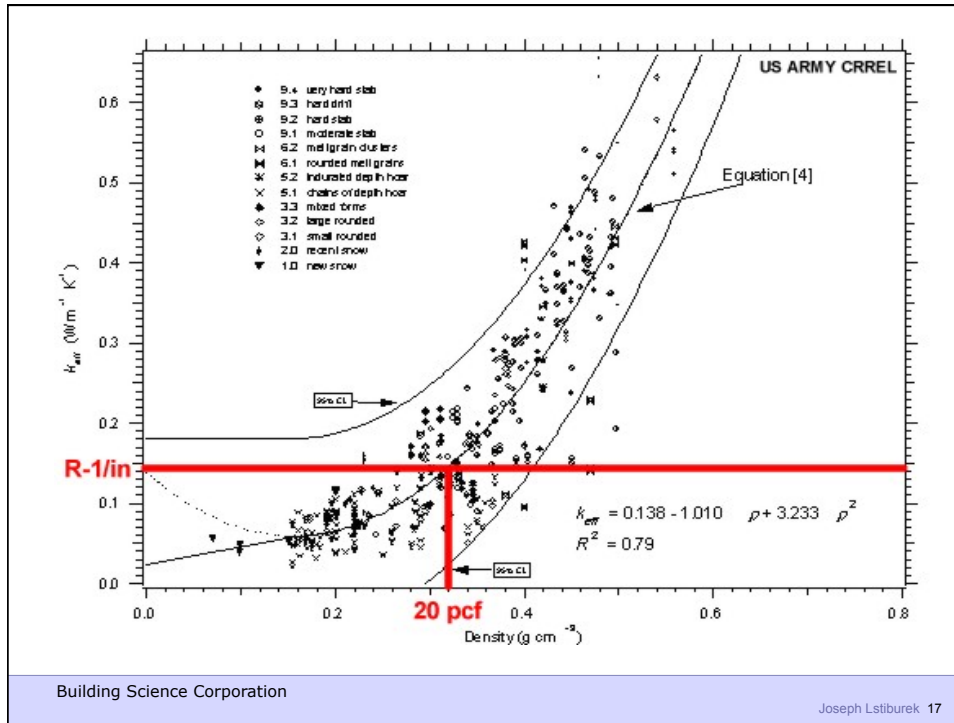

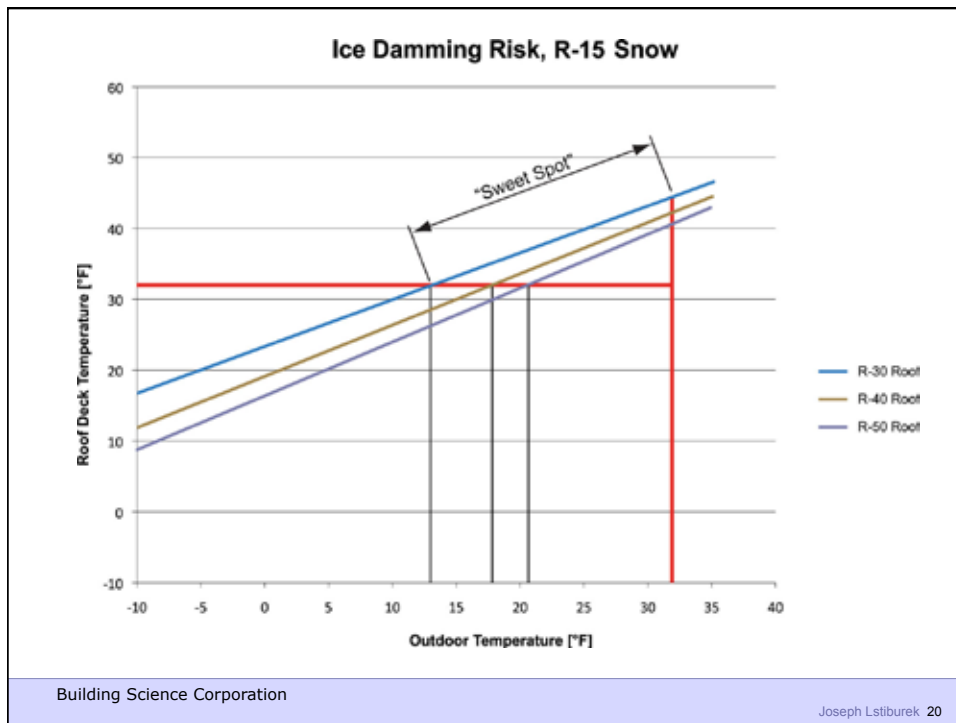
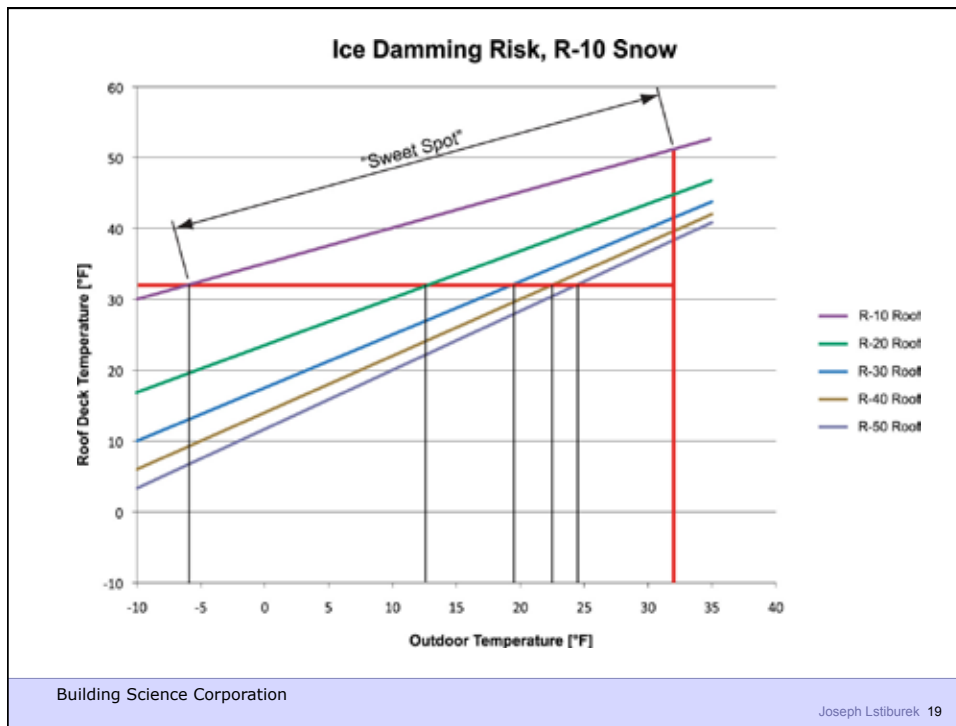

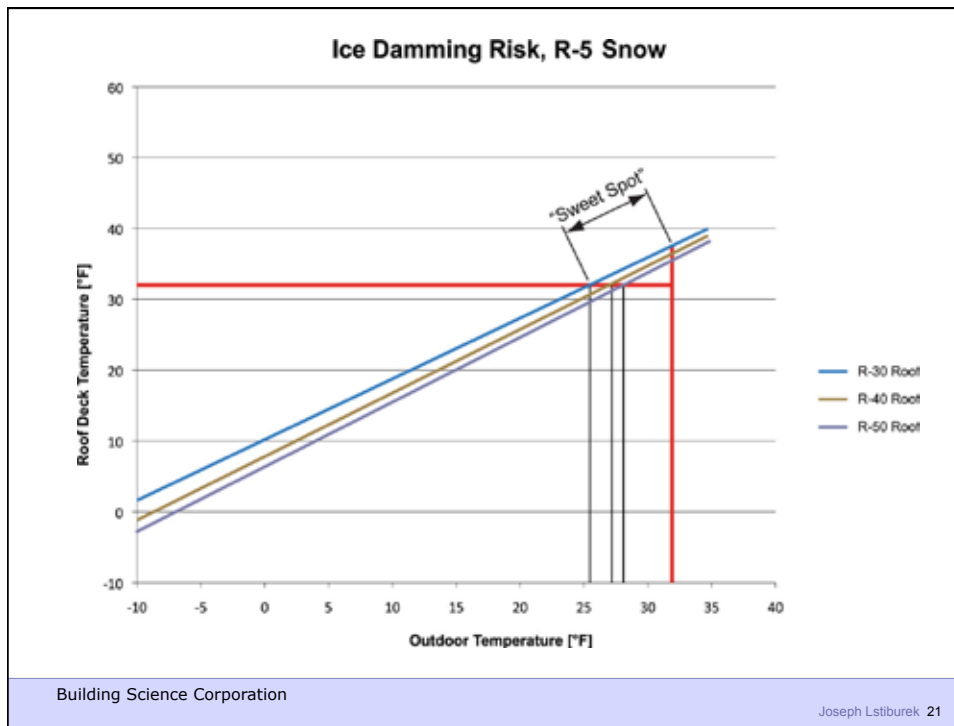

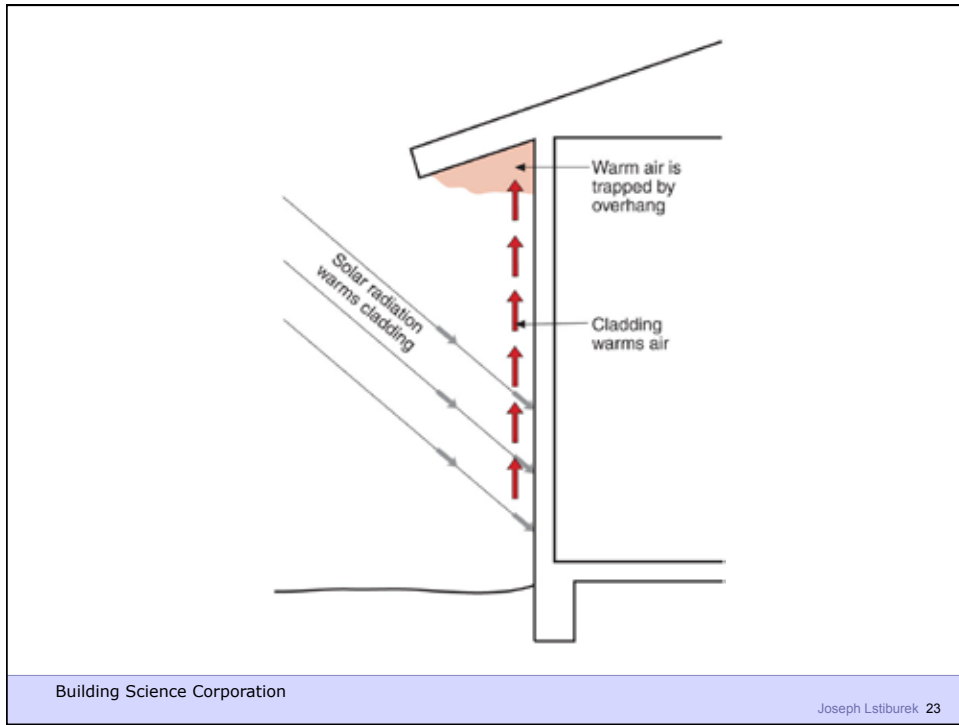



Building Science Corporation

Joseph Lstiburek 25



Building Science Corporation

Joseph Lstiburek 26



Building Science Corporation

Joseph Lstiburek 27

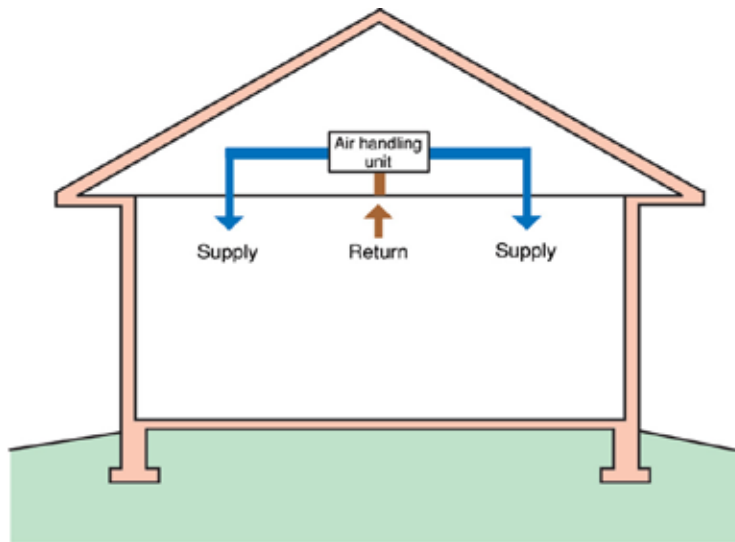

Note: Colored shading depicts the building's thermal barrier and pressure boundary. The thermal barrier and pressure boundary enclose the conditioned space.

Building Science Corporation

Joseph Lstiburek 28

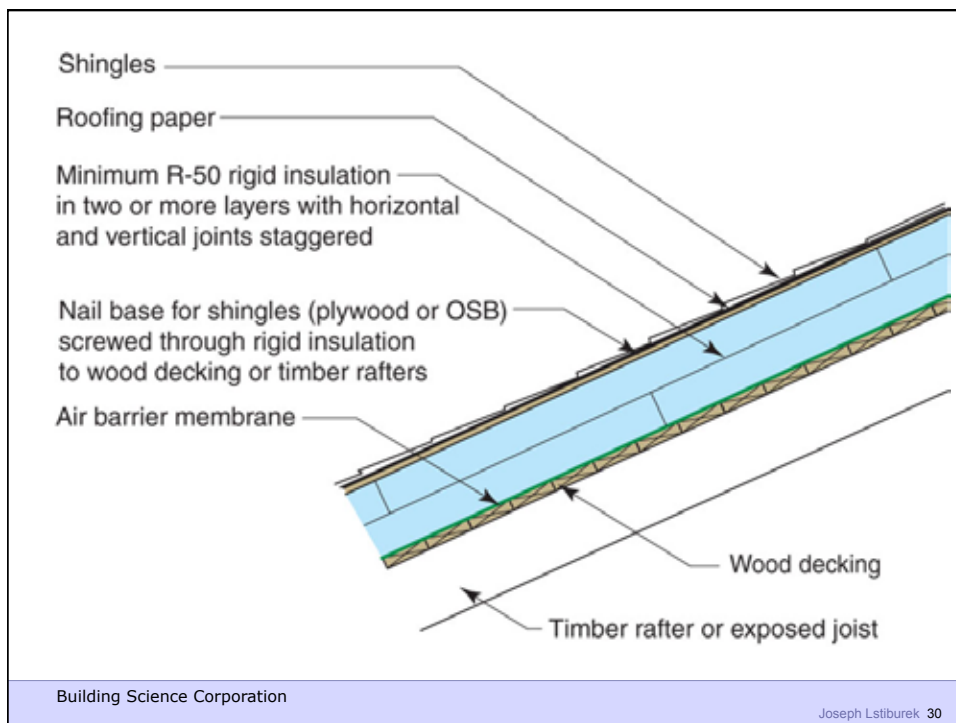
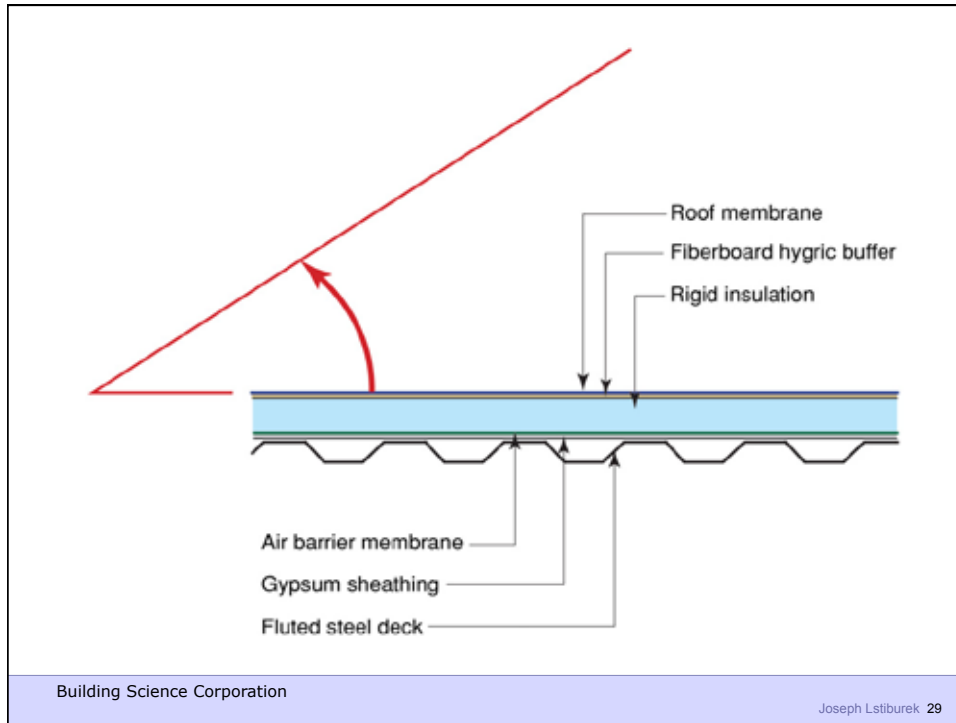

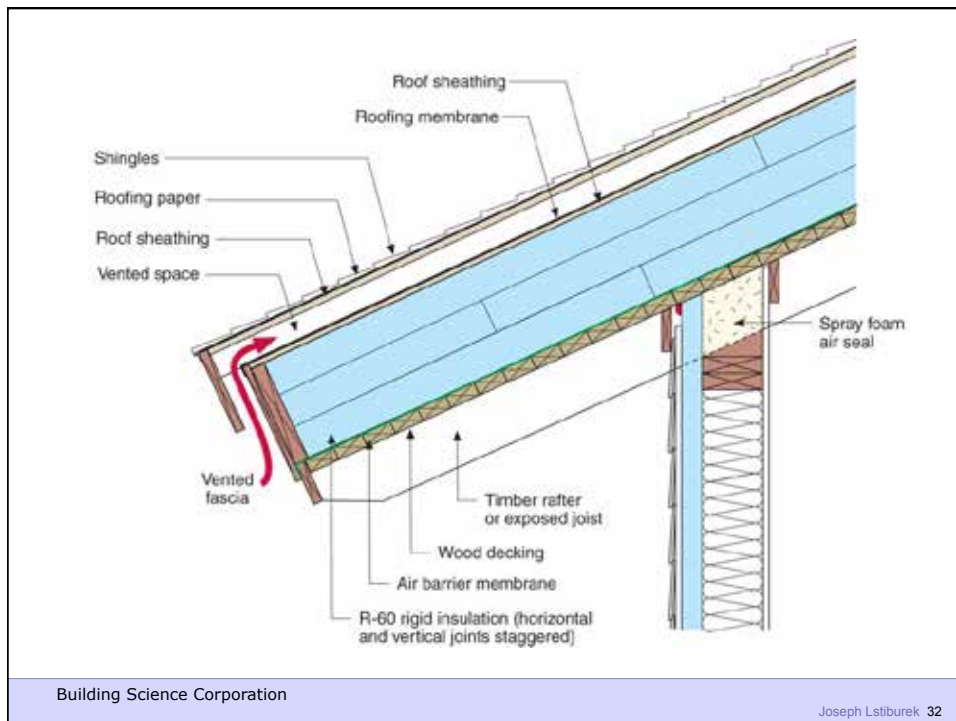
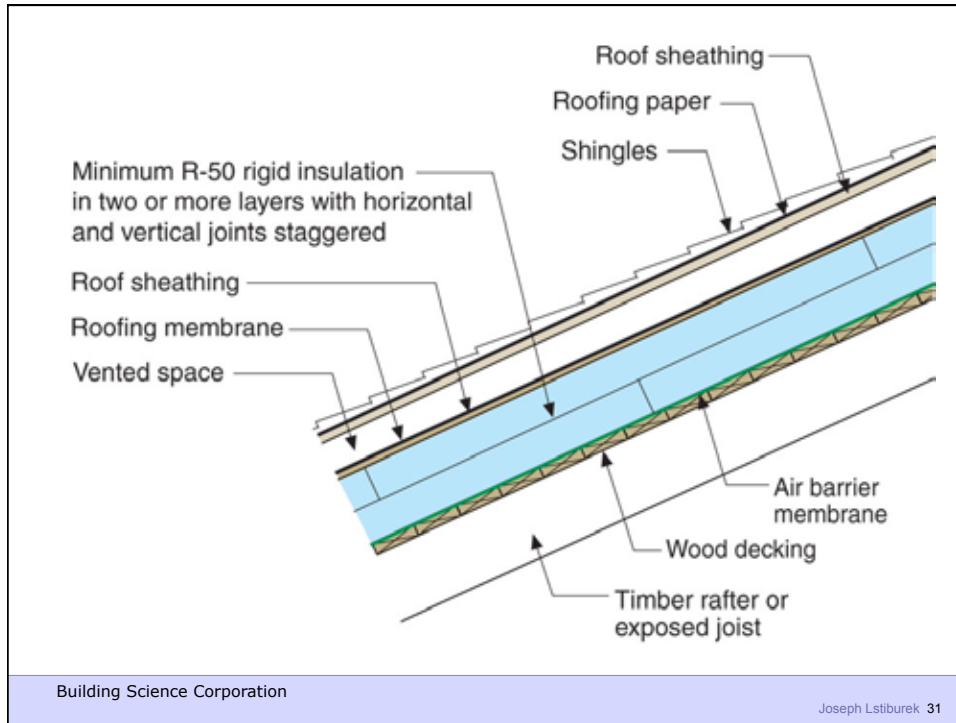

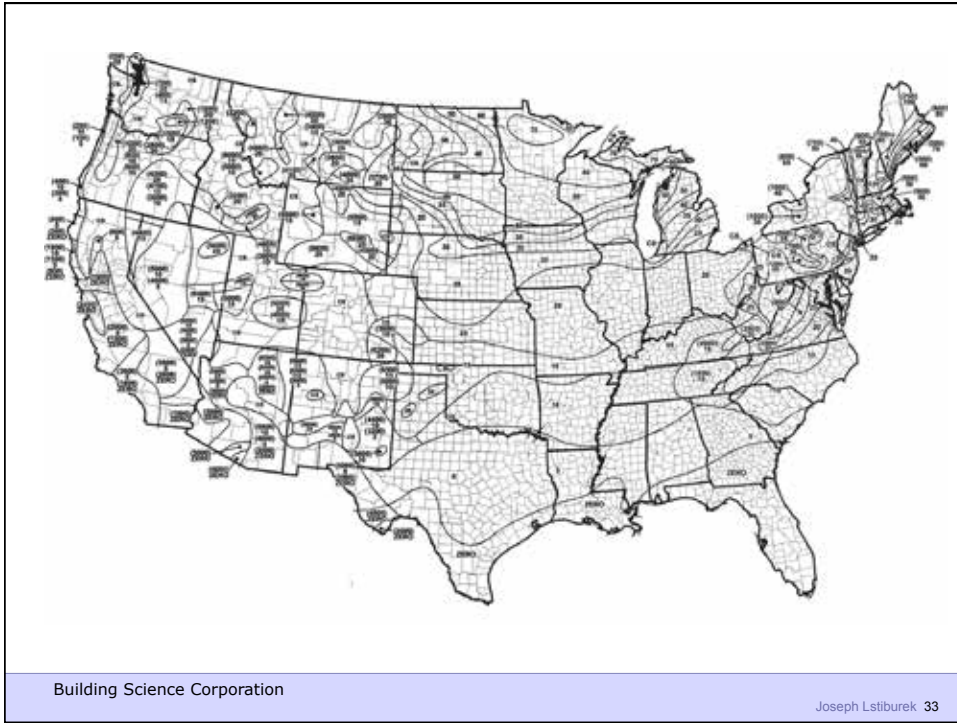



Building Science Corporation

Joseph Lstiburek 35



Building Science Corporation

Joseph Lstiburek 36



Building Science Corporation

Joseph Lstiburek 37



Building Science Corporation

Joseph Lstiburek 38



Building Science Corporation

Joseph Lstiburek 39



Building Science Corporation

Joseph Lstiburek 40





Building Science Corporation

Joseph Lstiburek 43



Building Science Corporation

Joseph Lstiburek 44



Building Science Corporation

Joseph Lstiburek 45



Building Science Corporation

Joseph Lstiburek 46

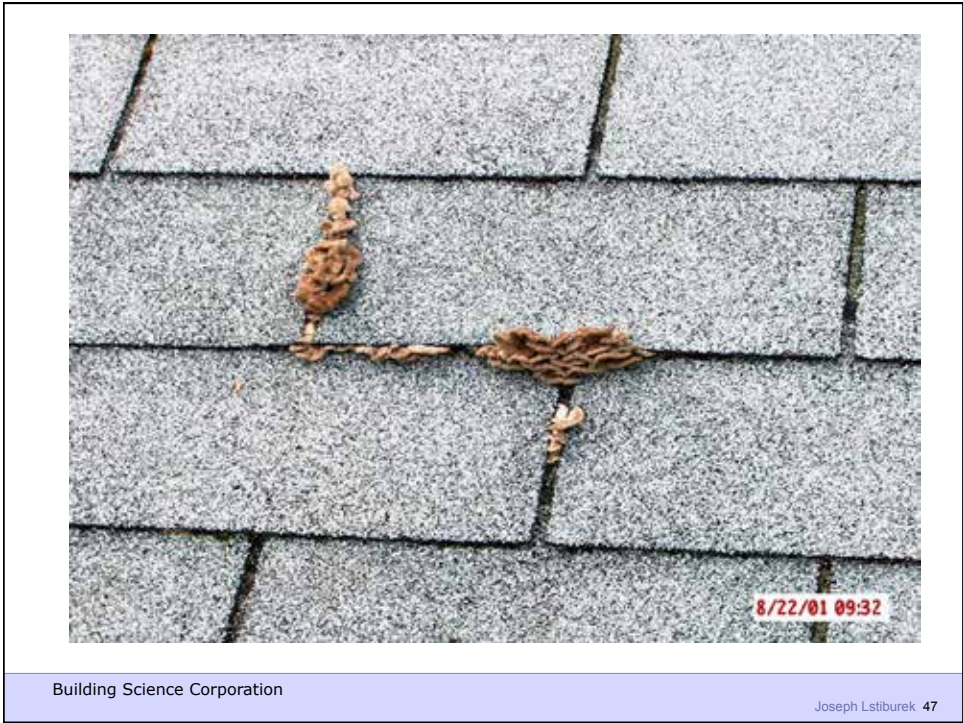



Building Science Corporation

Joseph Lstiburek 49

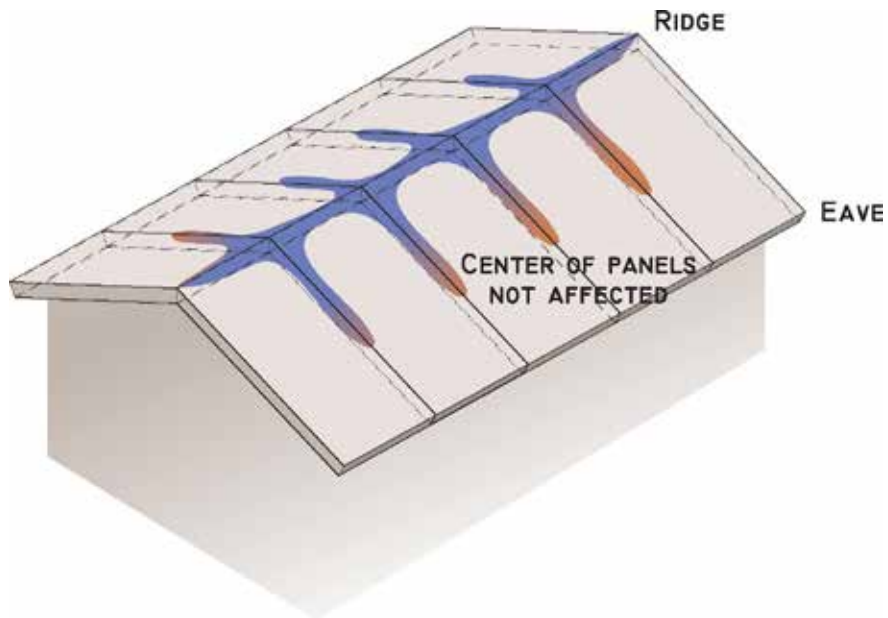

Building Science Corporation

Joseph Lstiburek 50

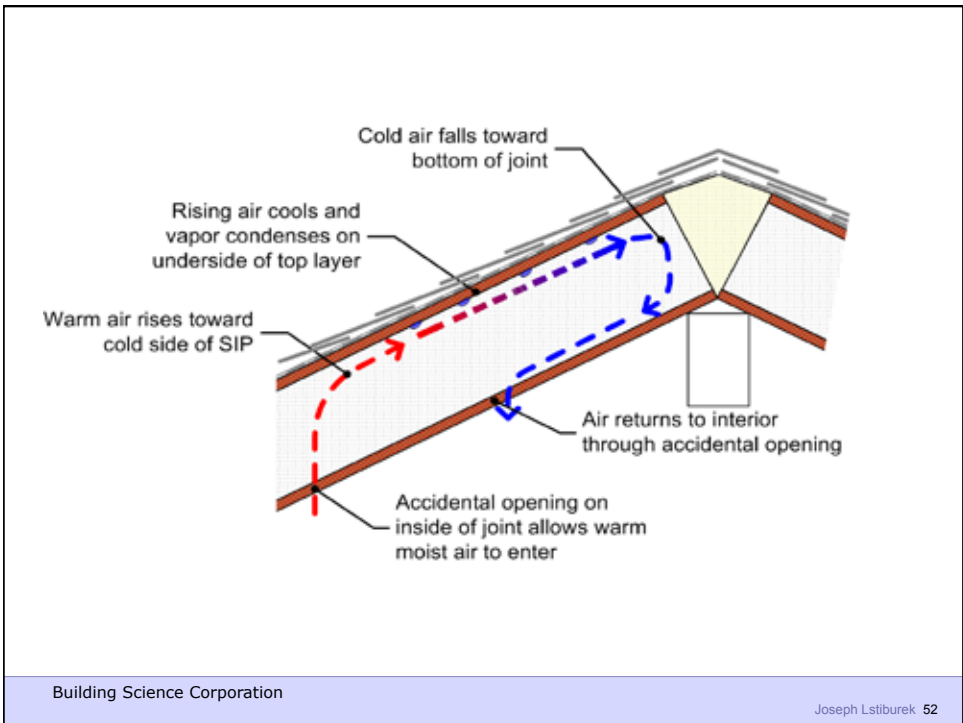

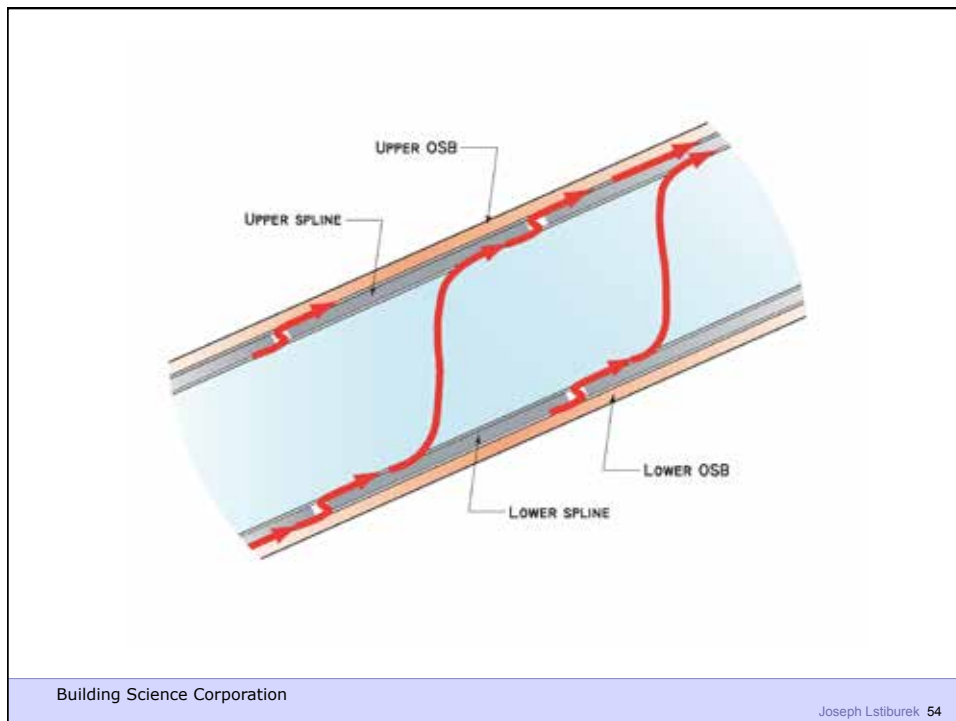
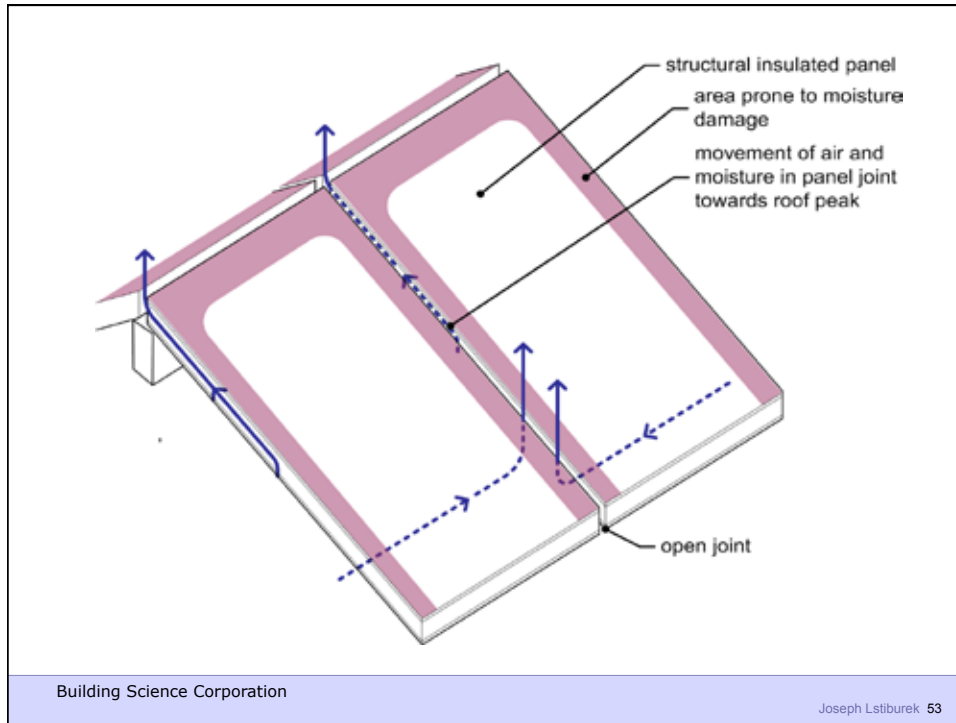



Building Science Corporation

Joseph Lstiburek 55



Building Science Corporation

Joseph Lstiburek 56

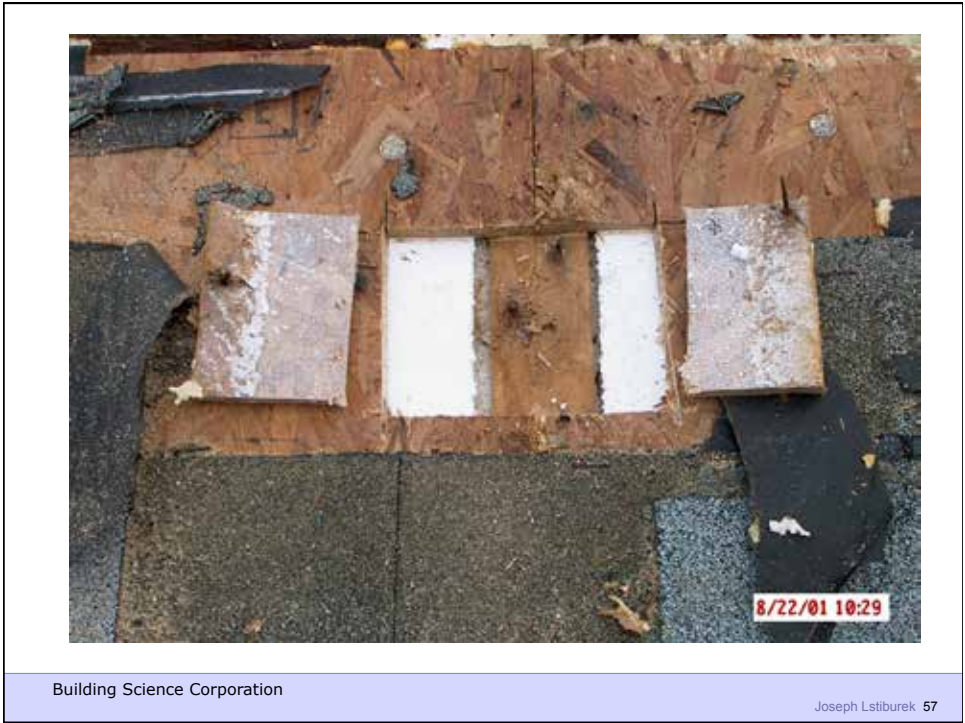



Building Science Corporation

Joseph Lstiburek 59



Building Science Corporation

Joseph Lstiburek 60



Building Science Corporation

Joseph Lstiburek 61



Building Science Corporation

Joseph Lstiburek 62

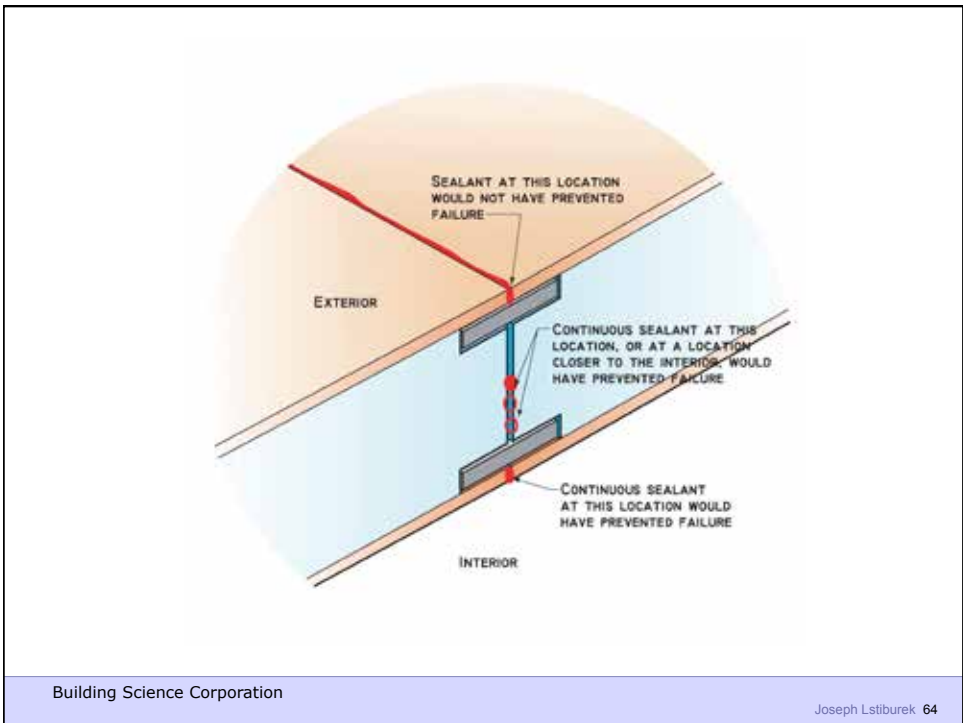

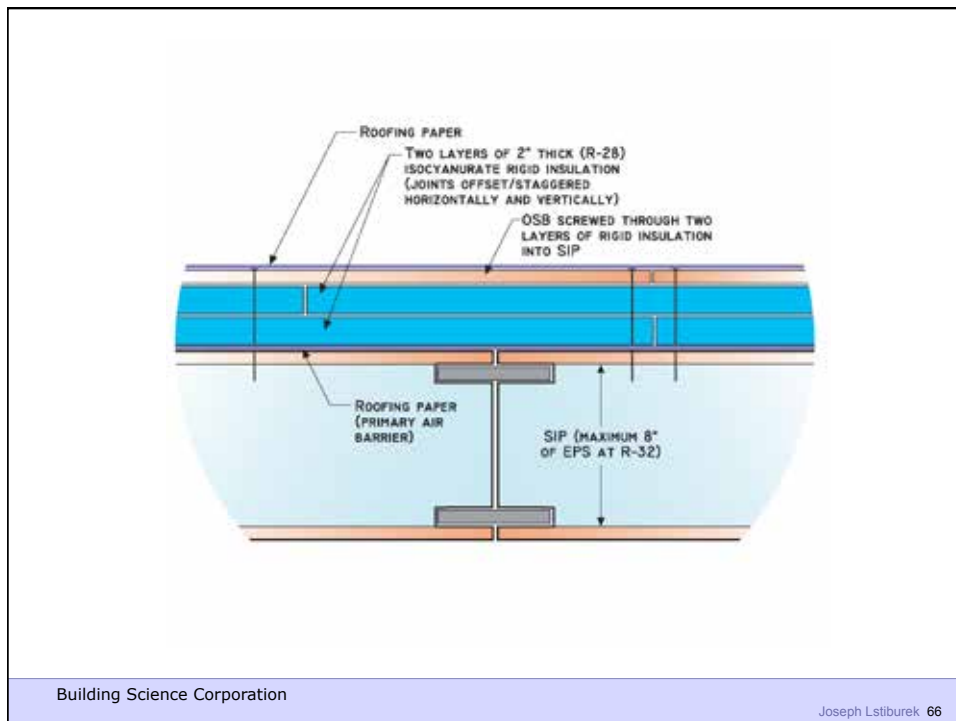
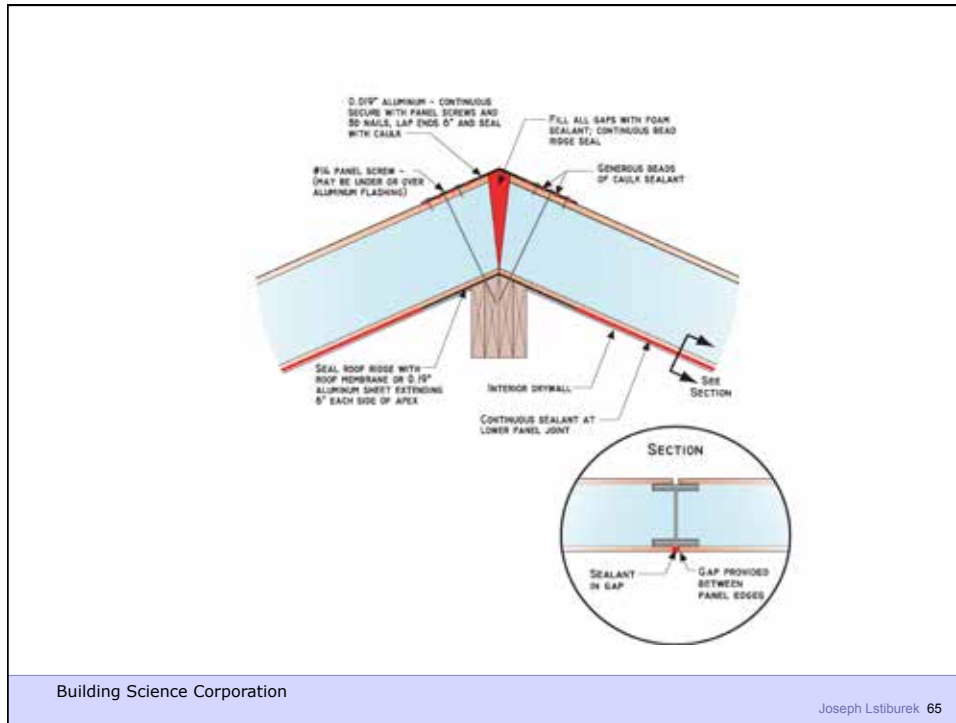

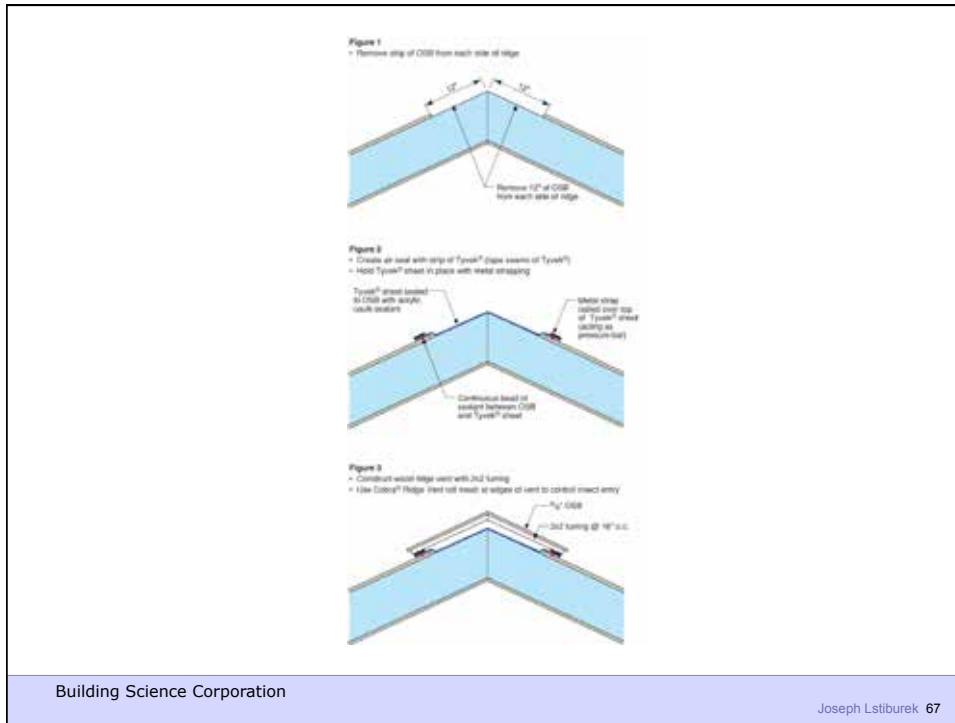

Building Science Corporation

Joseph Lstiburek 67



Building Science Corporation

Joseph Lstiburek 68



Building Science Corporation

Joseph Lstiburek 69



Building Science Corporation

Joseph Lstiburek 70



Building Science Corporation

Joseph Lstiburek 71



Building Science Corporation

Joseph Lstiburek 72



Building Science Corporation

Joseph Lstiburek 73



Building Science Corporation

Joseph Lstiburek 74



Building Science Corporation

Joseph Lstiburek 75



Building Science Corporation

Joseph Lstiburek 76



Building Science Corporation

Joseph Lstiburek 77



Building Science Corporation

Joseph Lstiburek 78



Building Science Corporation

Joseph Lstiburek 79



Building Science Corporation

Joseph Lstiburek 80



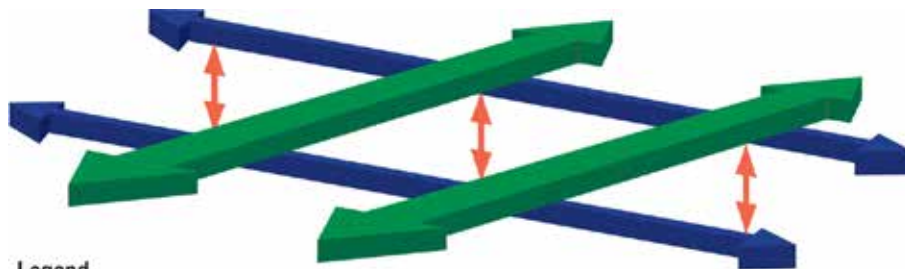

Building Science Corporation

Joseph Lstiburek 81



Legend

-  Upper level air flows
-  Lower level air flows
-  Air flow at panel joints

Building Science Corporation

Joseph Lstiburek 82

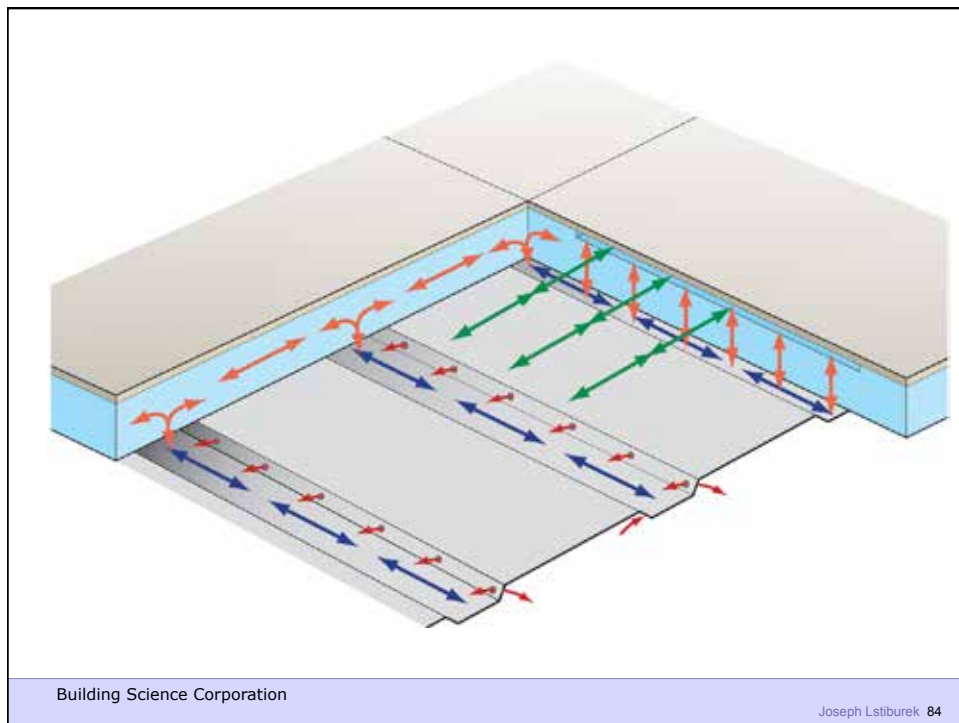
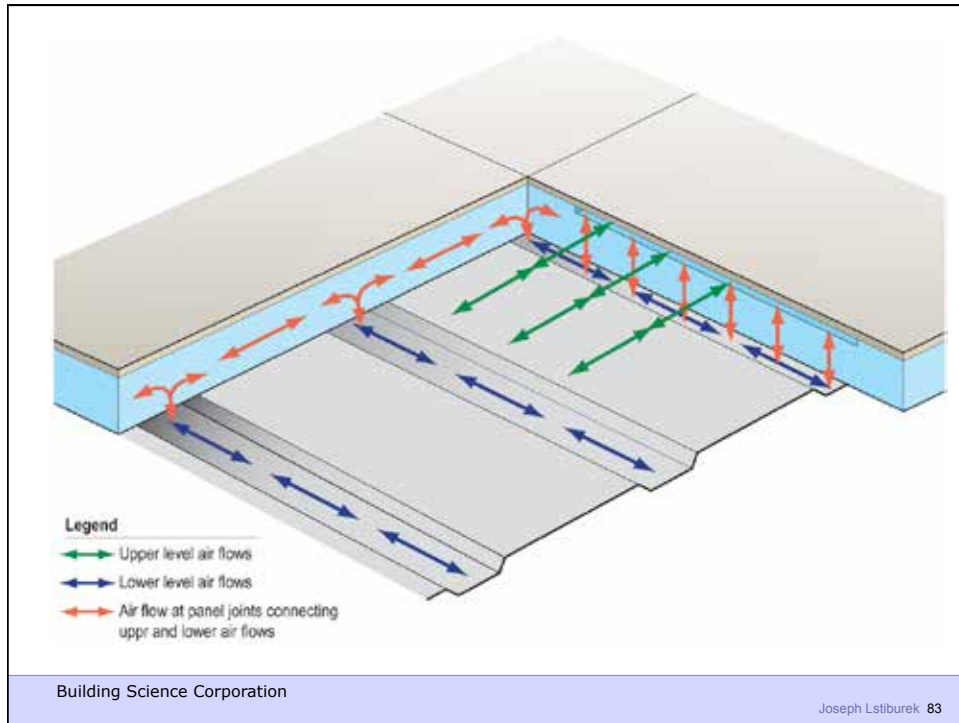



Building Science Corporation

Joseph Lstiburek 85

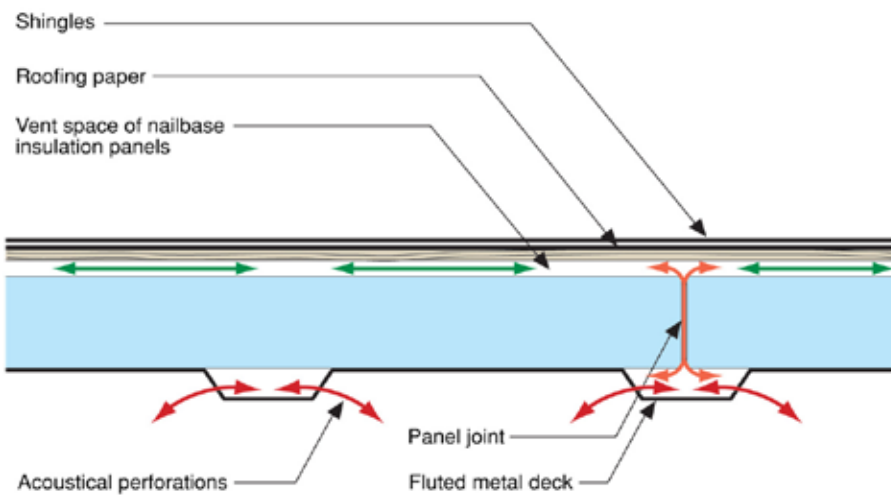

Building Science Corporation

Joseph Lstiburek 86

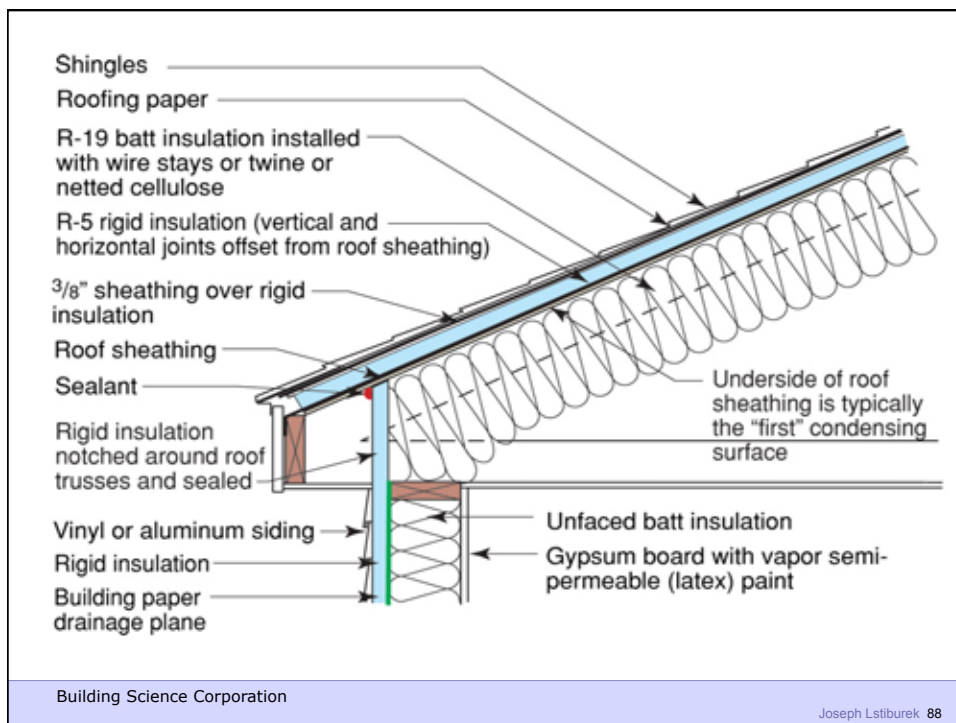
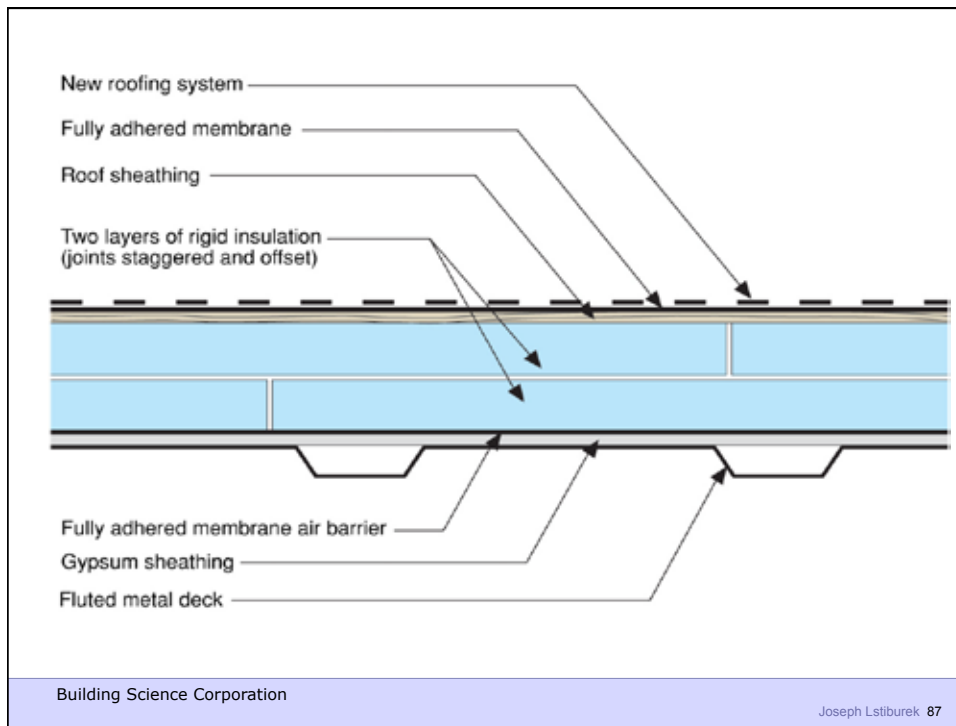

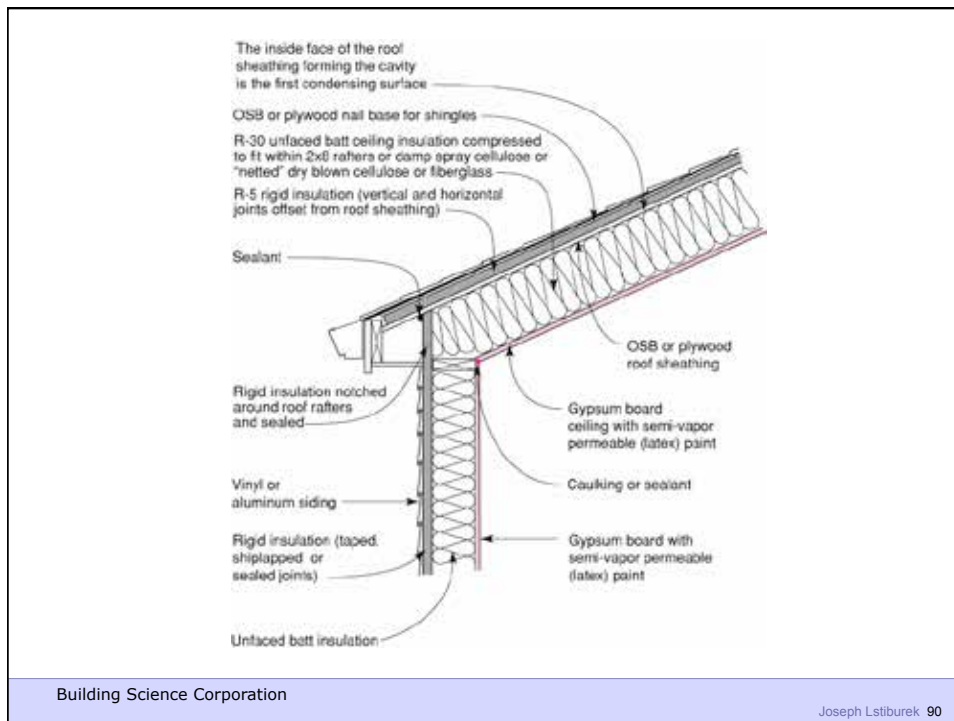
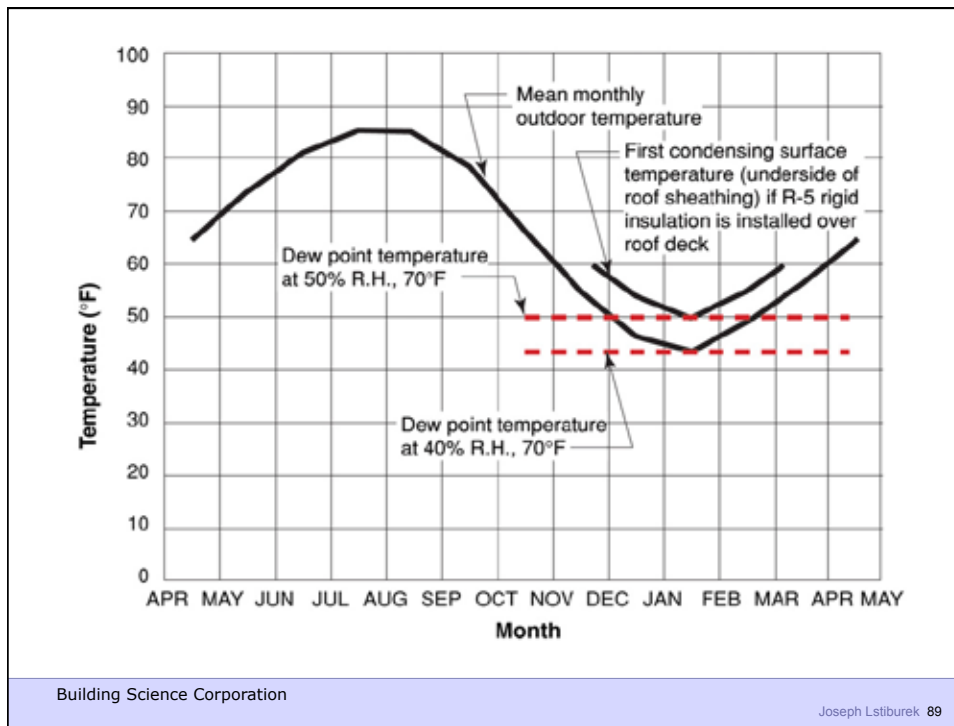

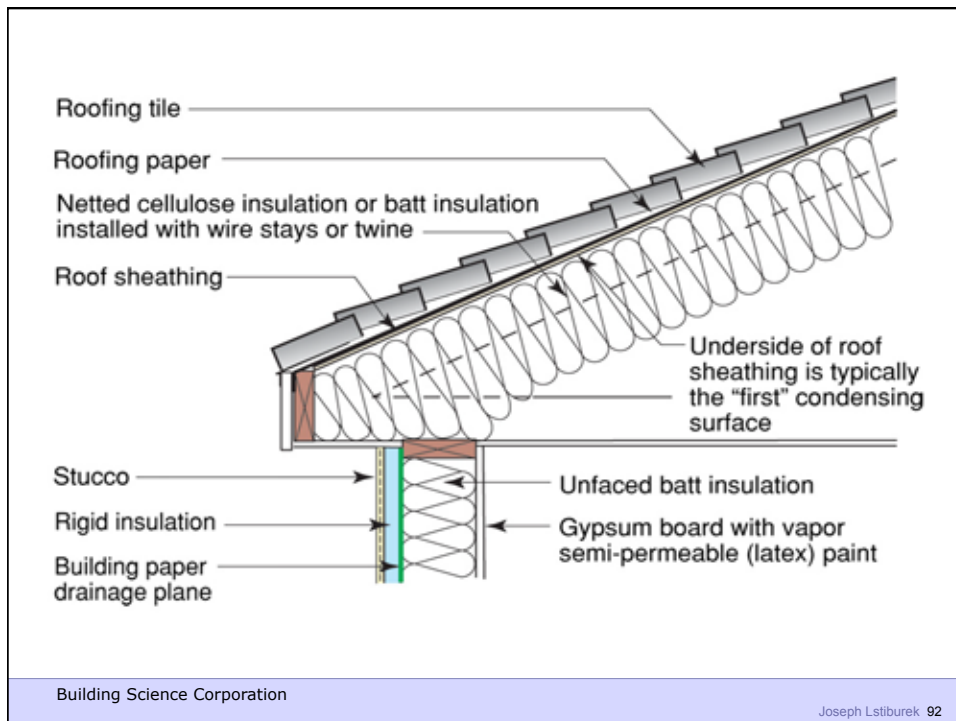
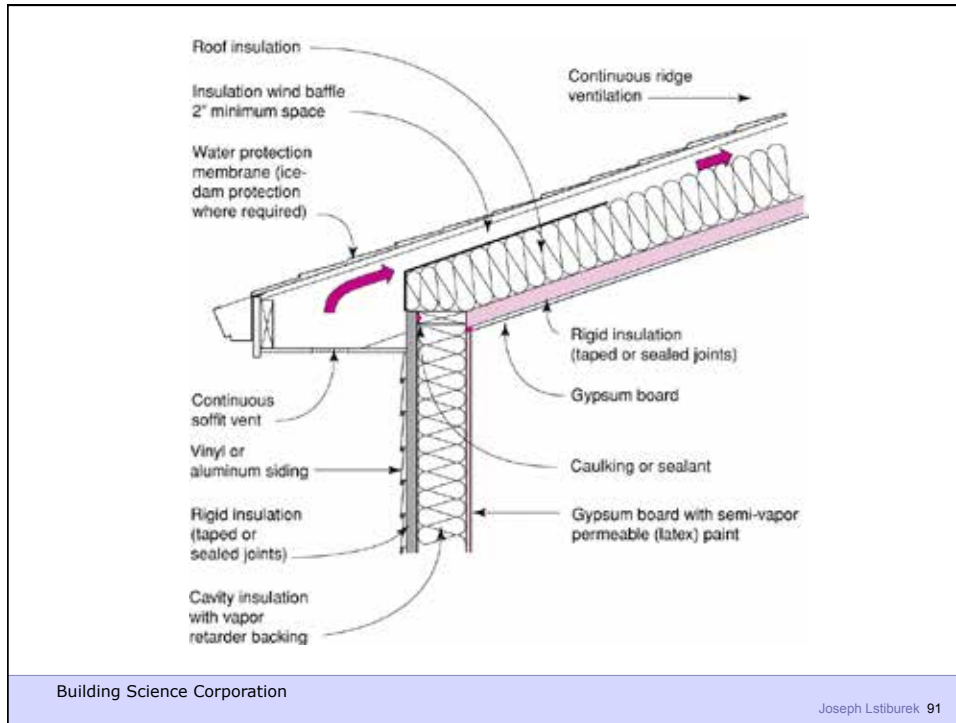

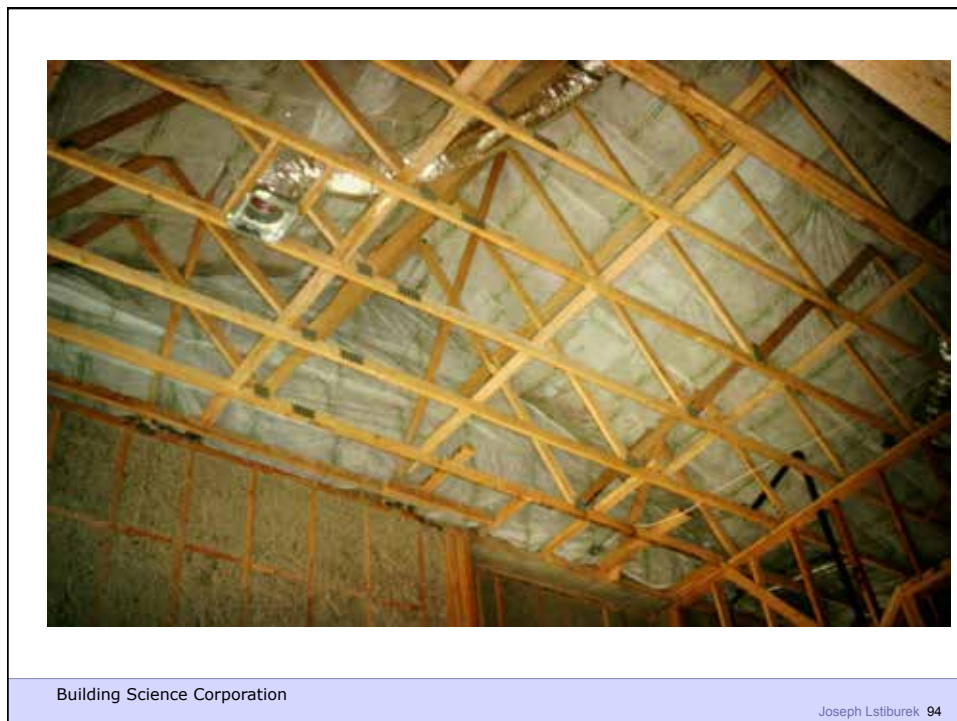



Building Science Corporation

Joseph Lstiburek 95

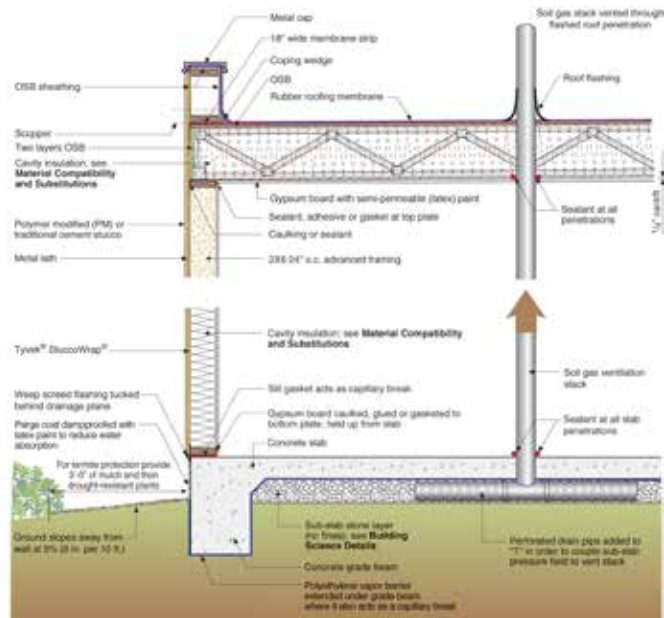

Building Science Corporation

Joseph Lstiburek 96

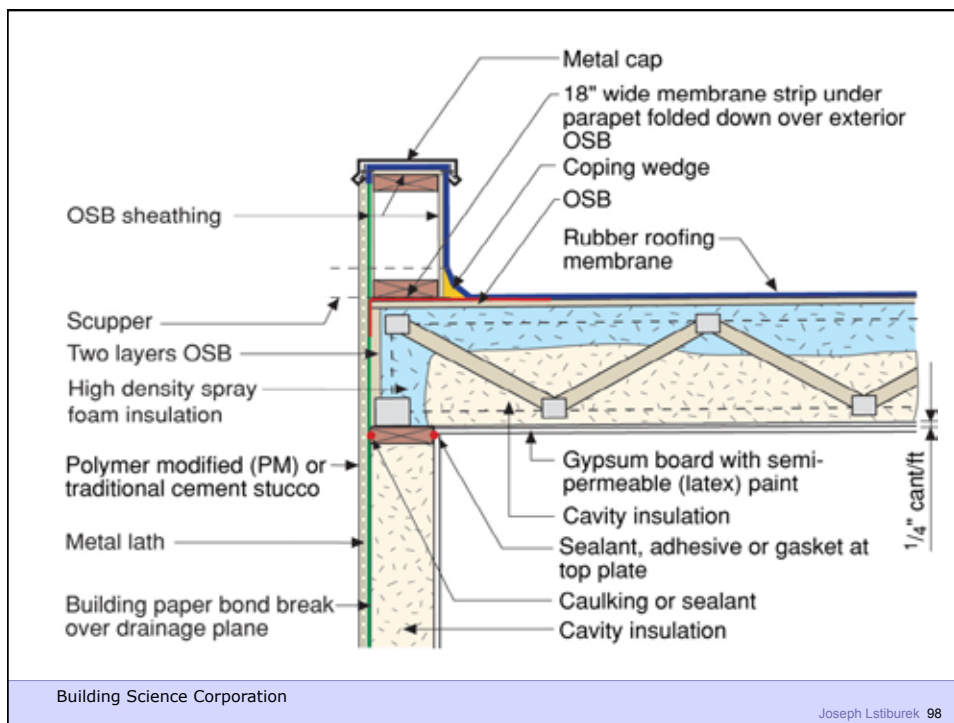
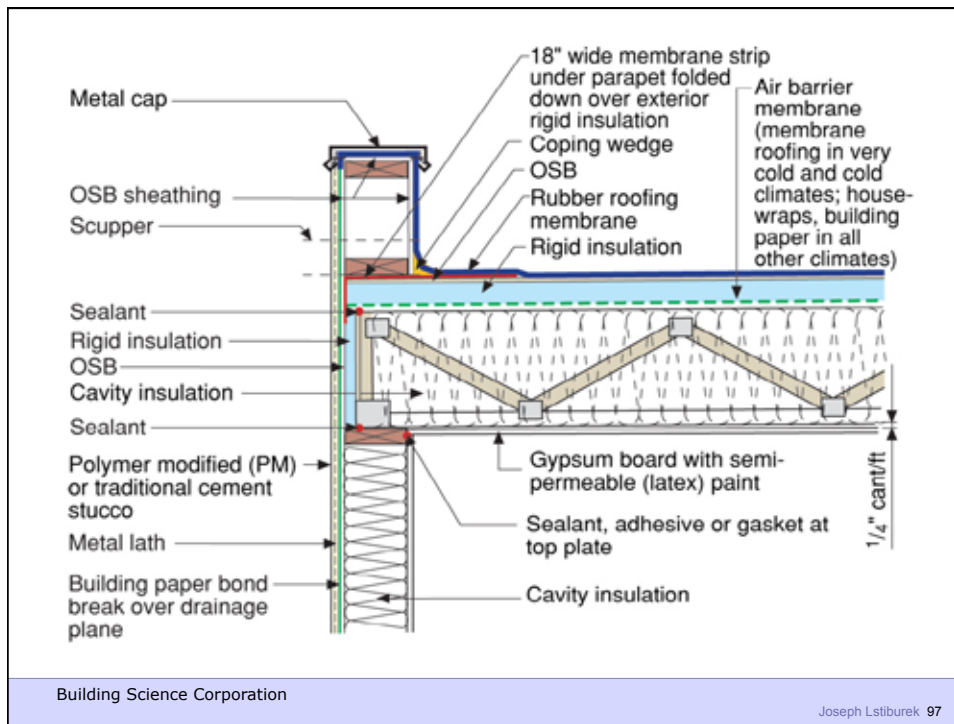

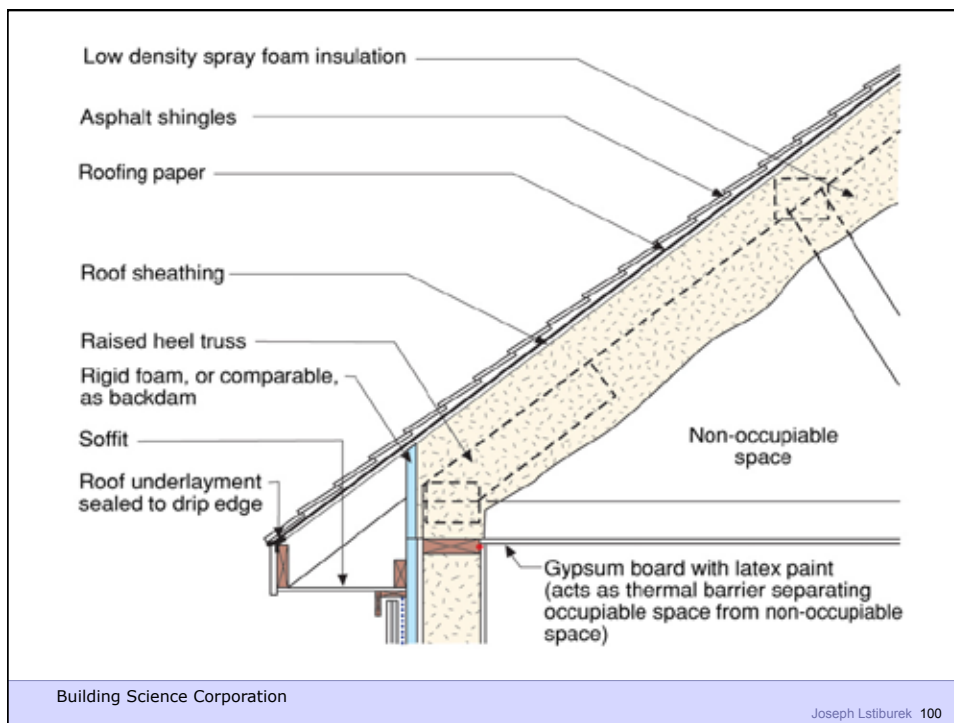
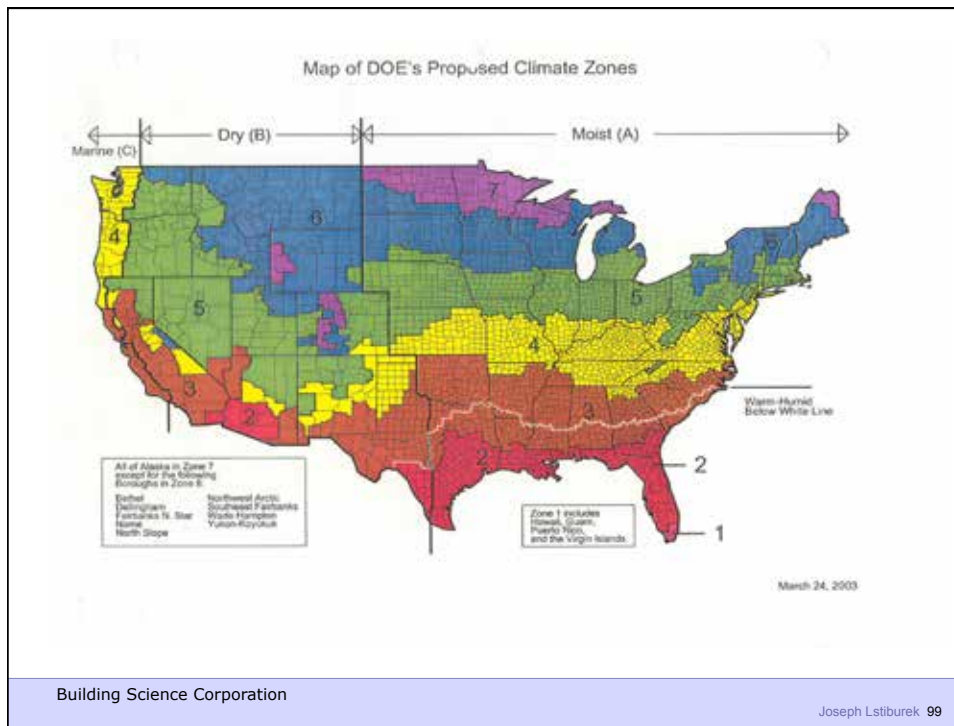



Building Science Corporation

Joseph Lstiburek 101



Building Science Corporation

Joseph Lstiburek 102



Building Science Corporation

Joseph Lstiburek 103



Building Science Corporation

Joseph Lstiburek 104



Building Science Corporation

Joseph Lstiburek 105



Building Science Corporation

Joseph Lstiburek 106



Building Science Corporation

Joseph Lstiburek 107



Building Science Corporation

Joseph Lstiburek 108

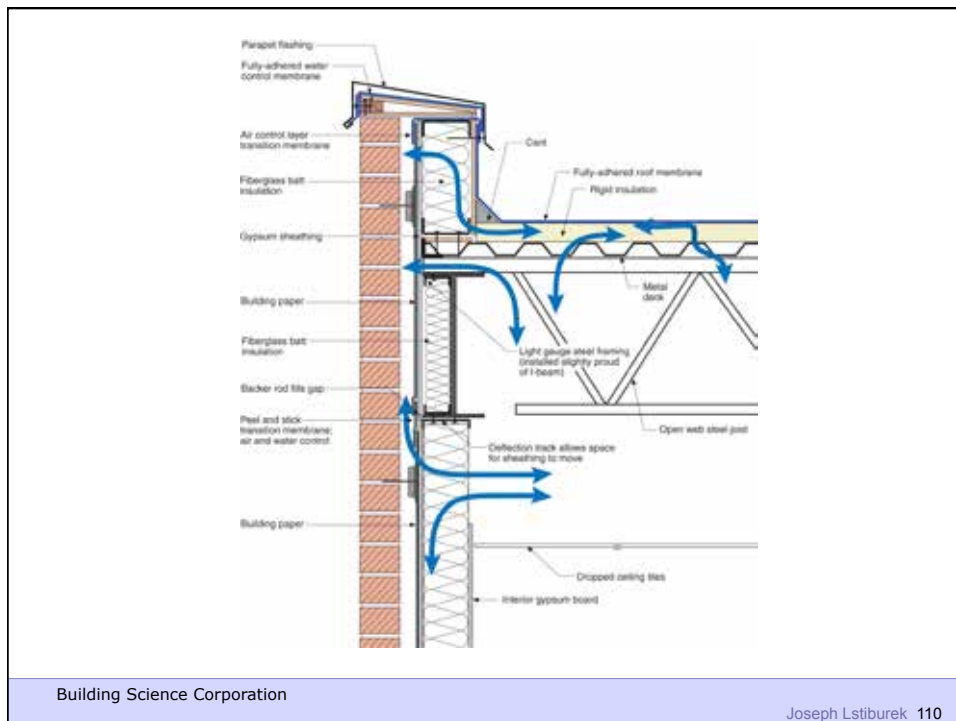
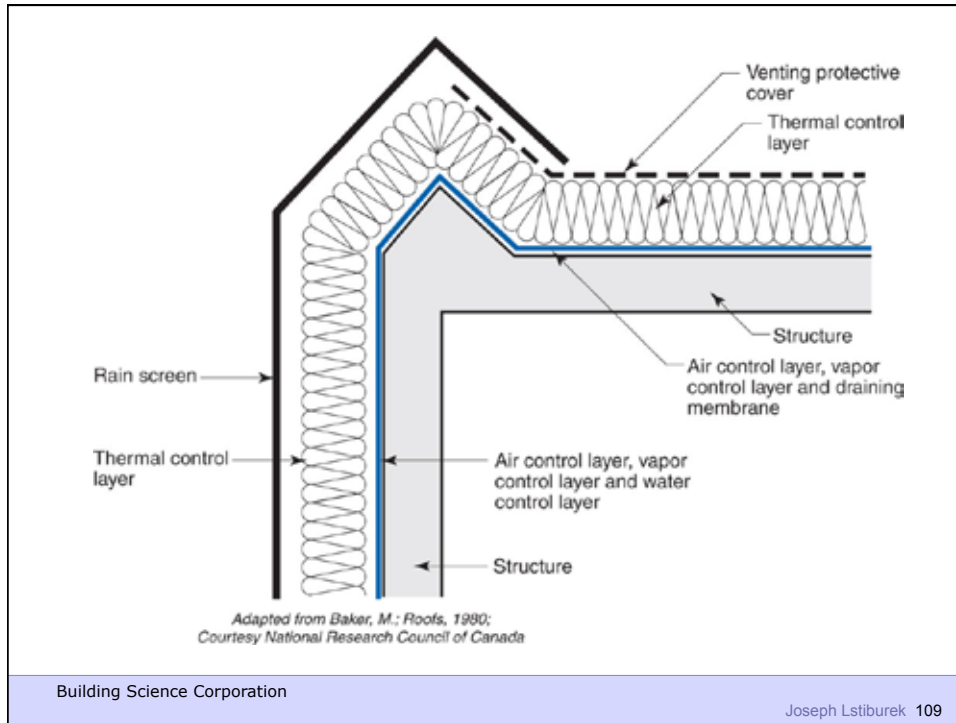

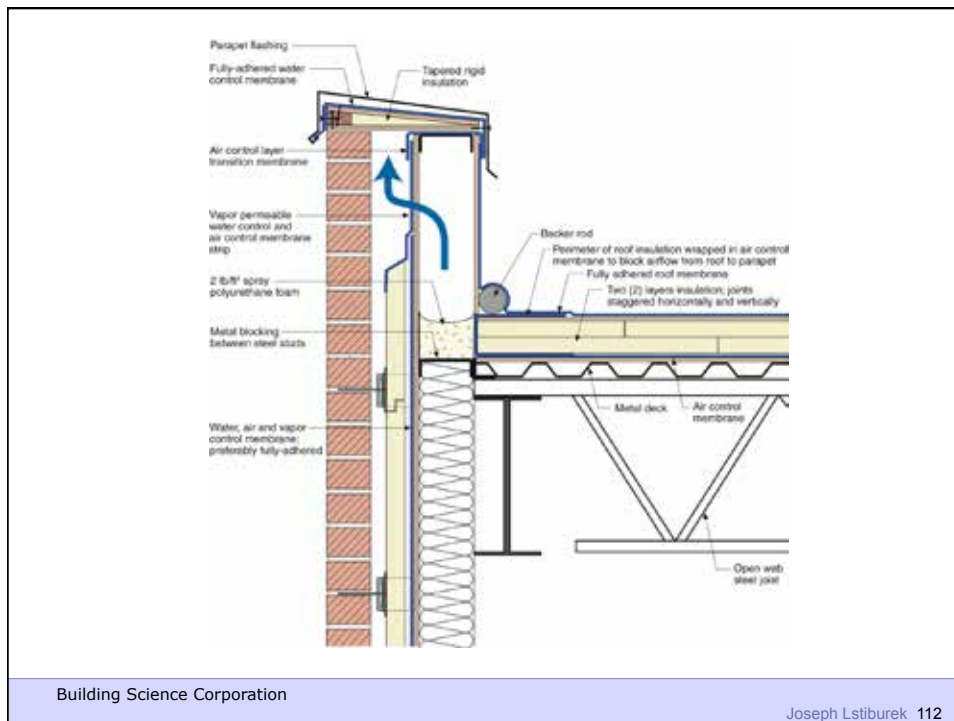
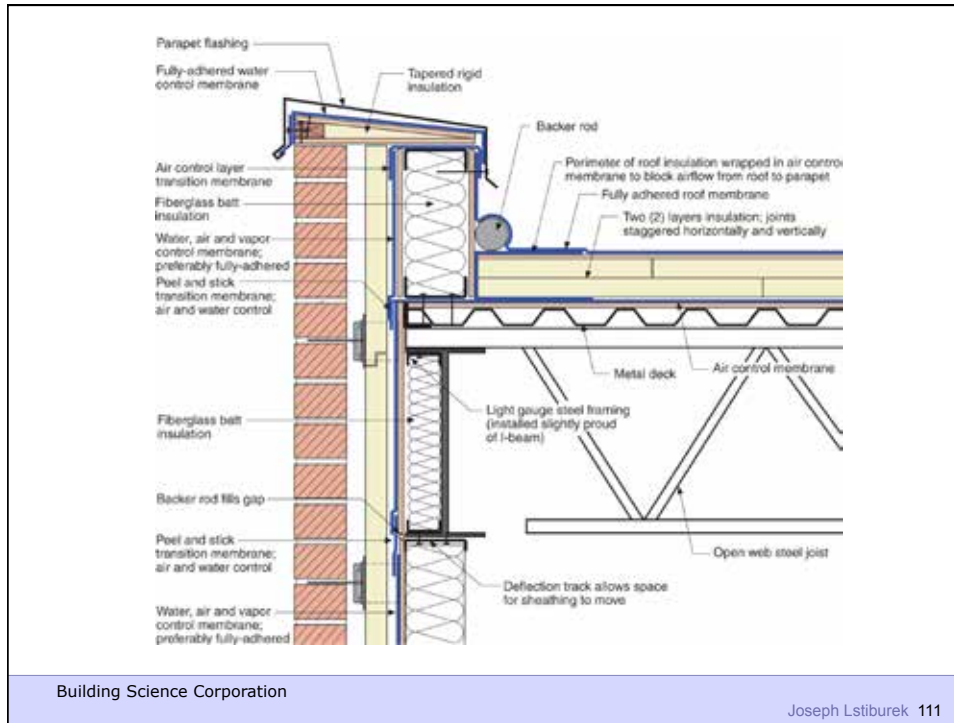

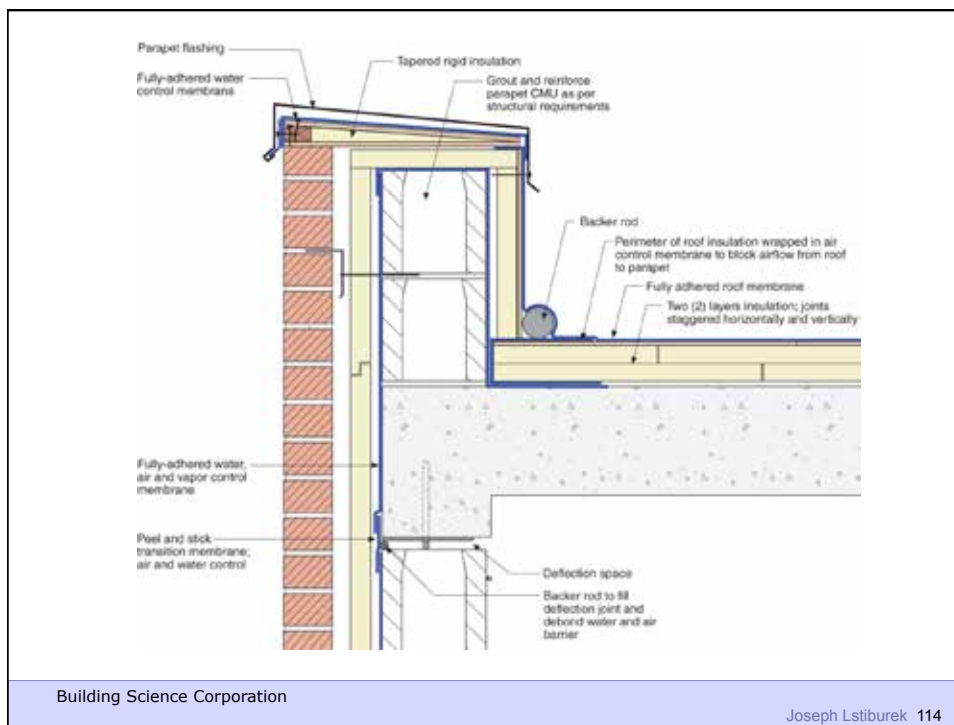
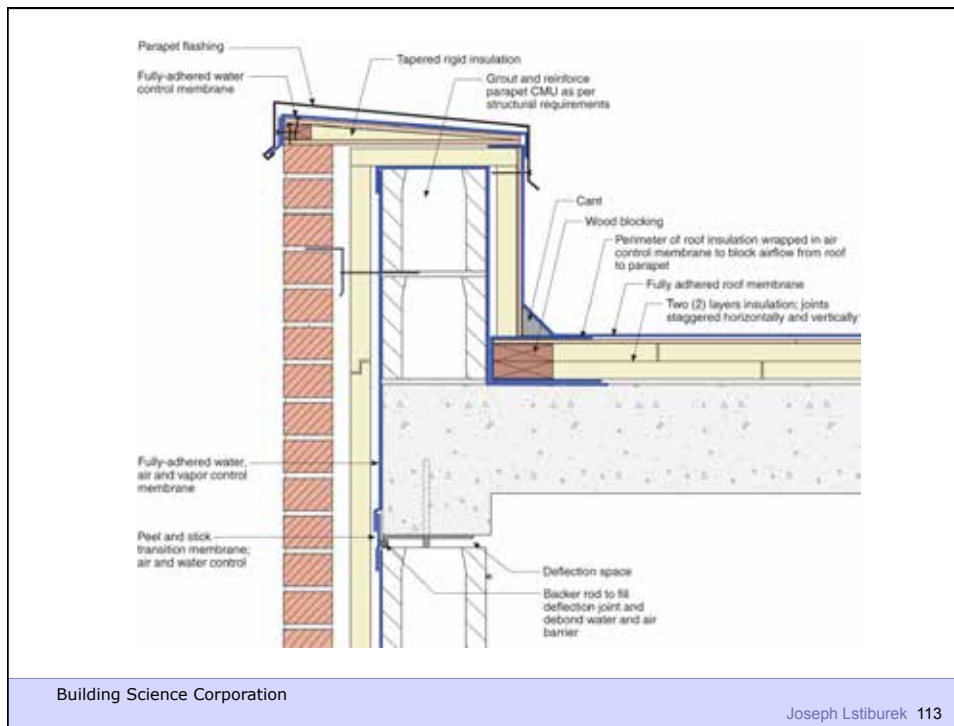

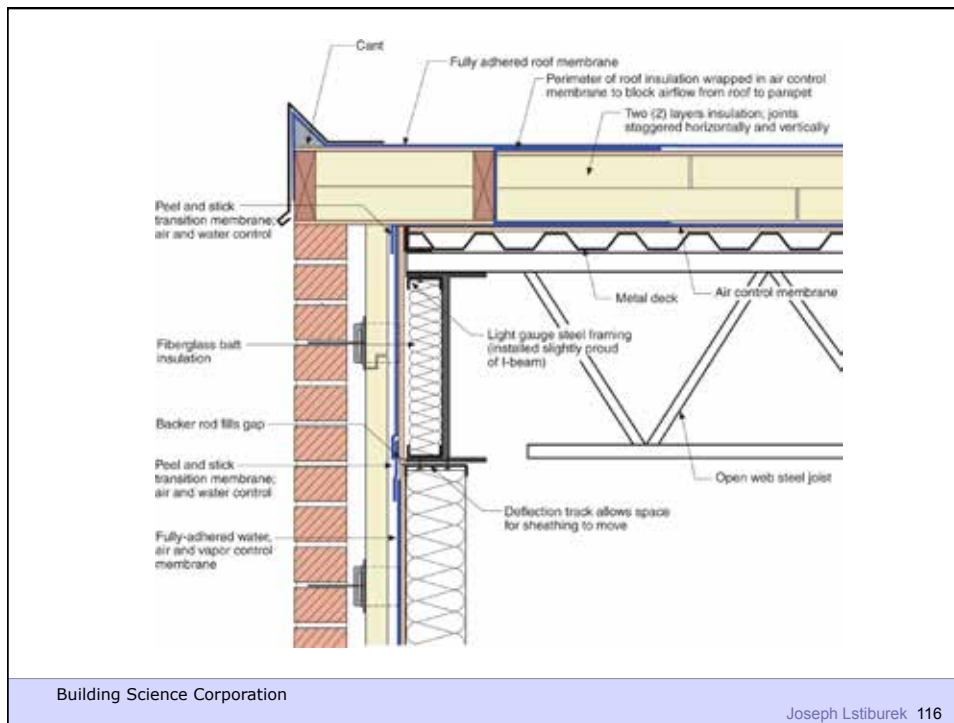
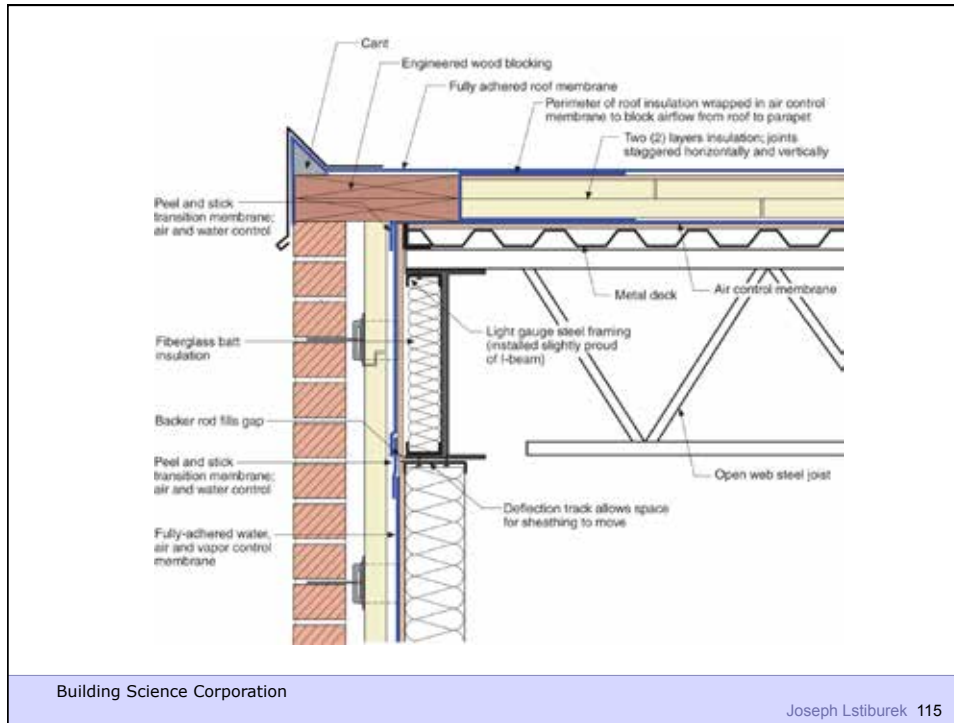

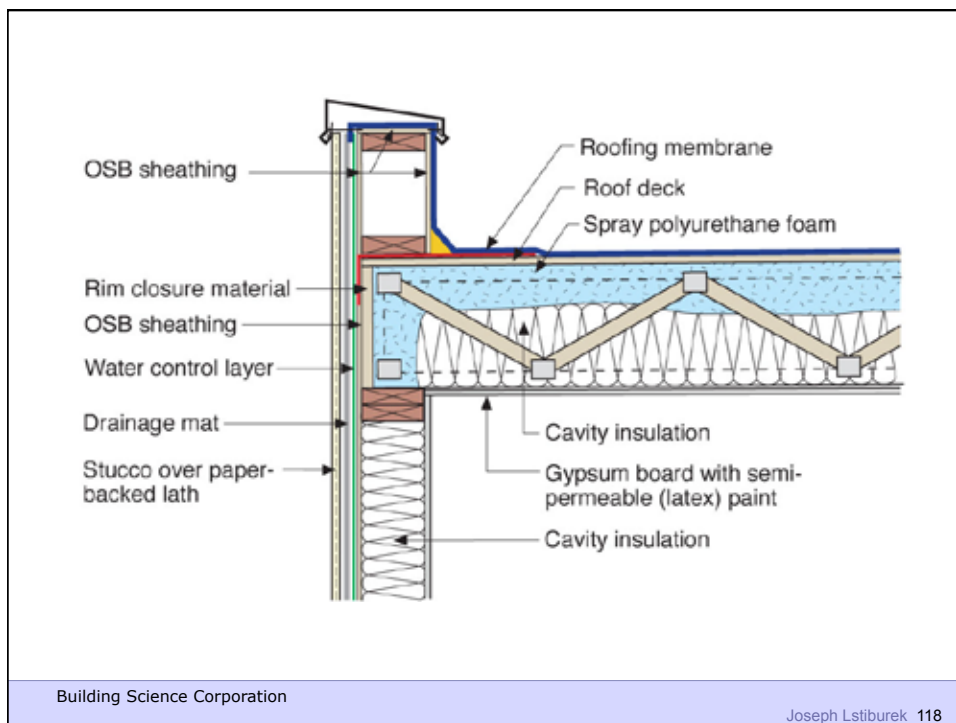
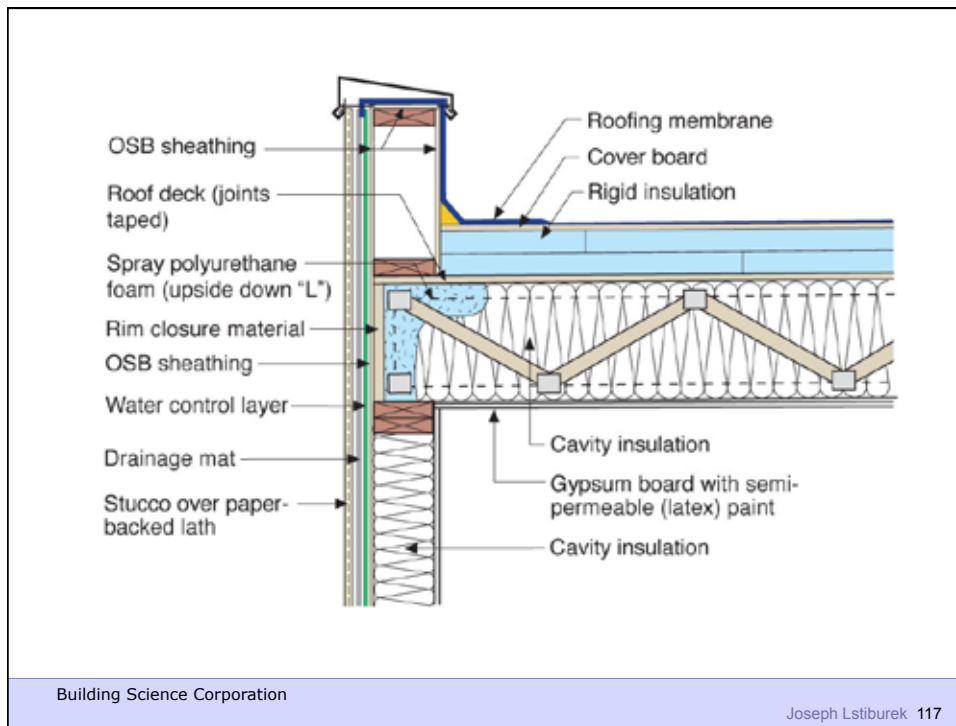

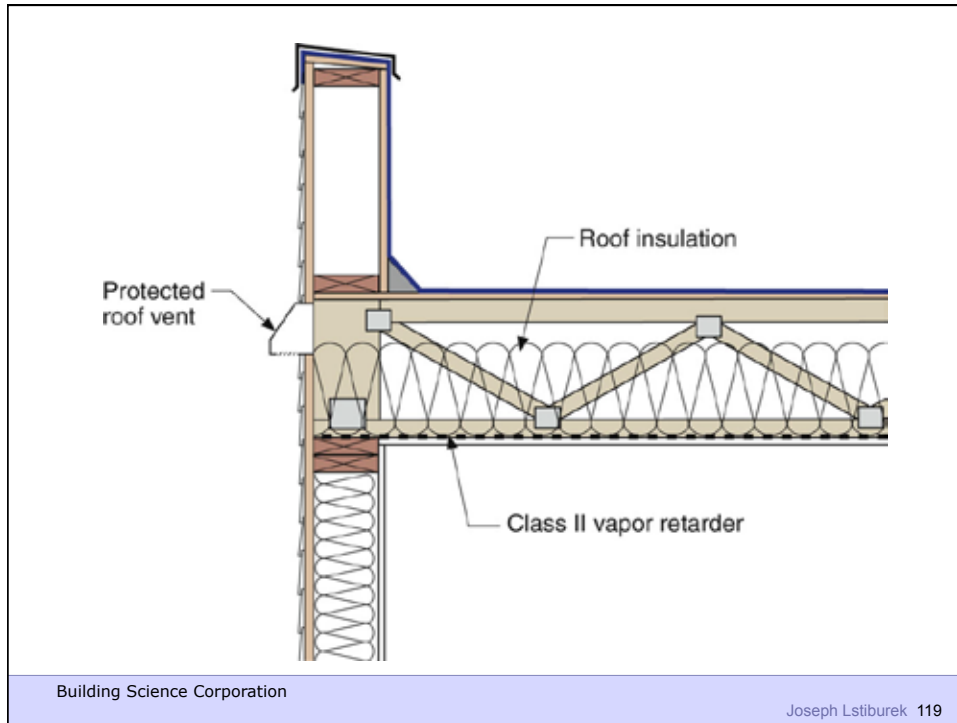



Building Science Corporation

Joseph Lstiburek 121



Building Science Corporation

Joseph Lstiburek 122



Building Science Corporation

Joseph Lstiburek 123



Building Science Corporation

Joseph Lstiburek 124



Building Science Corporation

Joseph Lstiburek 125



Building Science Corporation

Joseph Lstiburek 126



Building Science Corporation

Joseph Lstiburek 127