

Joseph Lstiburek, Ph.D., P.Eng, ASHRAE Fellow

Building Science

Adventures In Building Science

www.buildingscience.com

2nd Law of Thermodynamics

Building Science Corporation

Joseph Lstiburek 2

Heat Flow Is From Warm To Cold
Moisture Flow Is From Warm To Cold
Moisture Flow Is From More To Less
Air Flow Is From A Higher Pressure to a
Lower Pressure
Gravity Acts Down

Building Science Corporation

Joseph Lstiburek 3



Building Science Corporation

Joseph Lstiburek 4

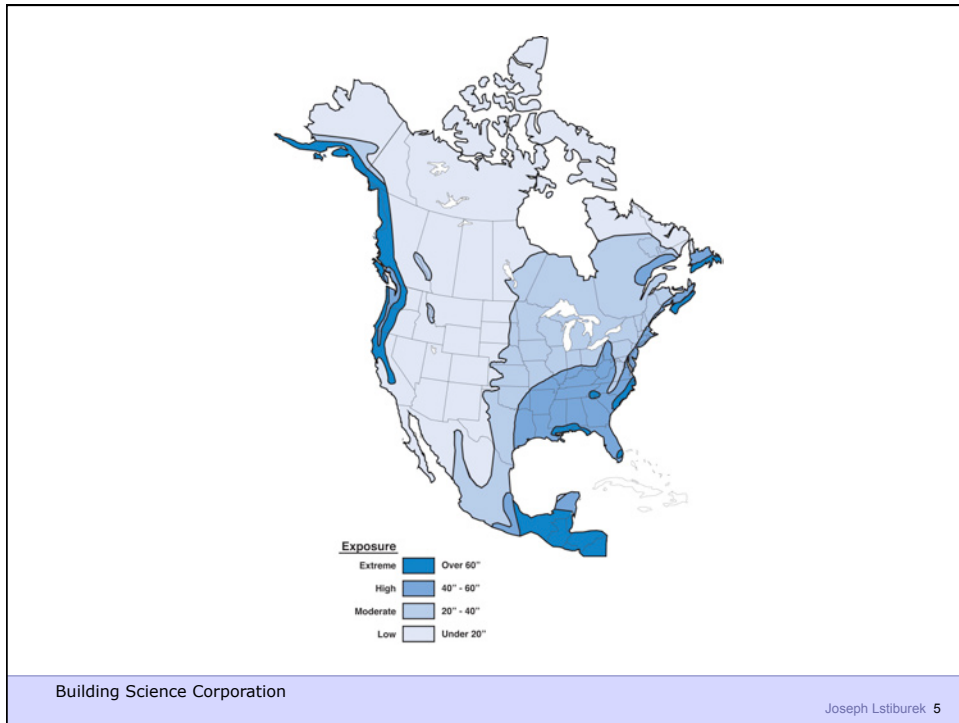

Water Control Layer
Air Control Layer
Vapor Control Layer
Thermal Control Layer

Building Science Corporation

Joseph Lstiburek 6

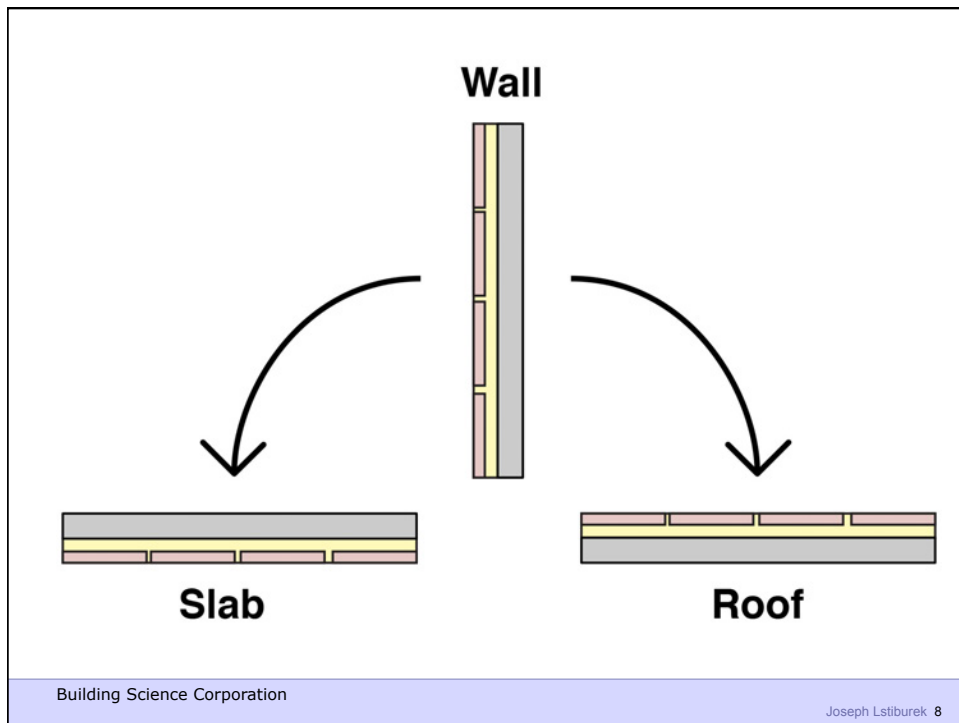
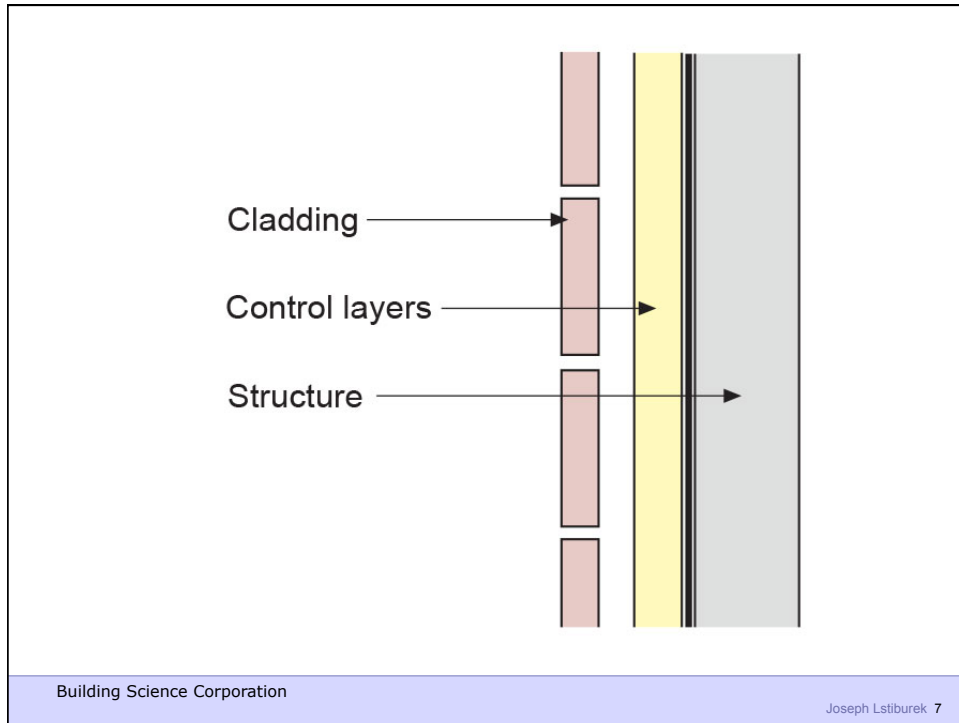

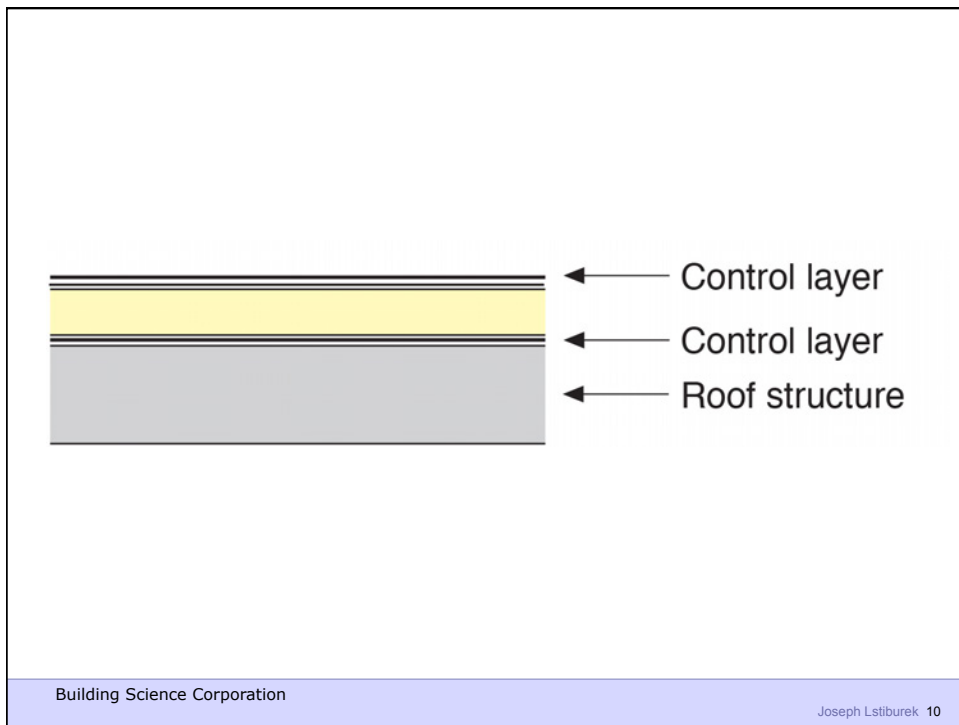
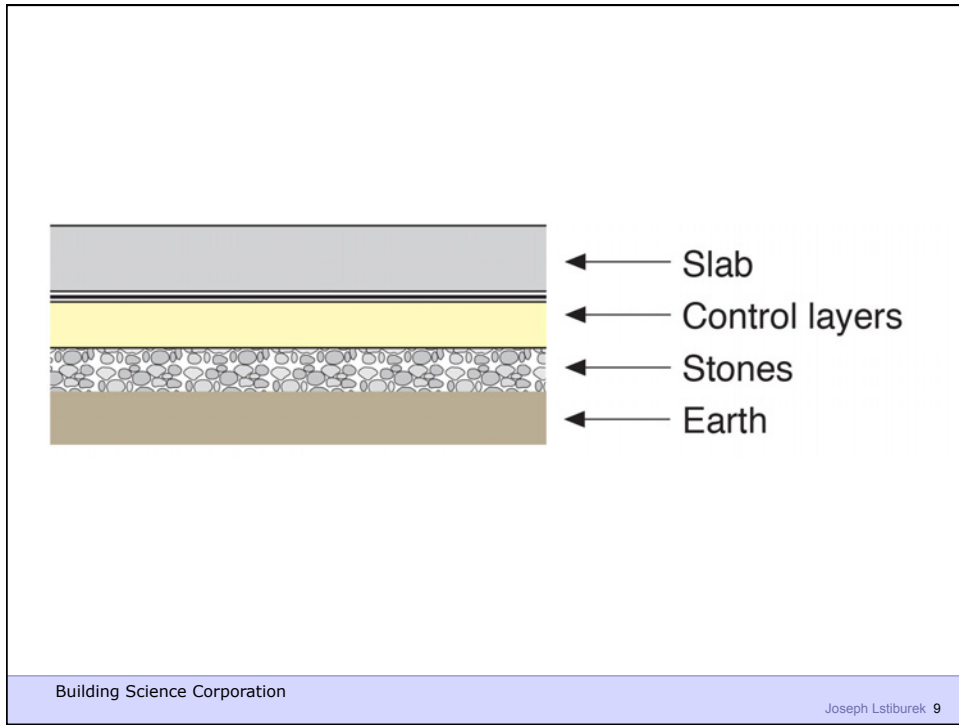

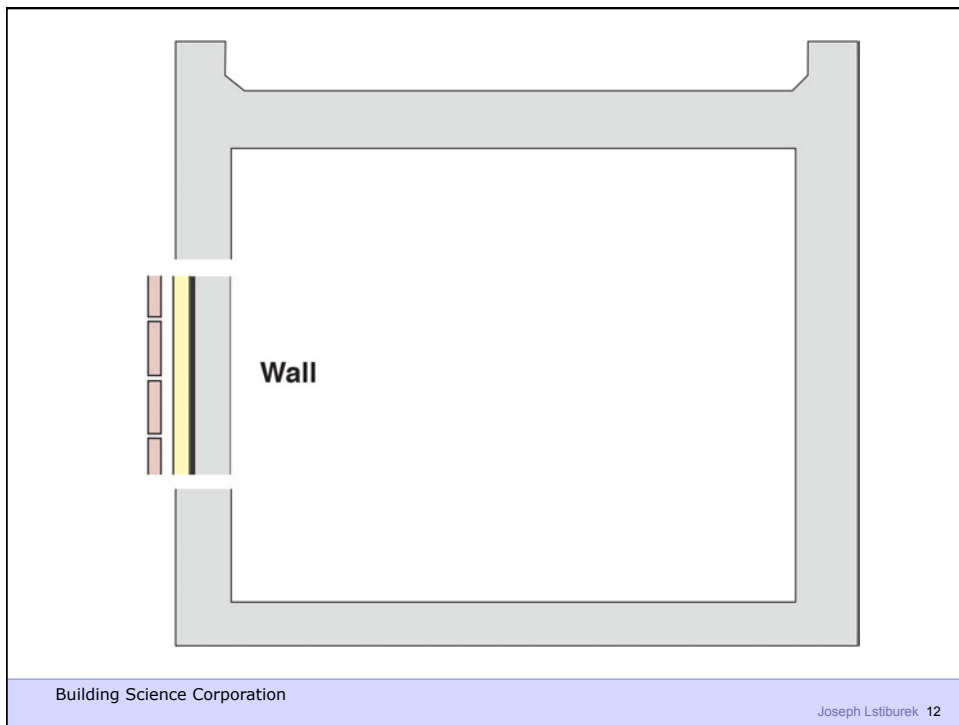
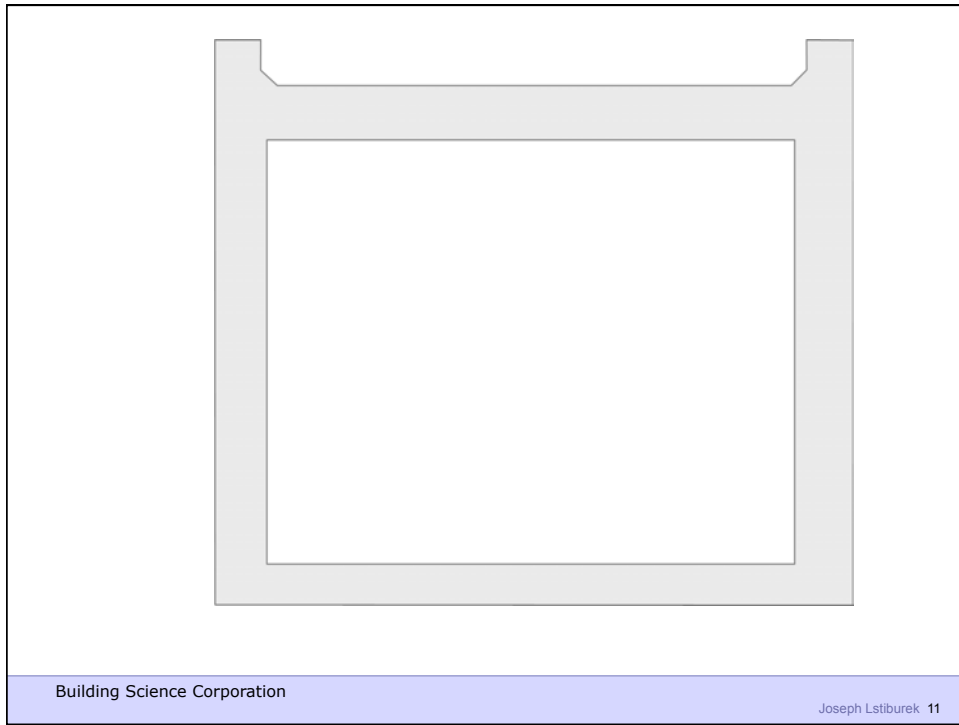

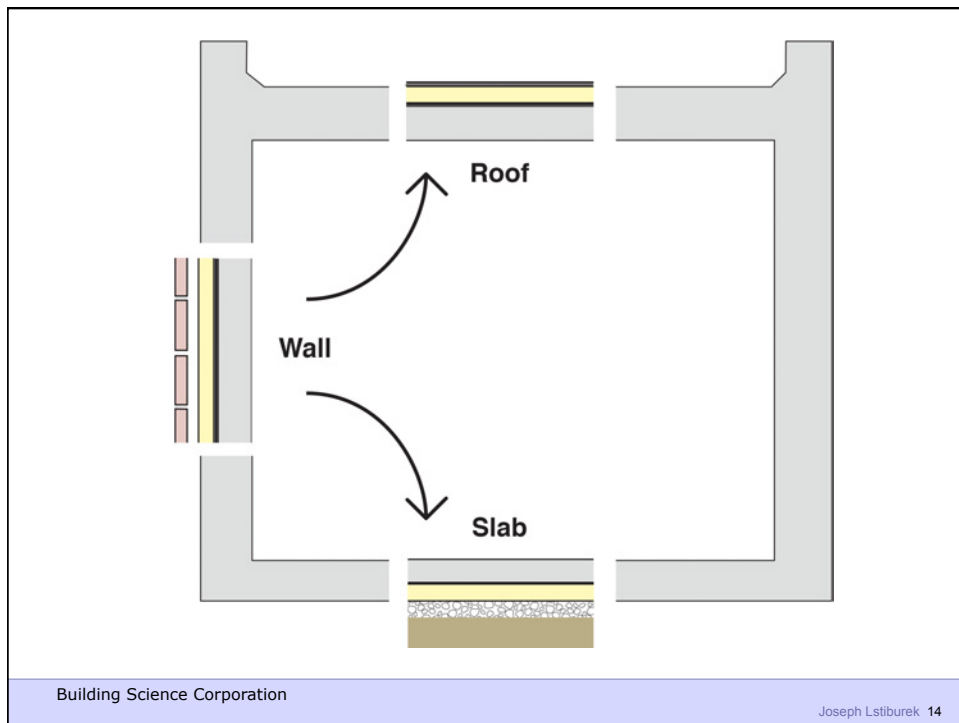
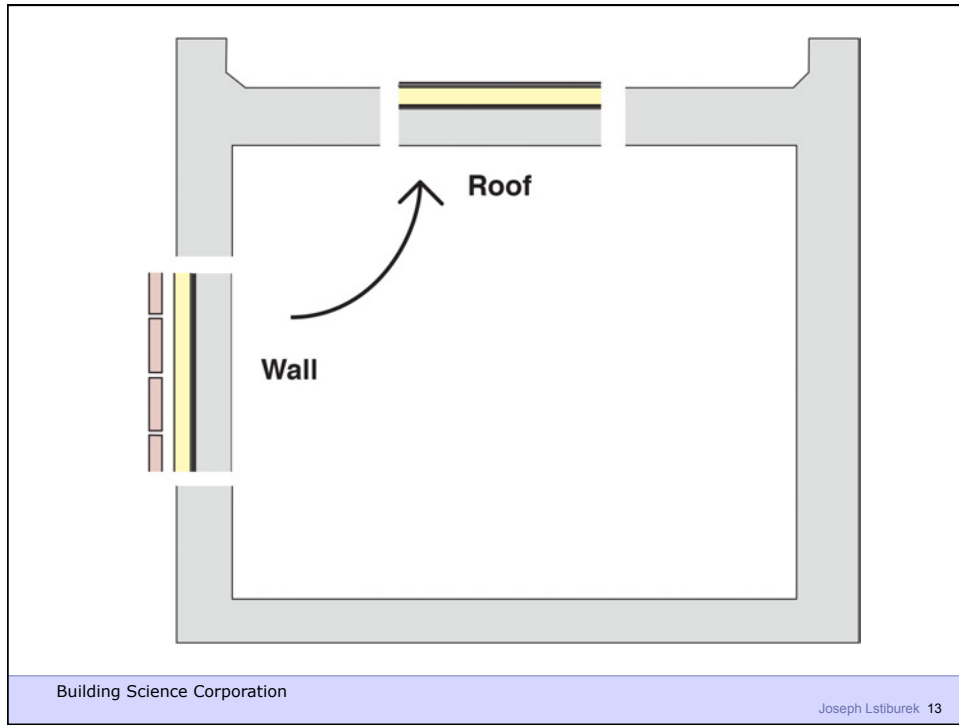

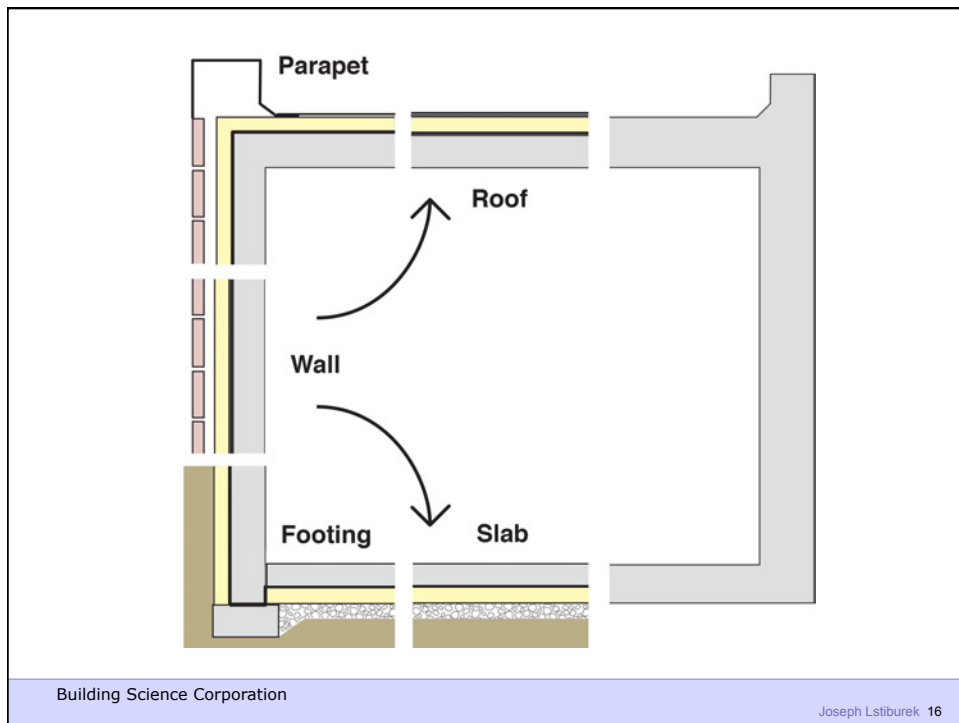
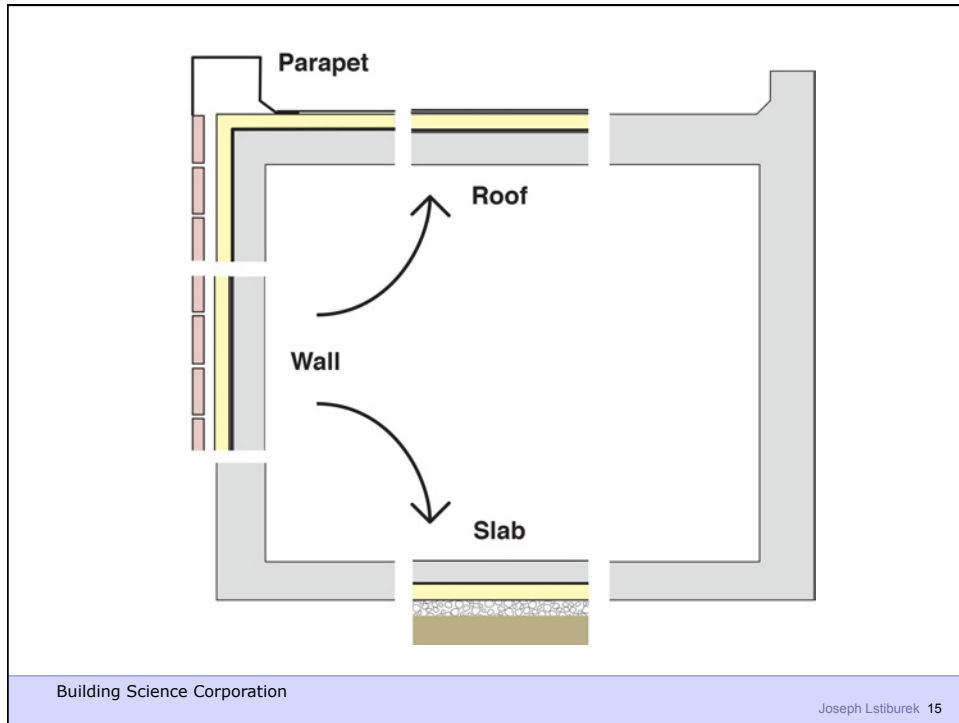

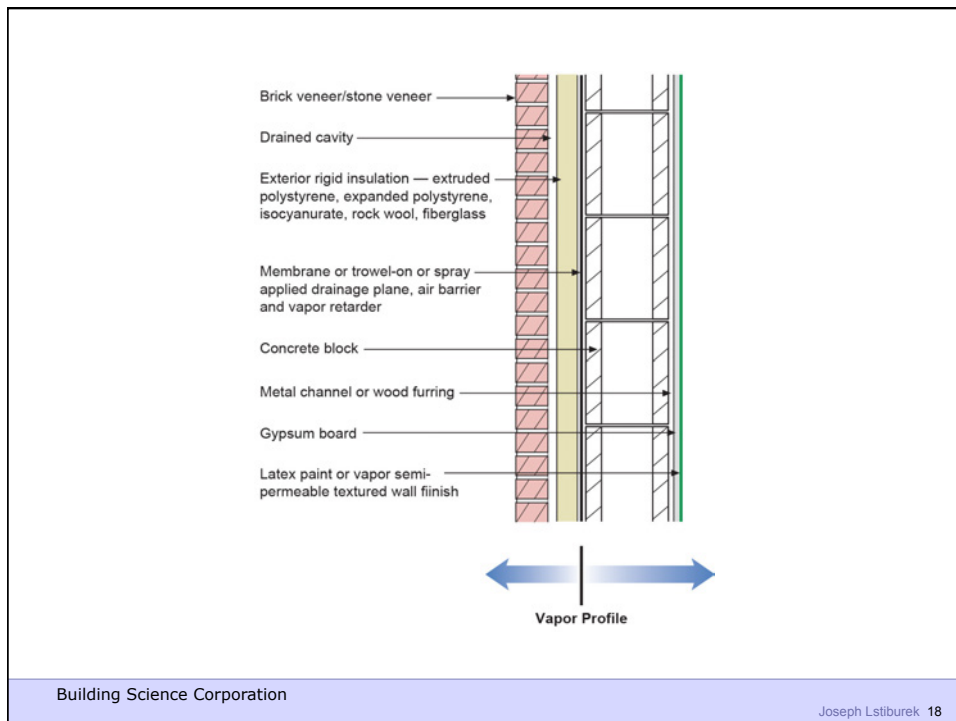
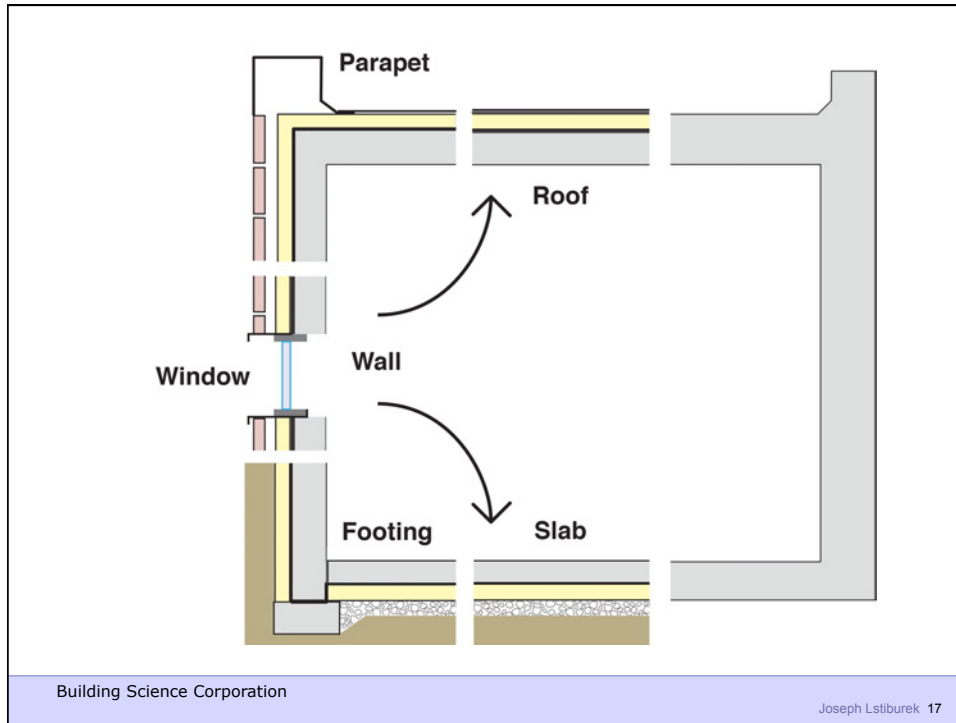

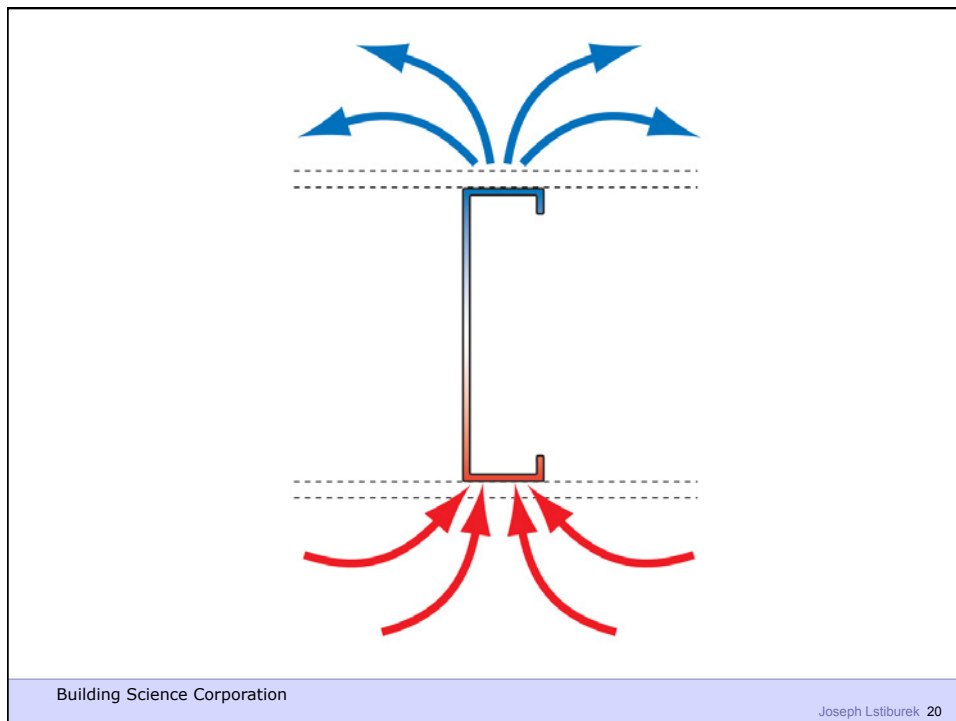
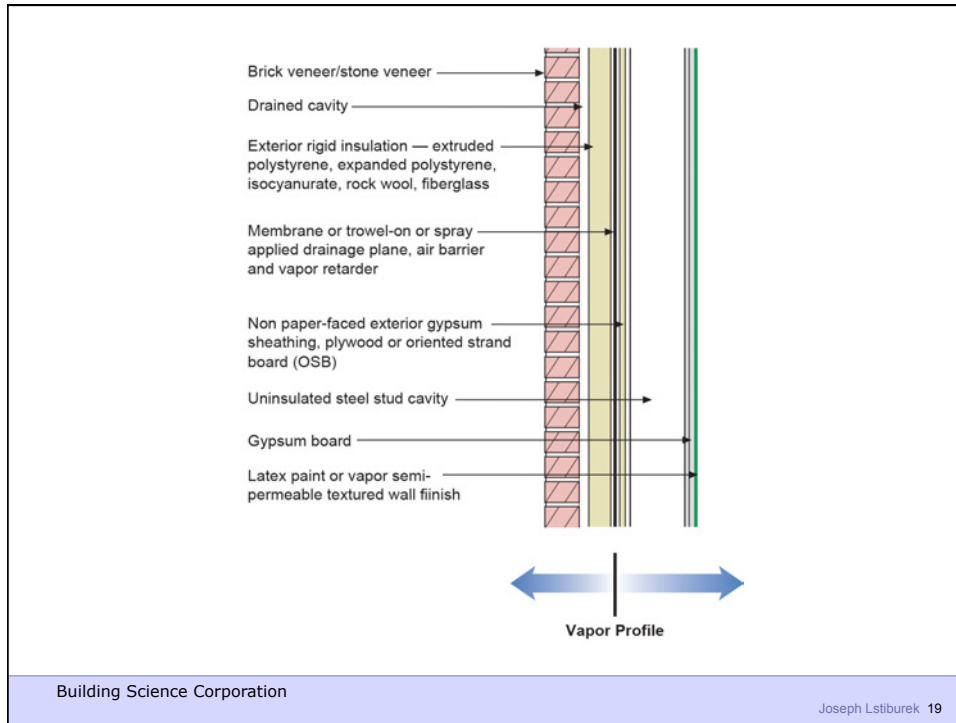

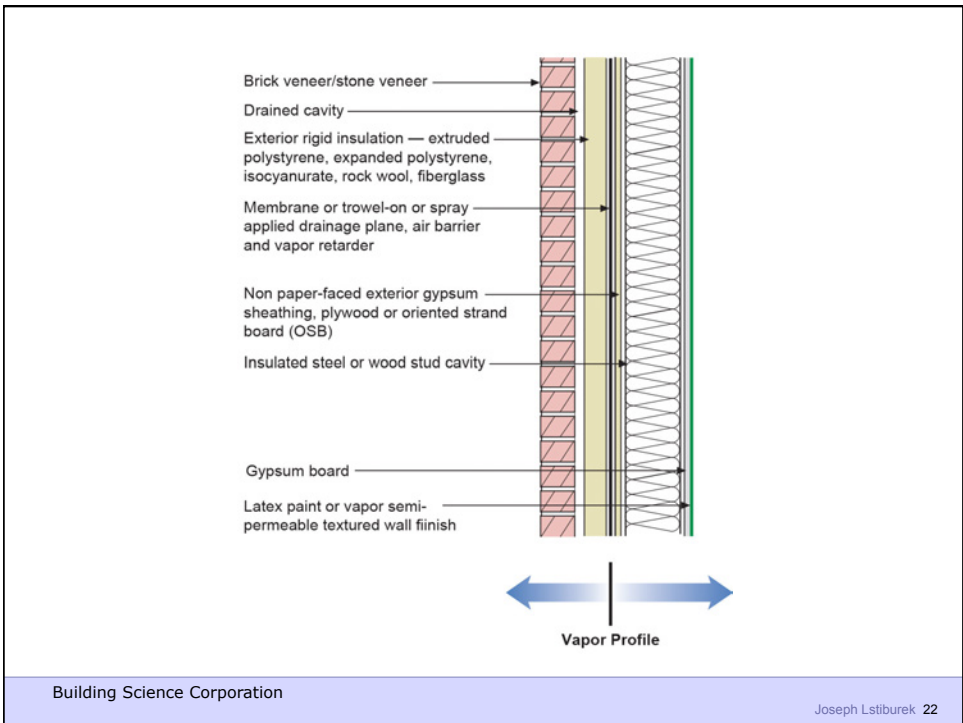

Florida

Building Science Corporation

Joseph Lstiburek 23

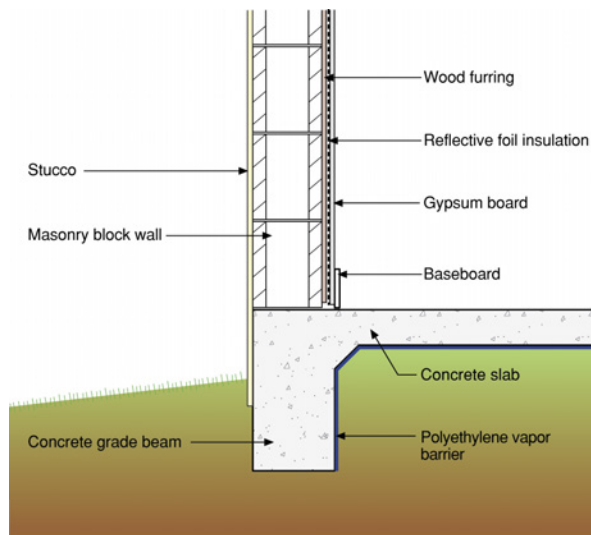

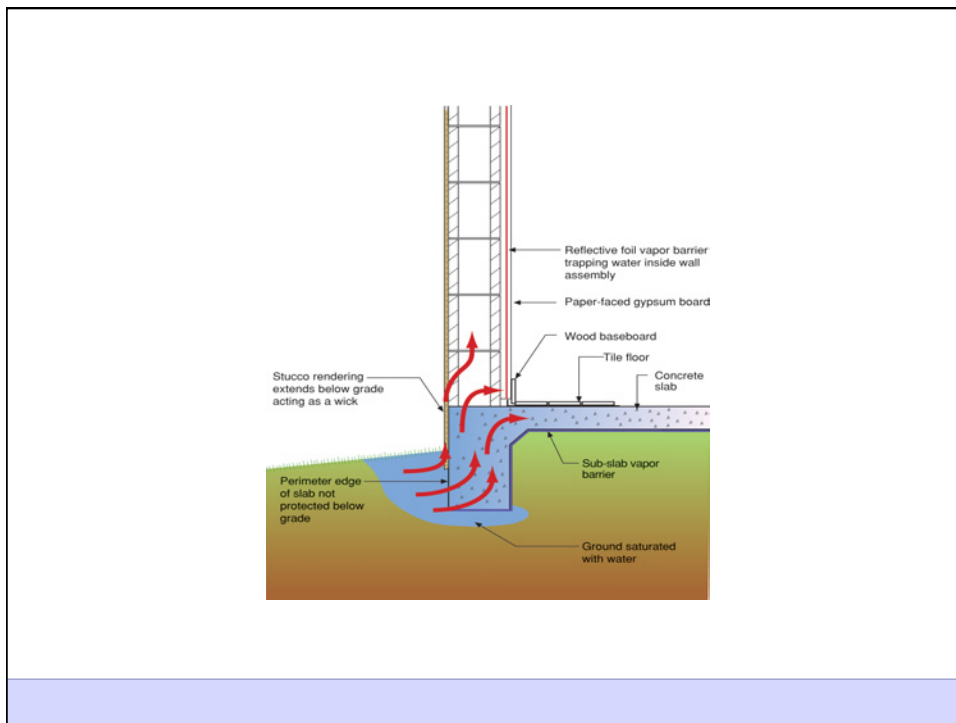
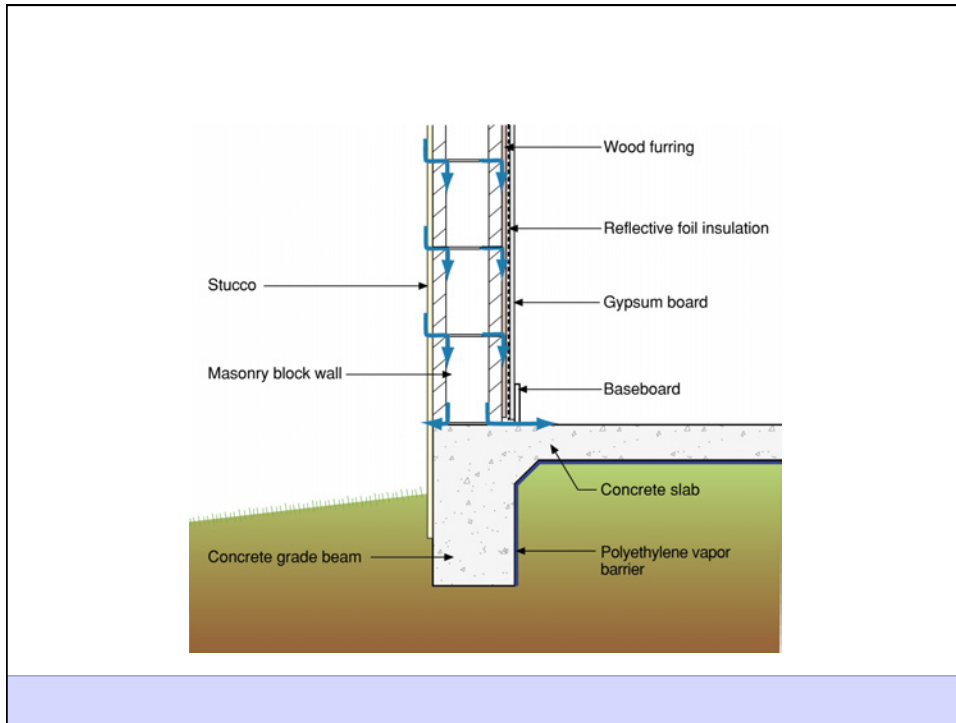

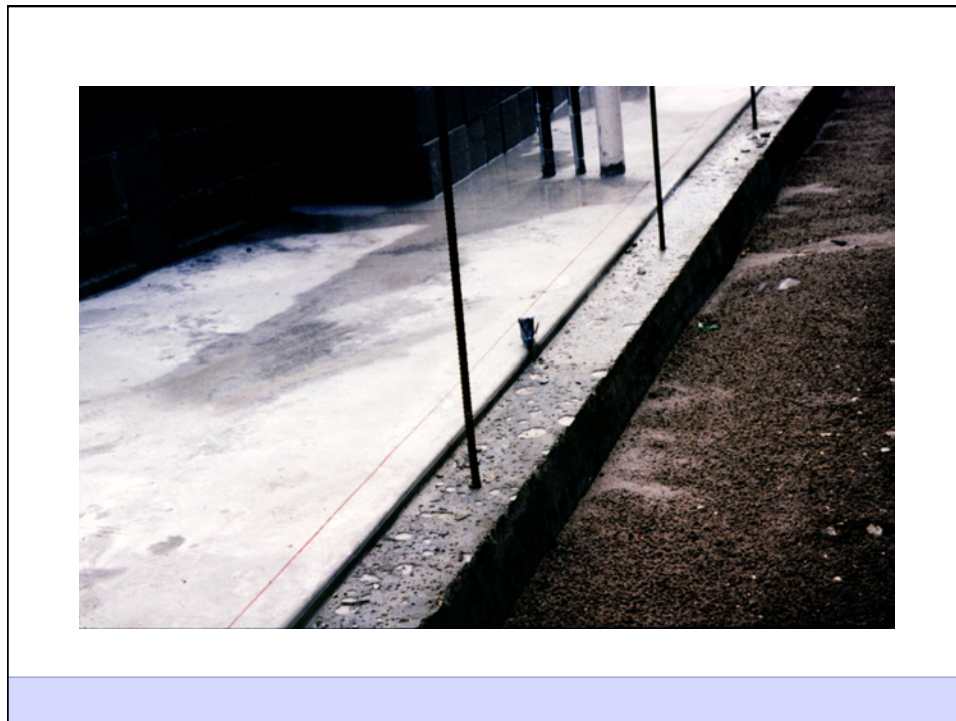
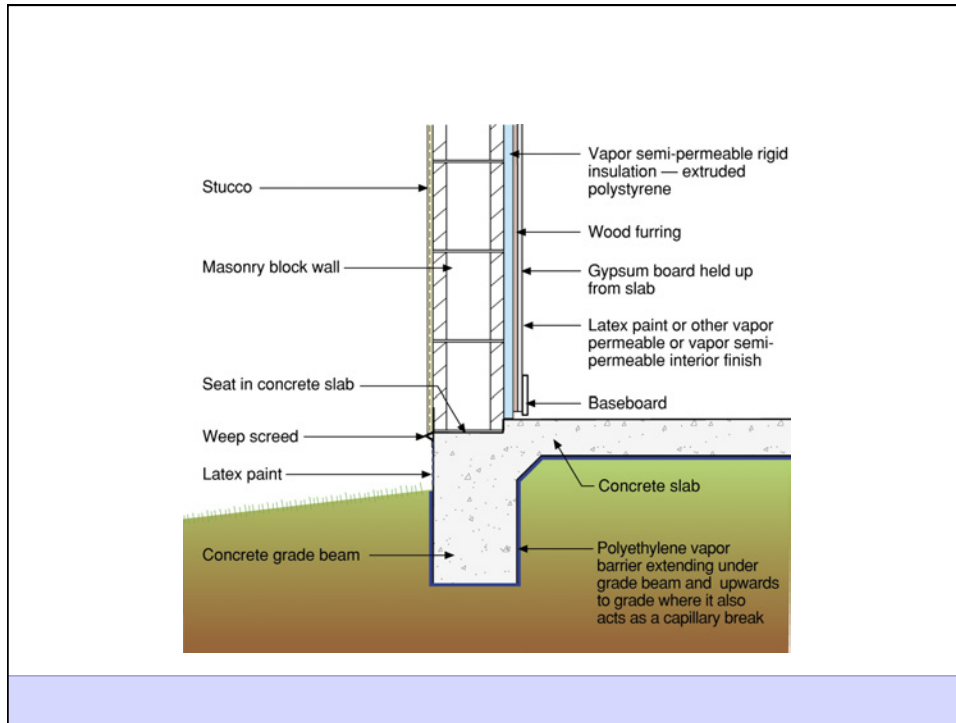

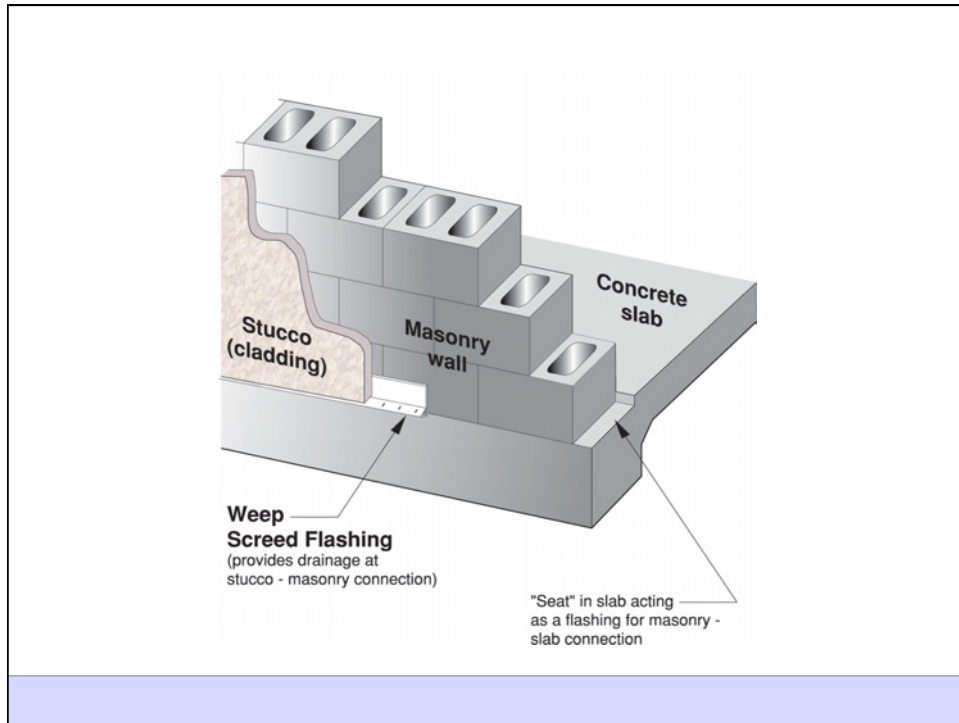

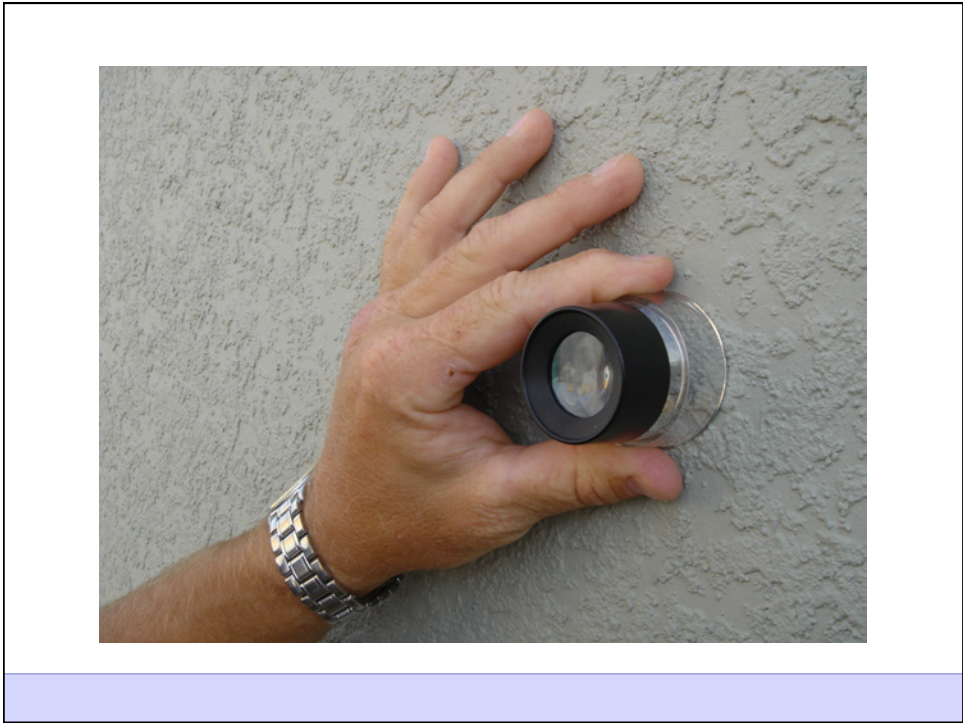

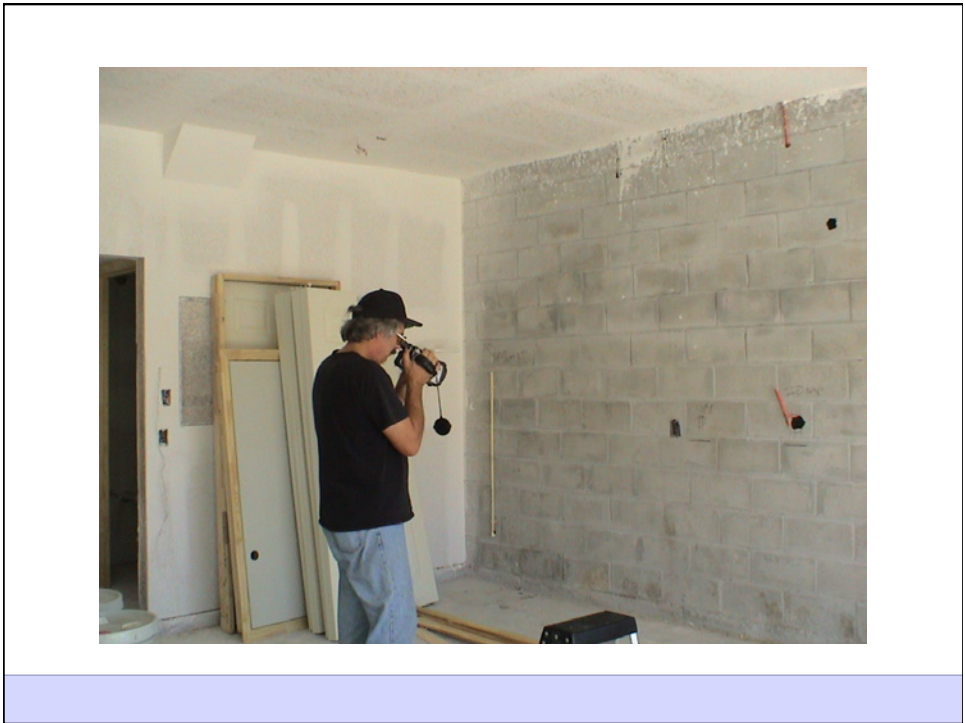

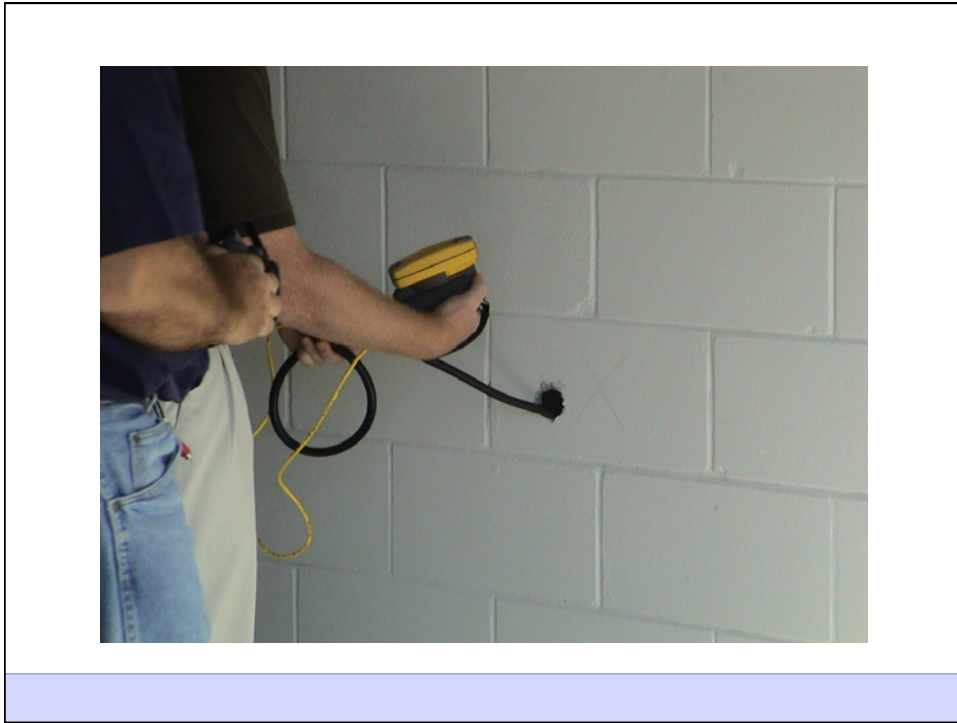

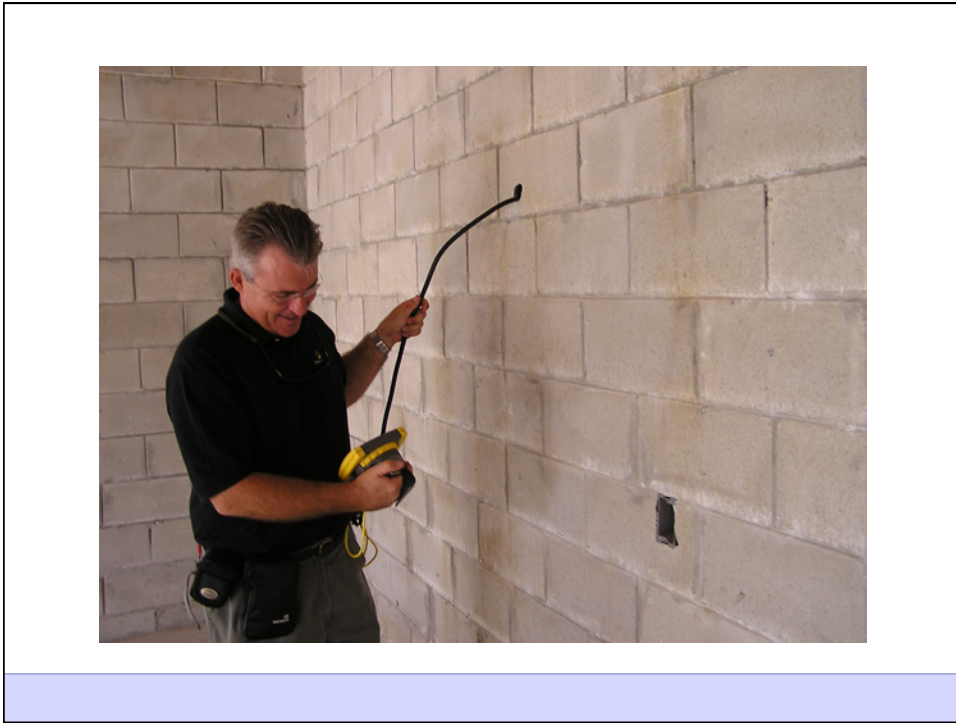

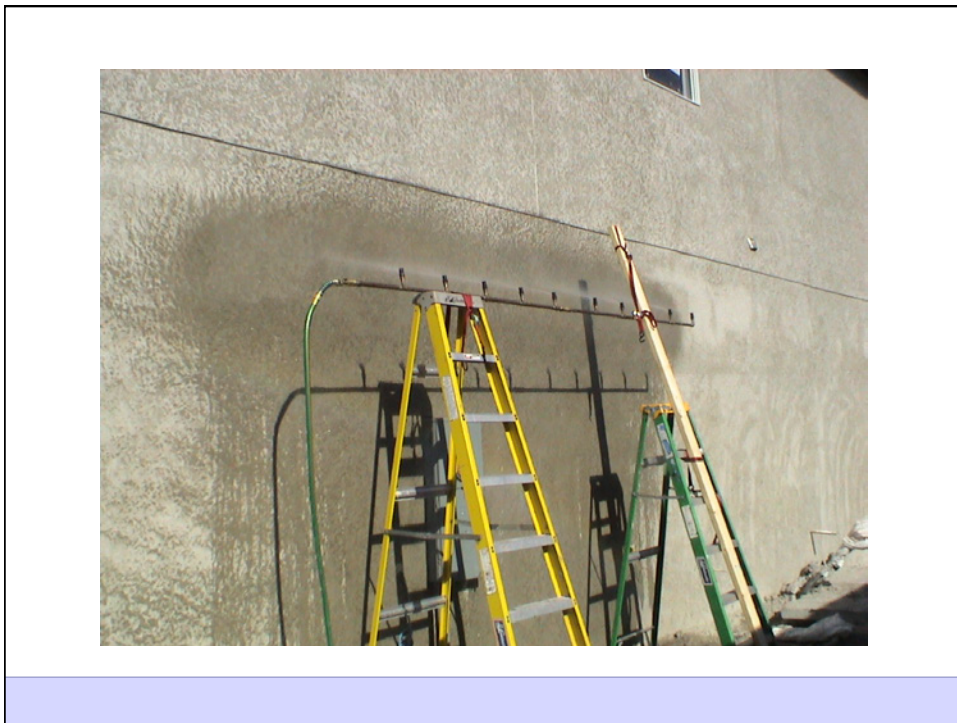

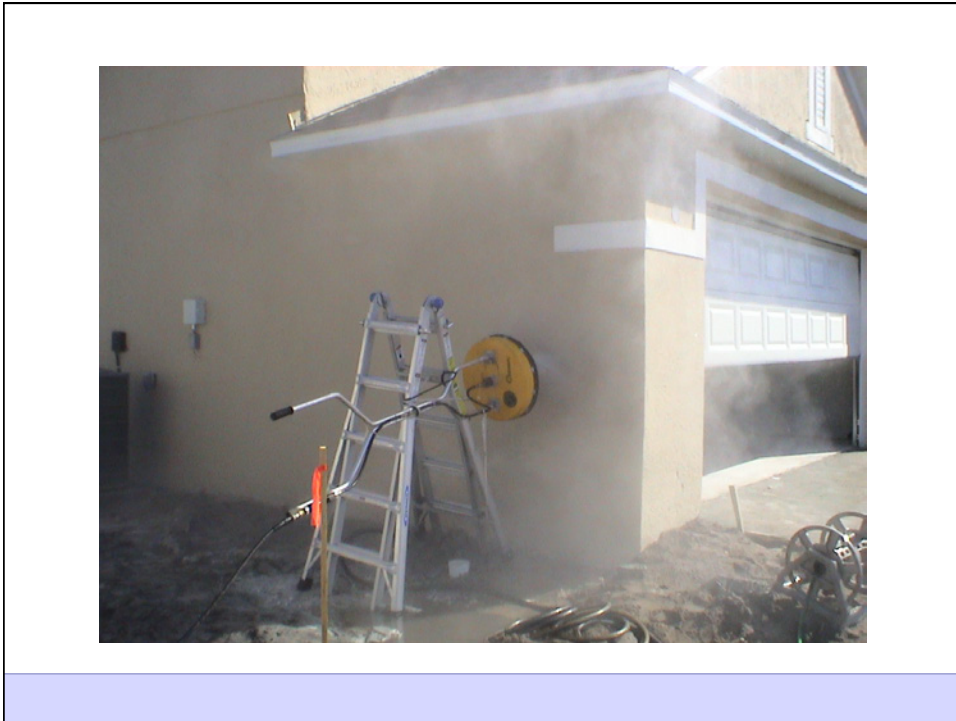



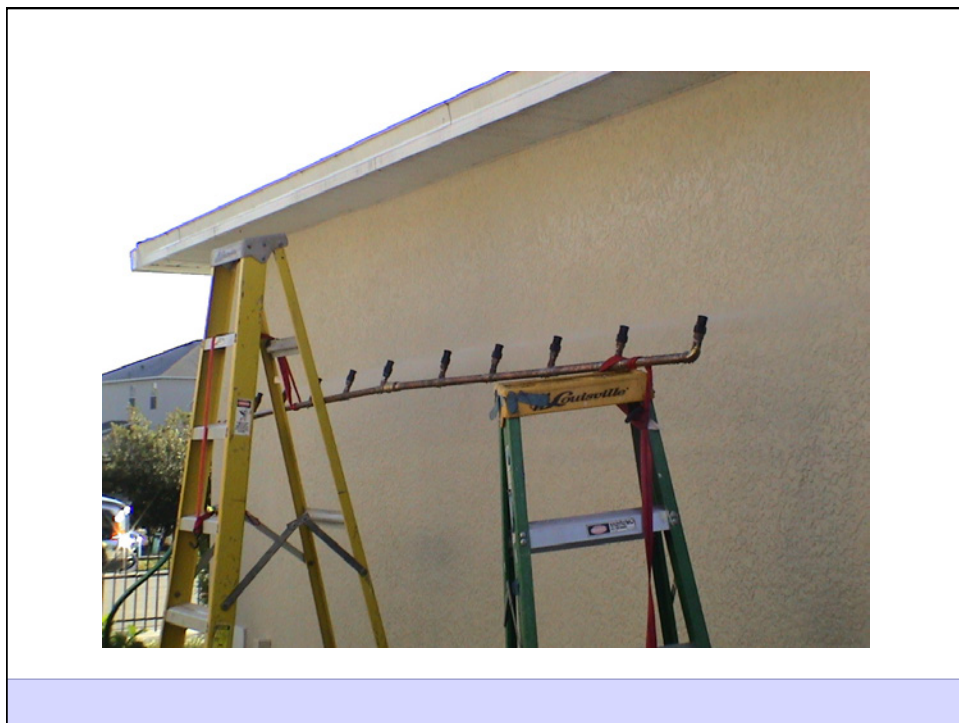

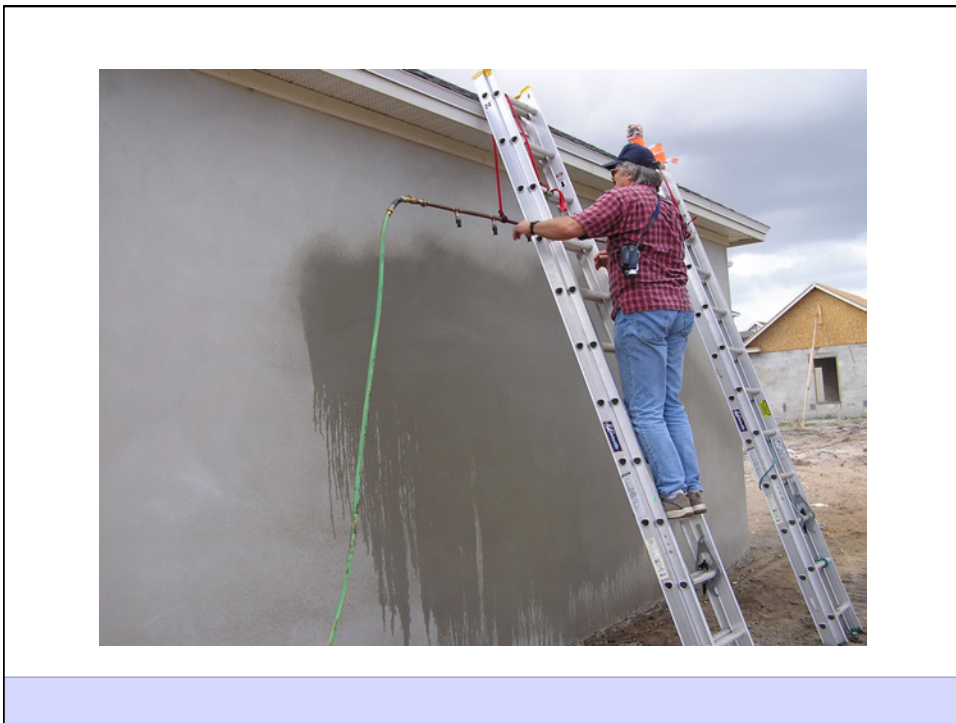
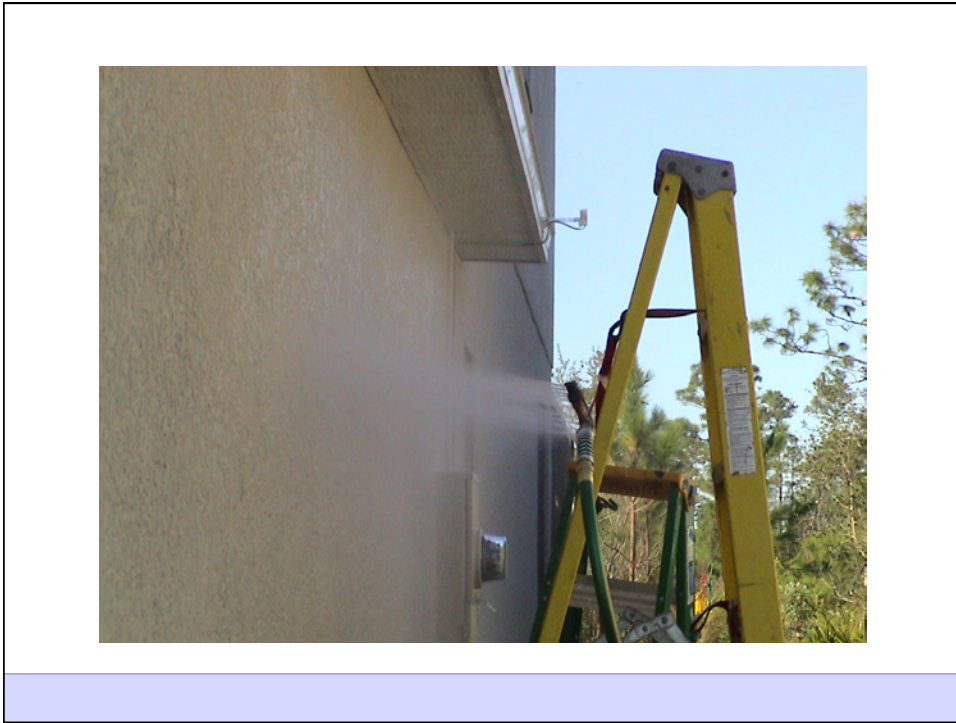











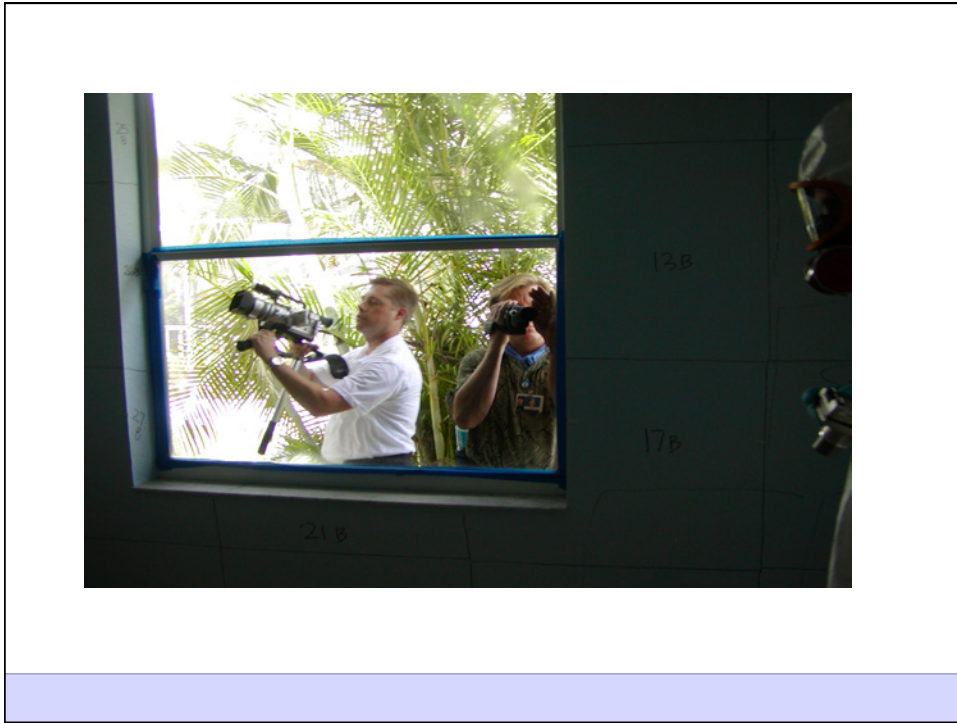

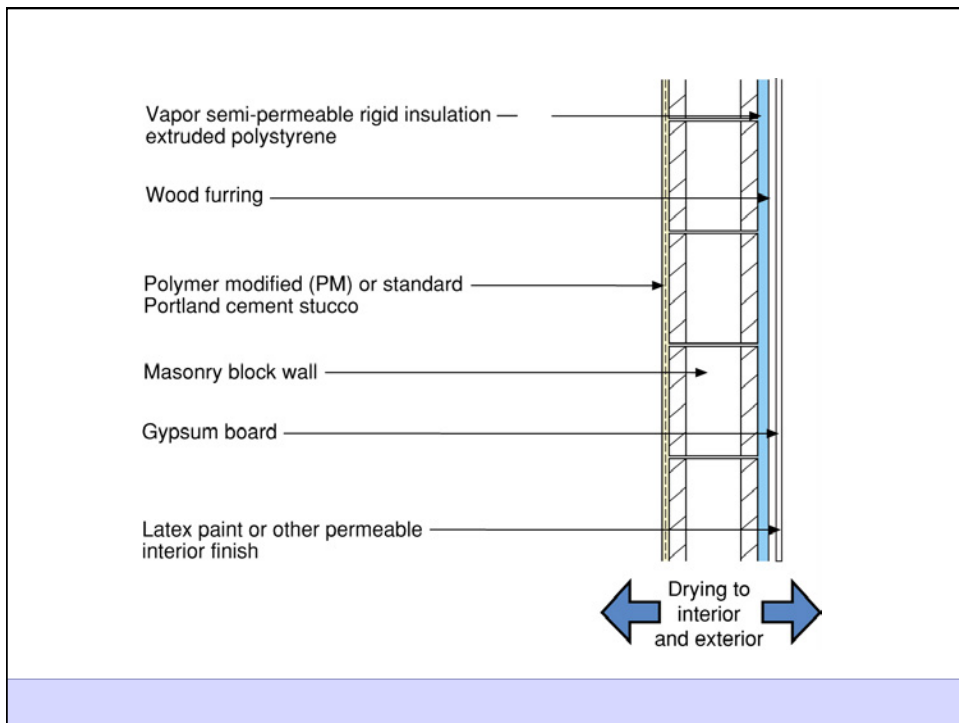





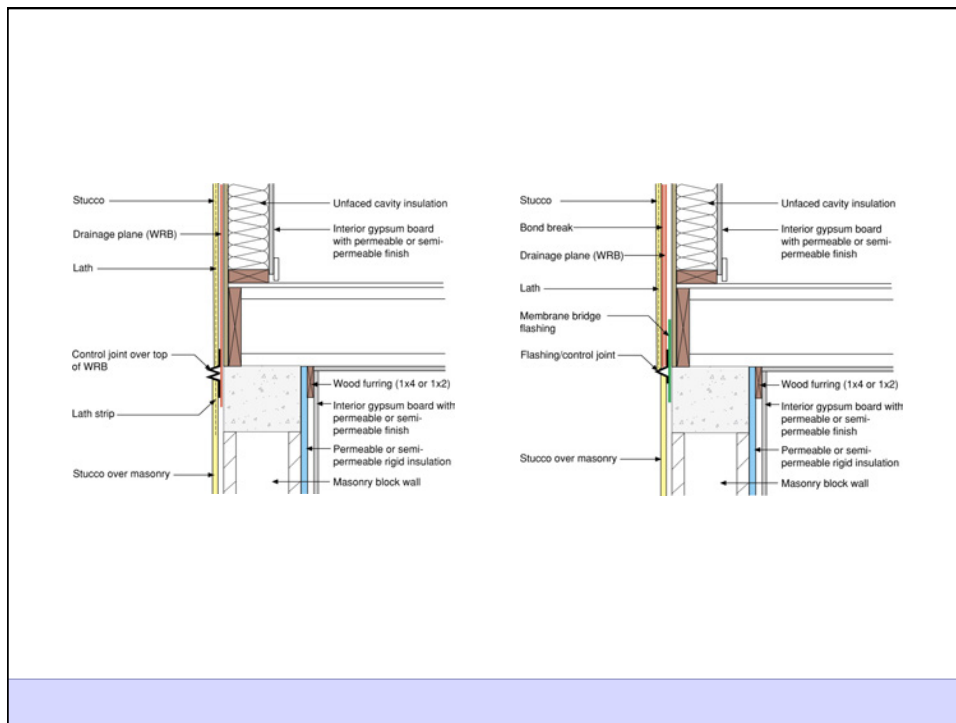
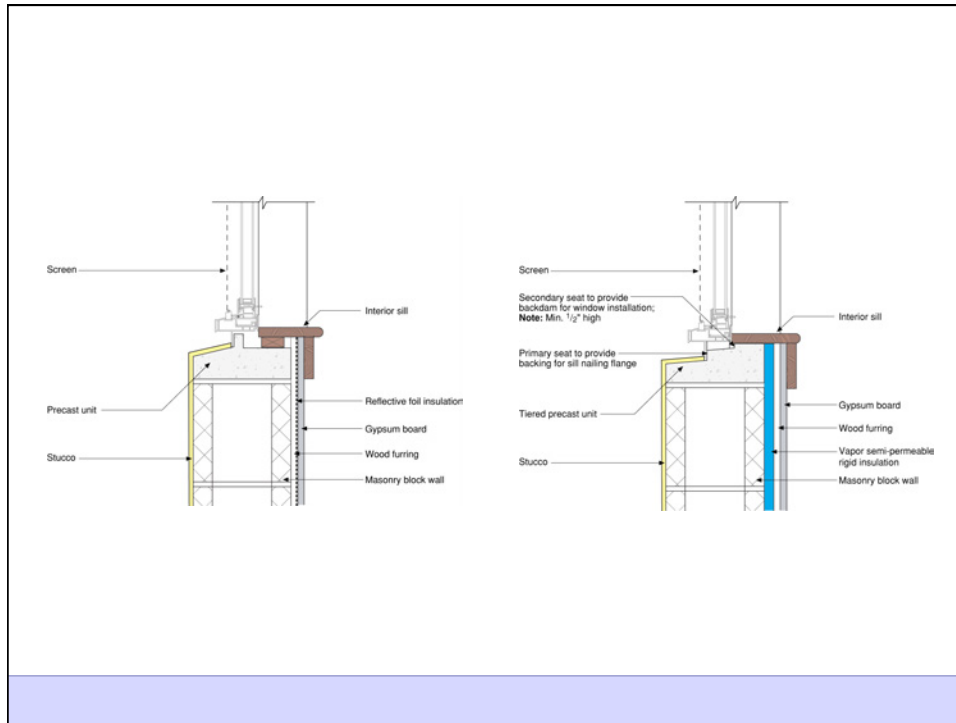



Building Science 2009

Joseph Lstiburek 69



Building Science 2009

Joseph Lstiburek 70



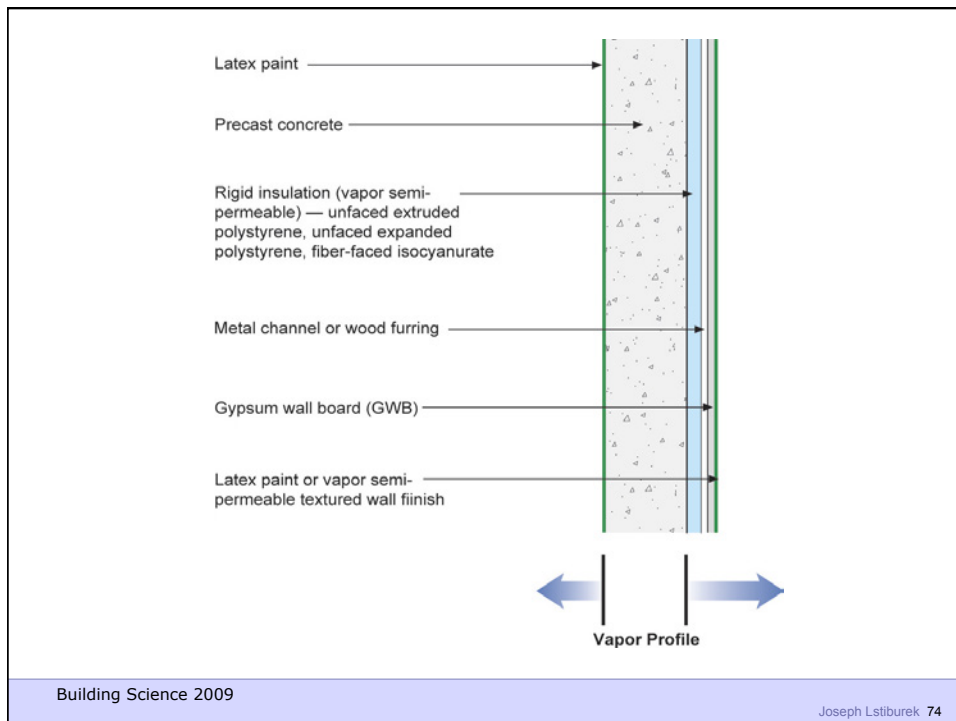
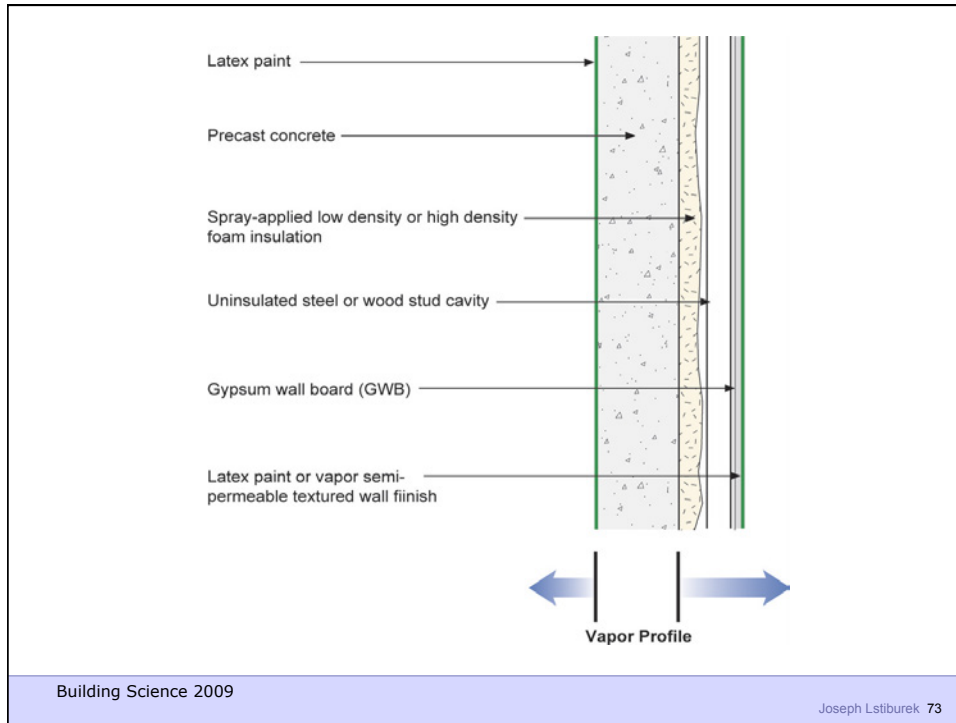

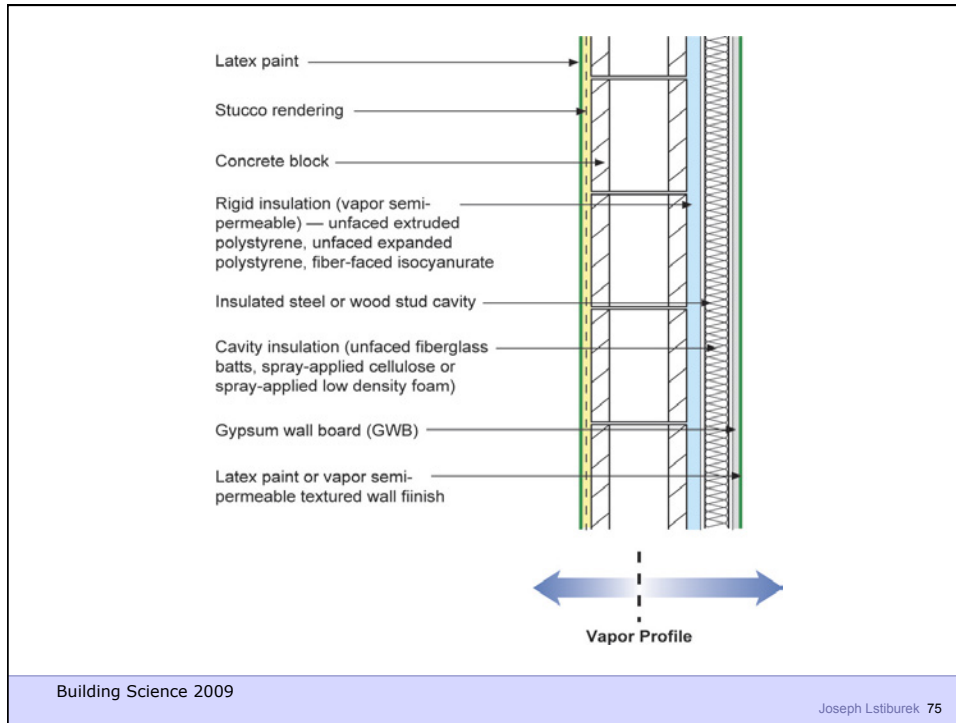



Building Science 2009

Joseph Lstiburek 77



Building Science 2009

Joseph Lstiburek 78



Building Science 2009

Joseph Lstiburek 79



Building Science 2009

Joseph Lstiburek 80

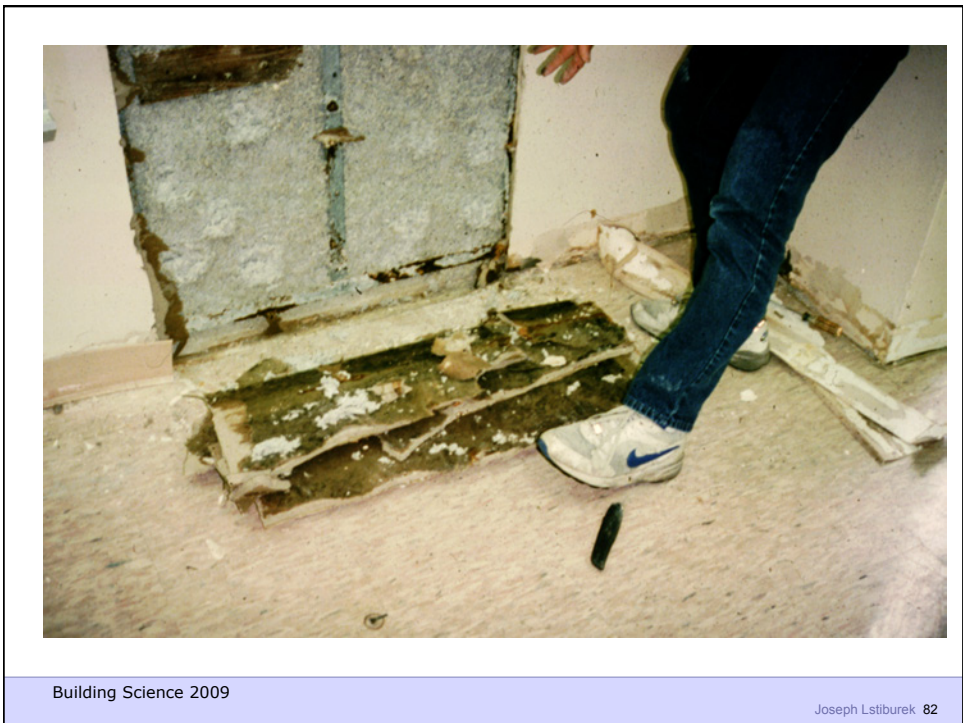







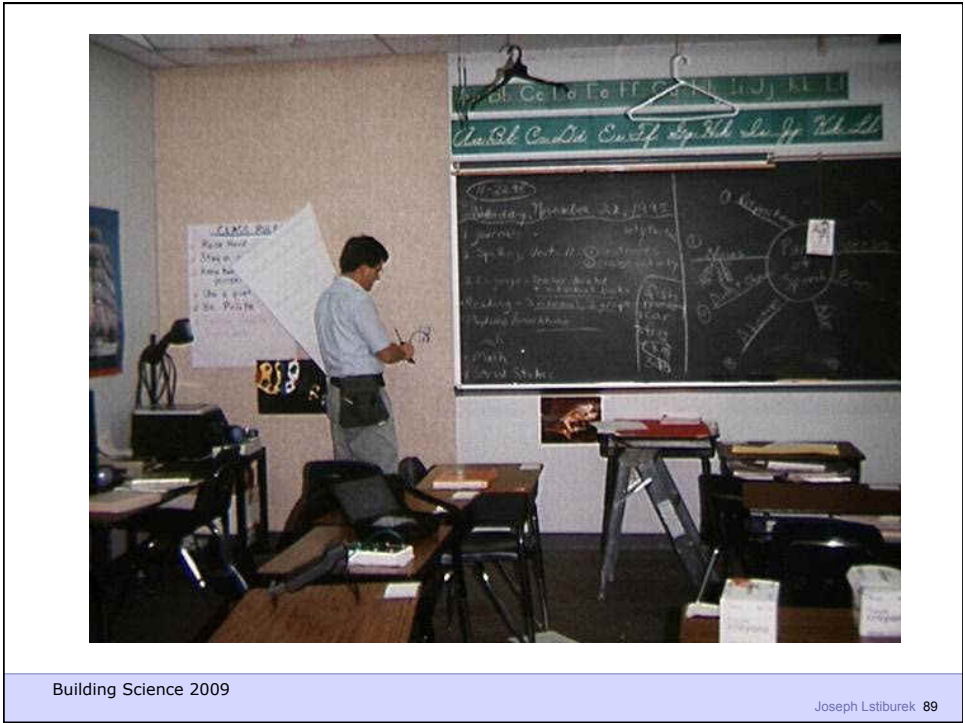







Building Science 2009

Joseph Lstiburek 95



Building Science 2009

Joseph Lstiburek 96





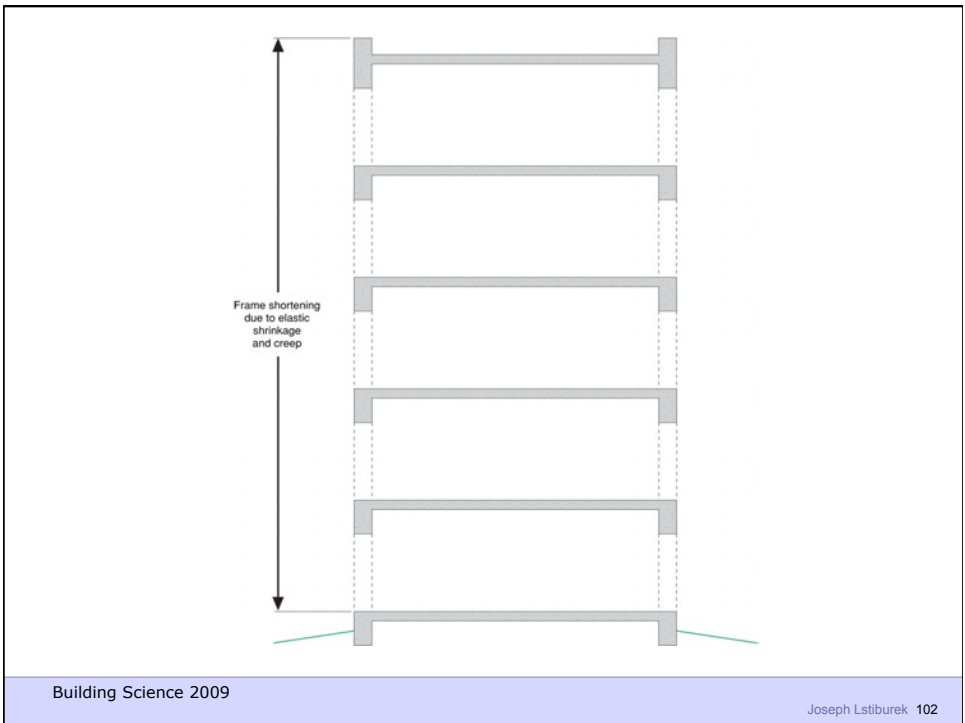

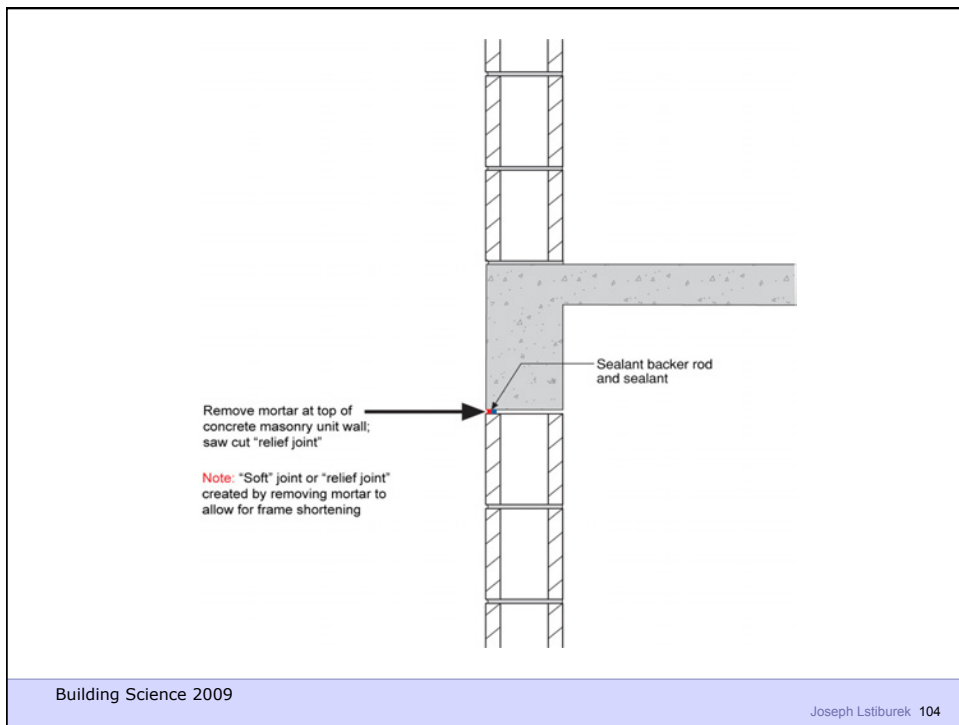
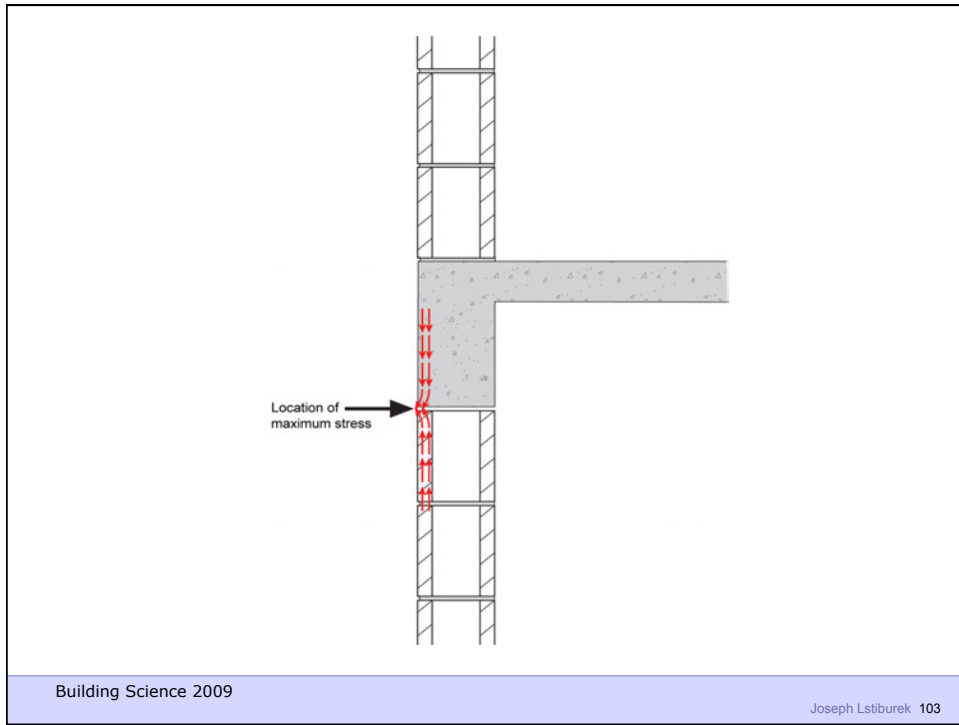

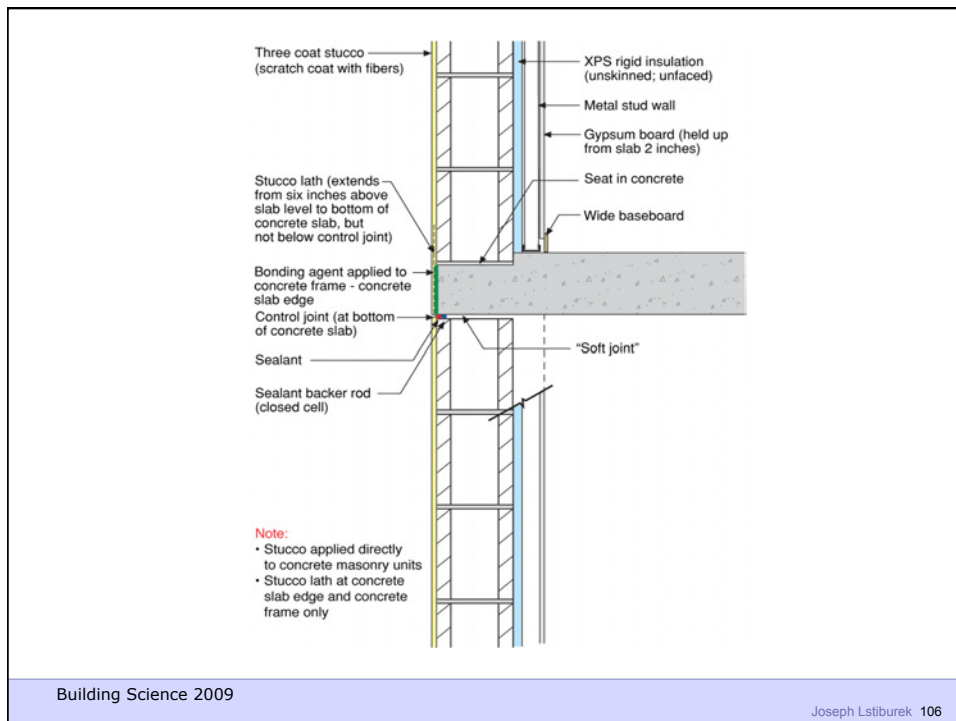
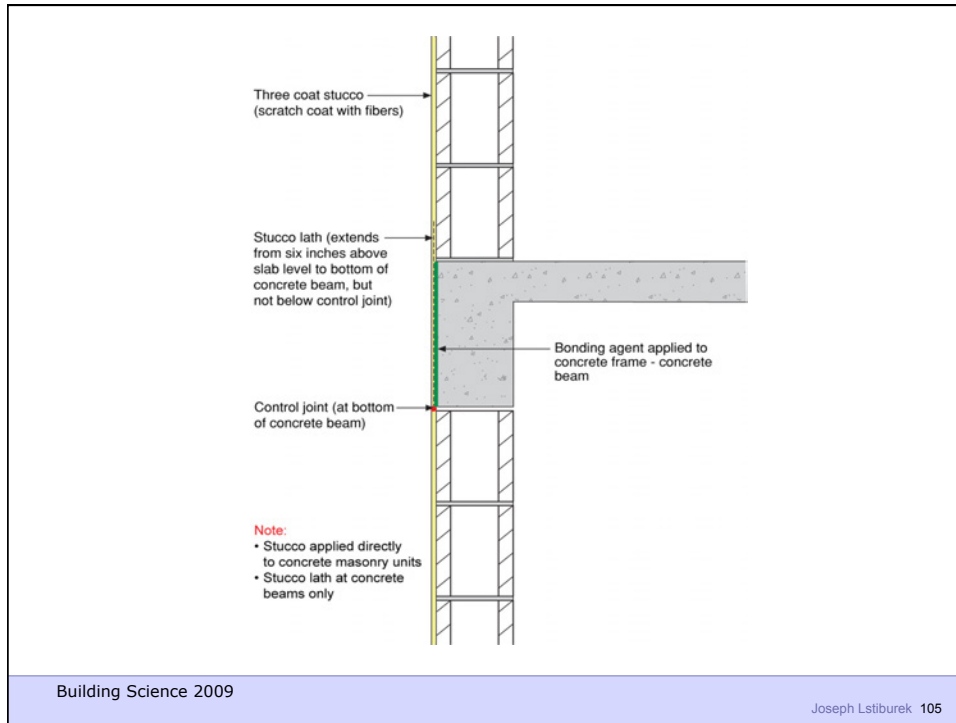

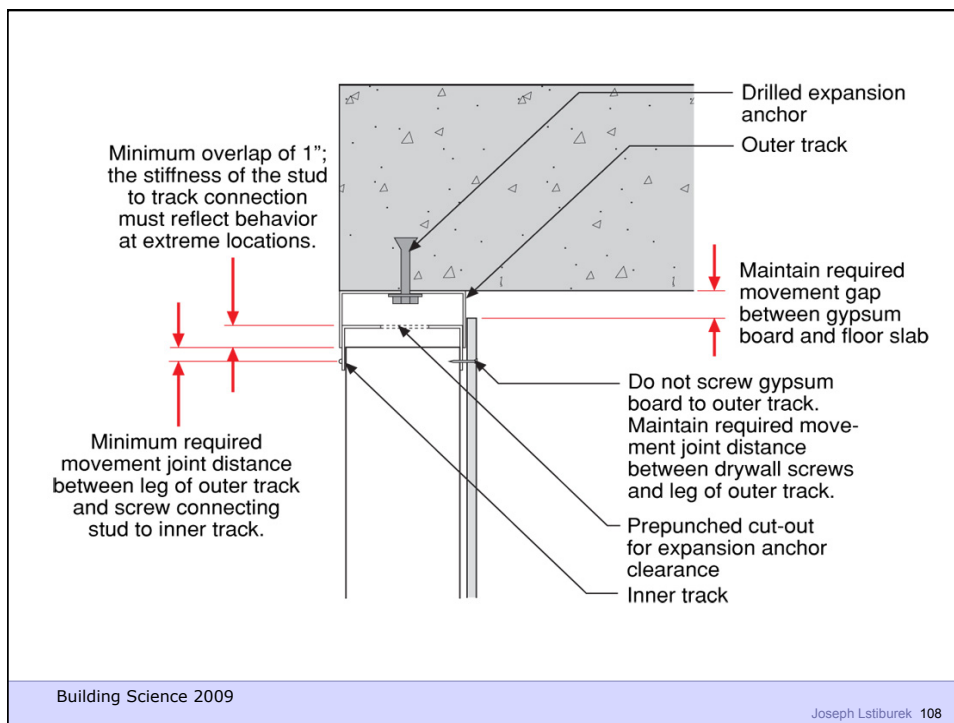
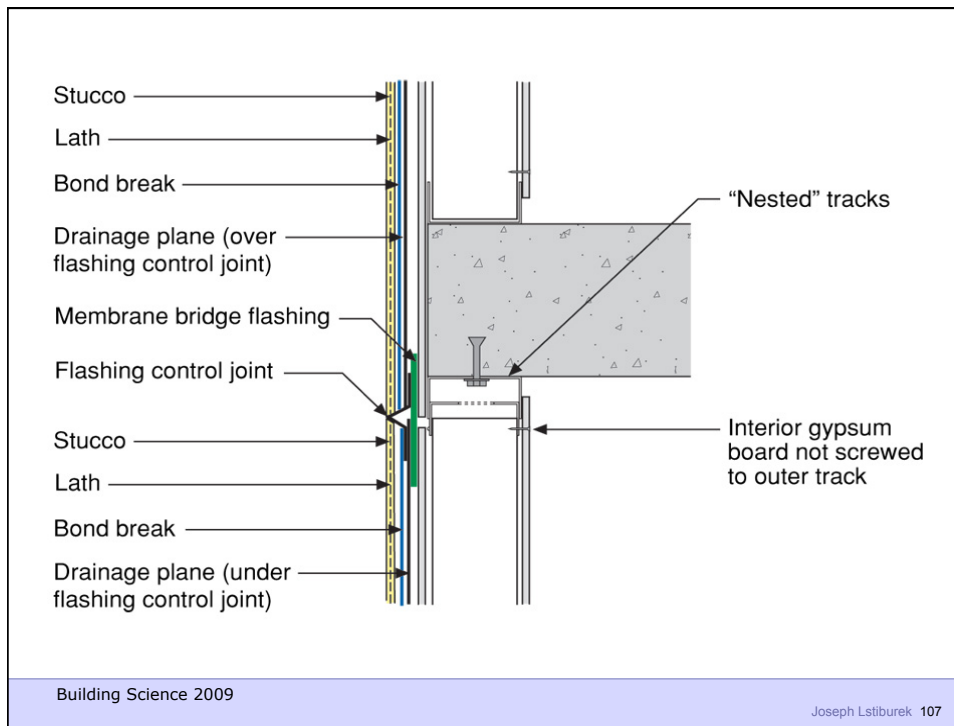

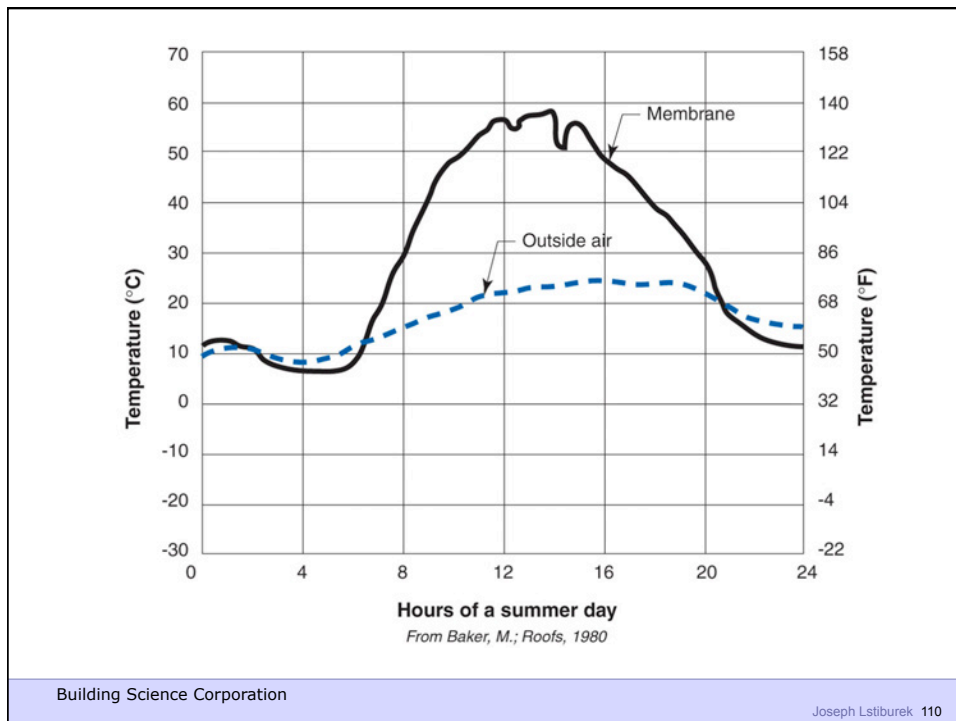
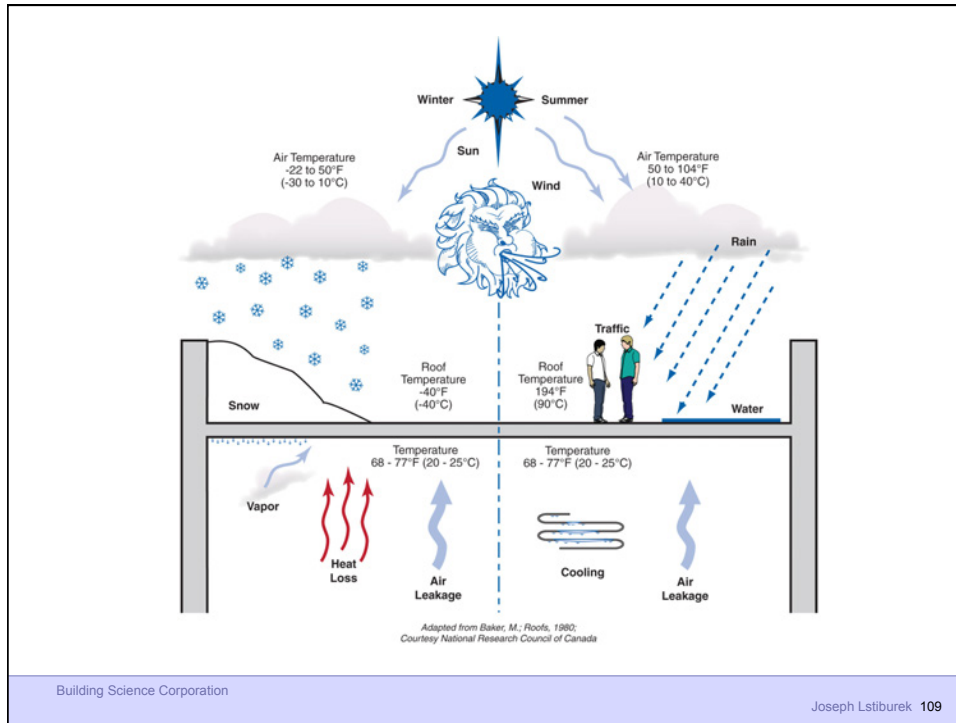

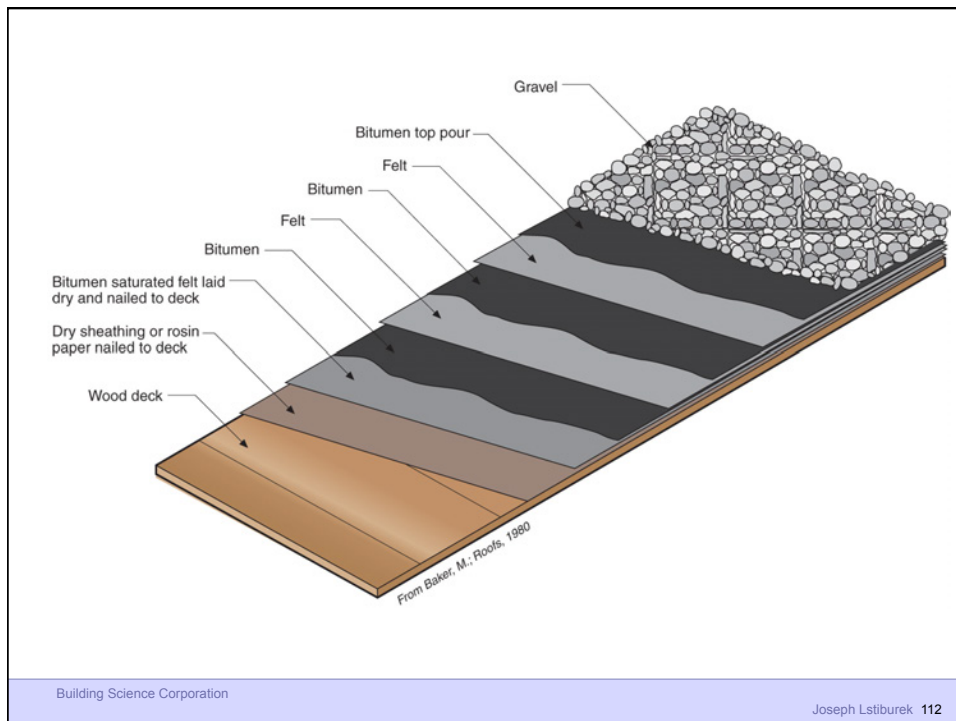
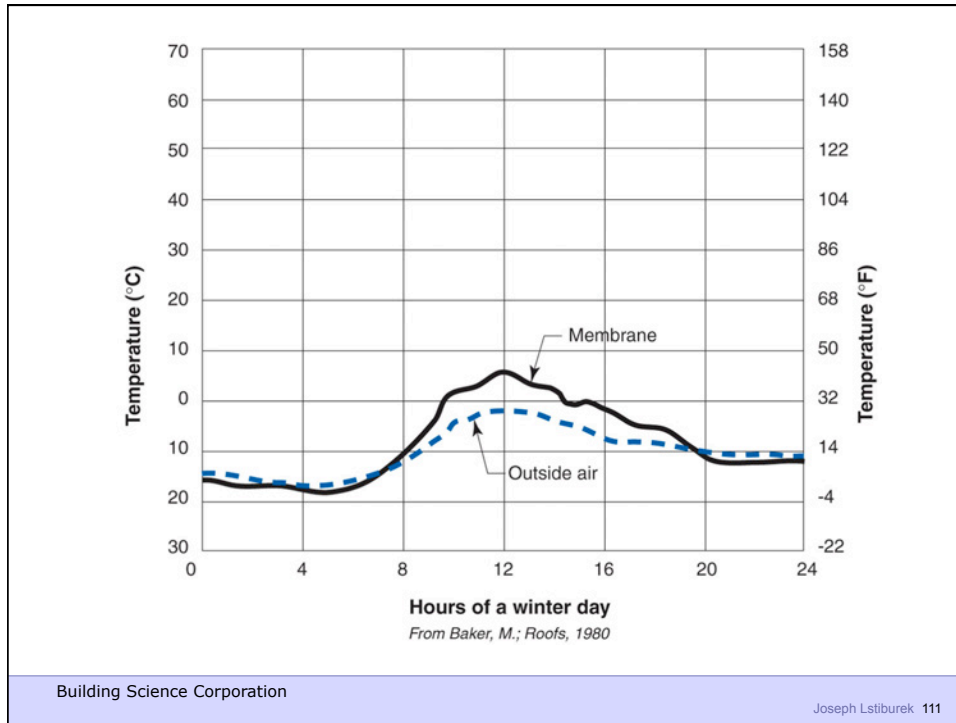

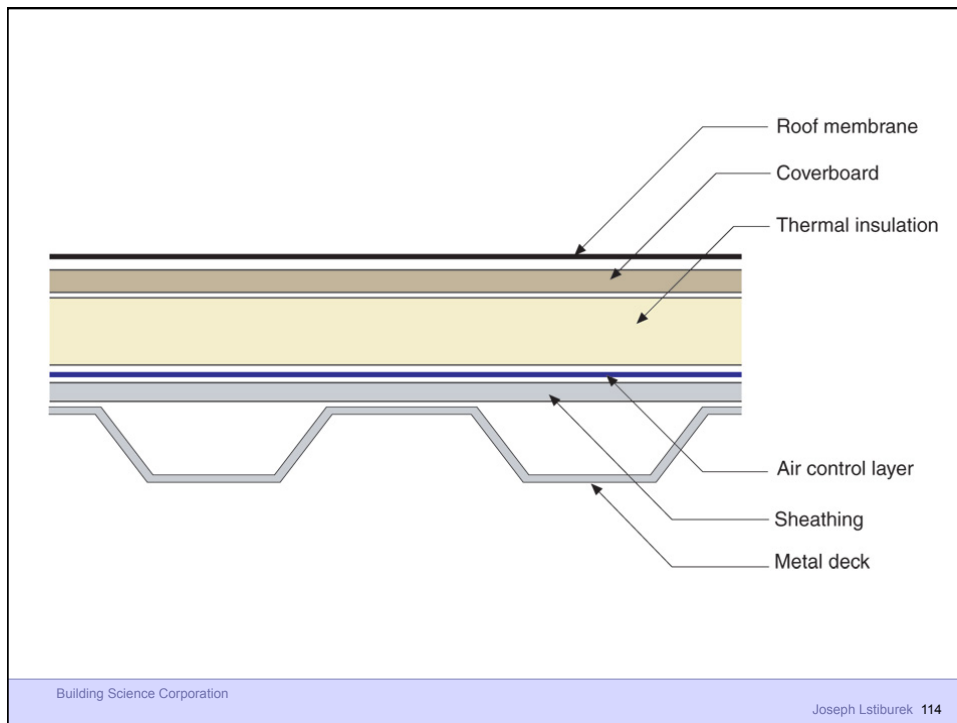
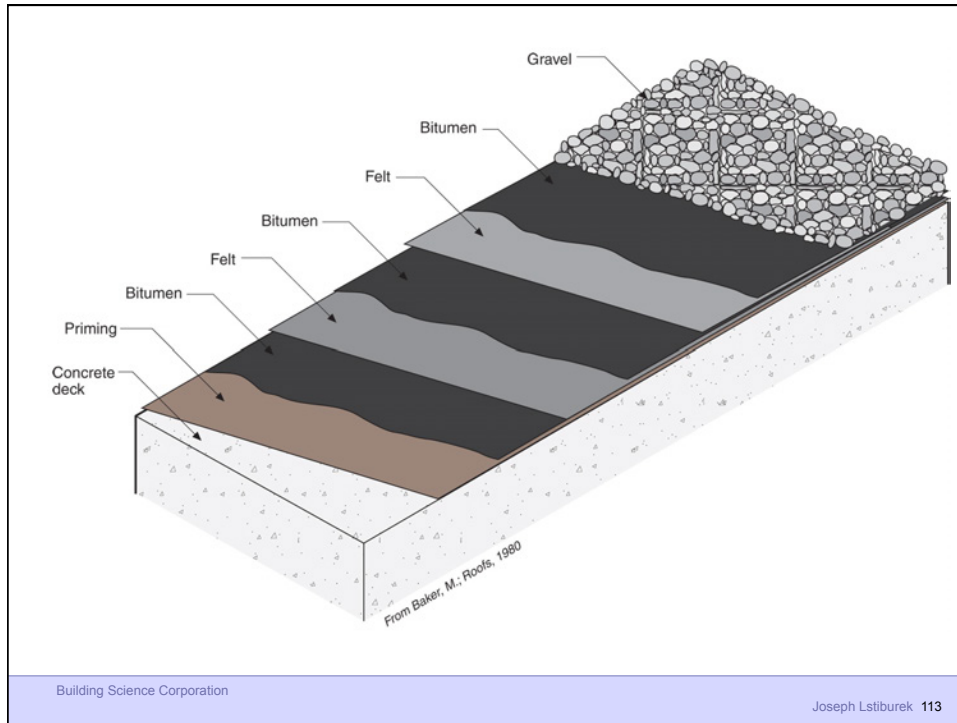

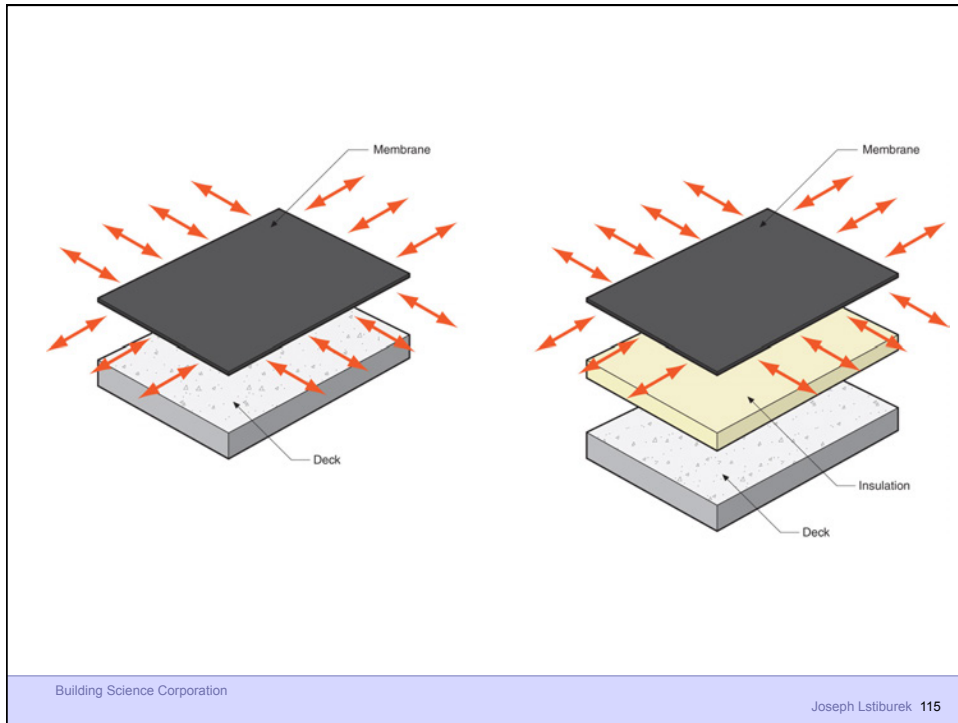

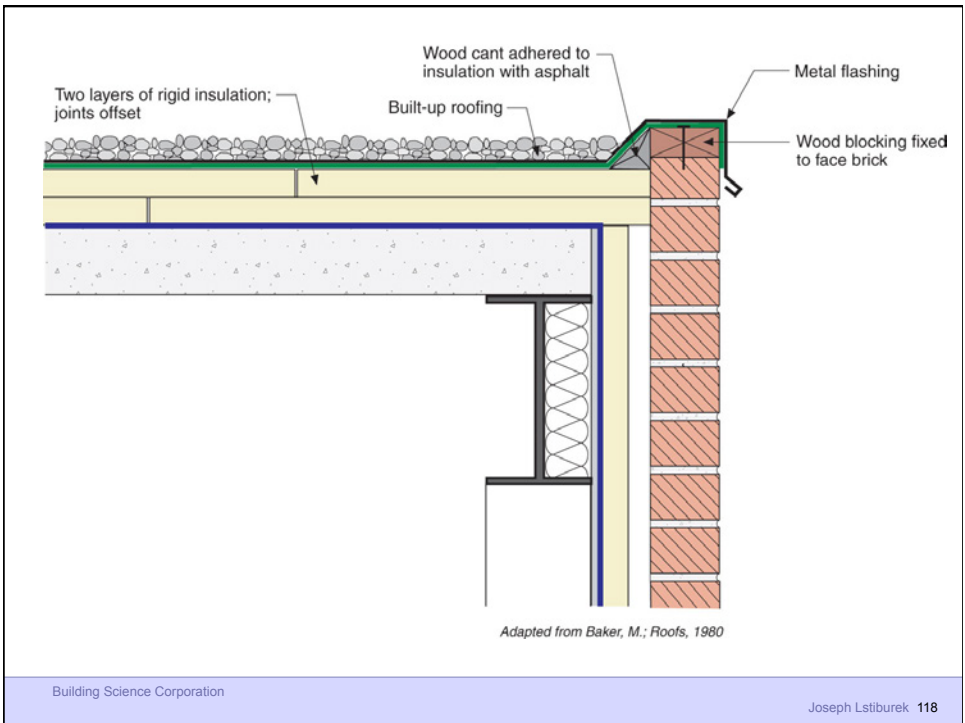
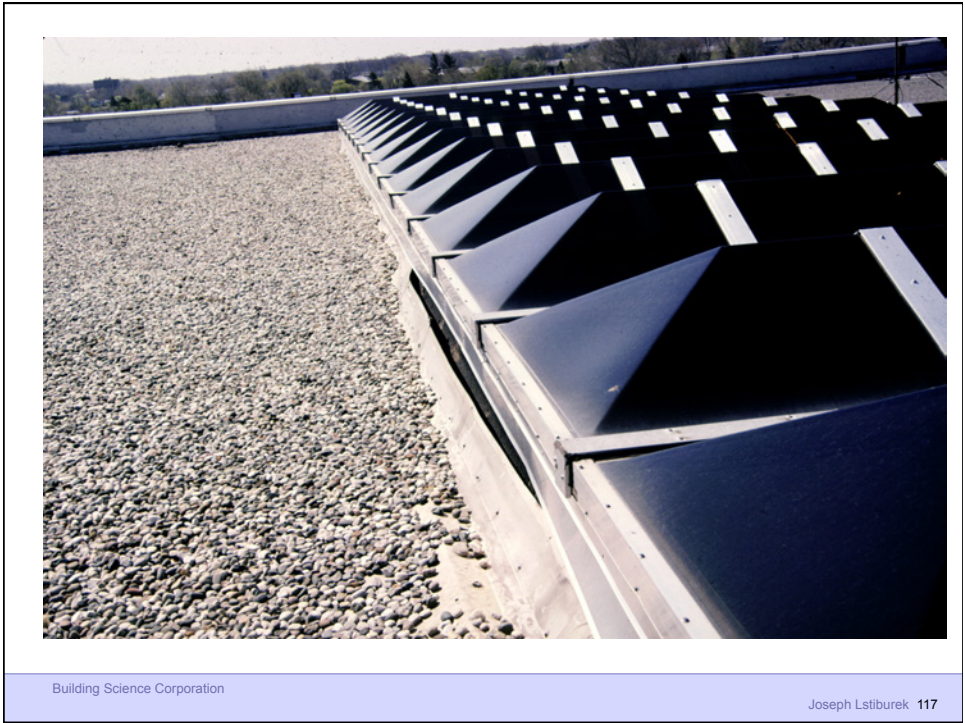

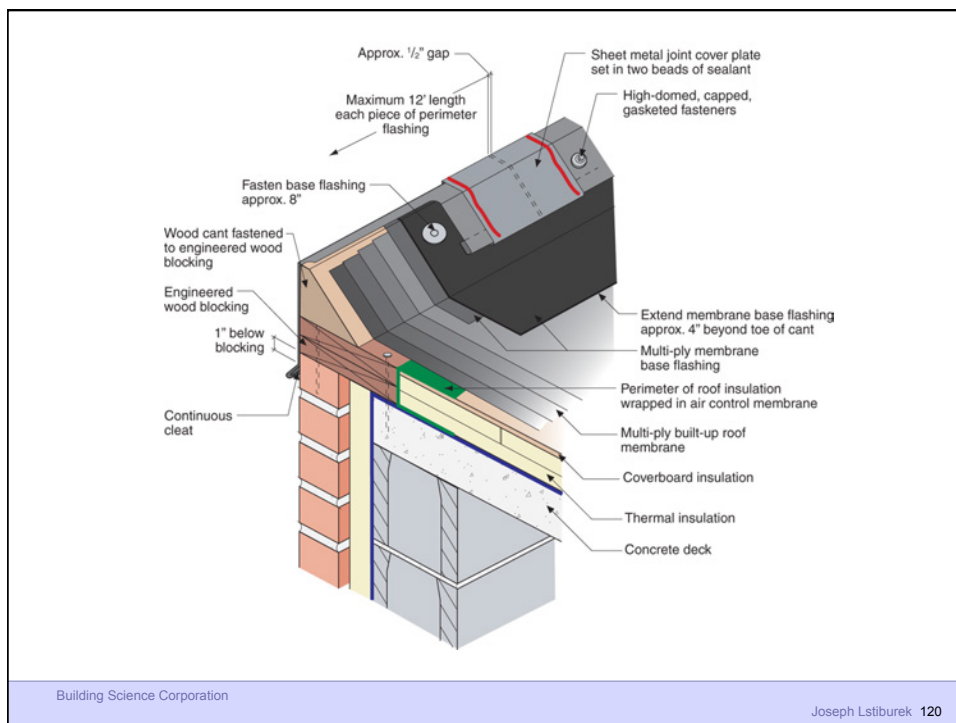
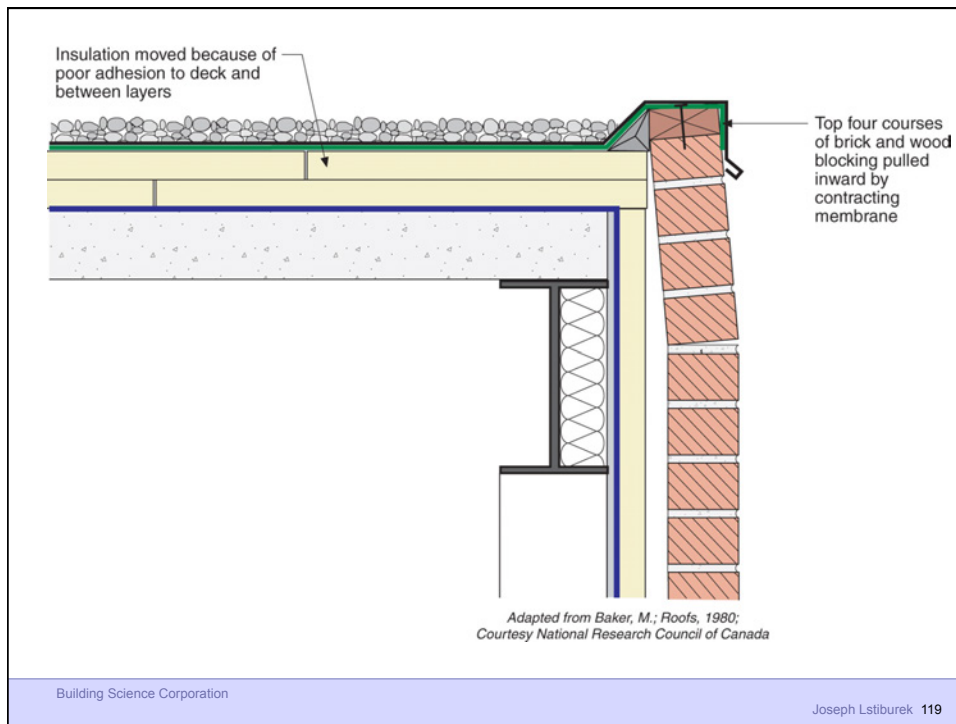

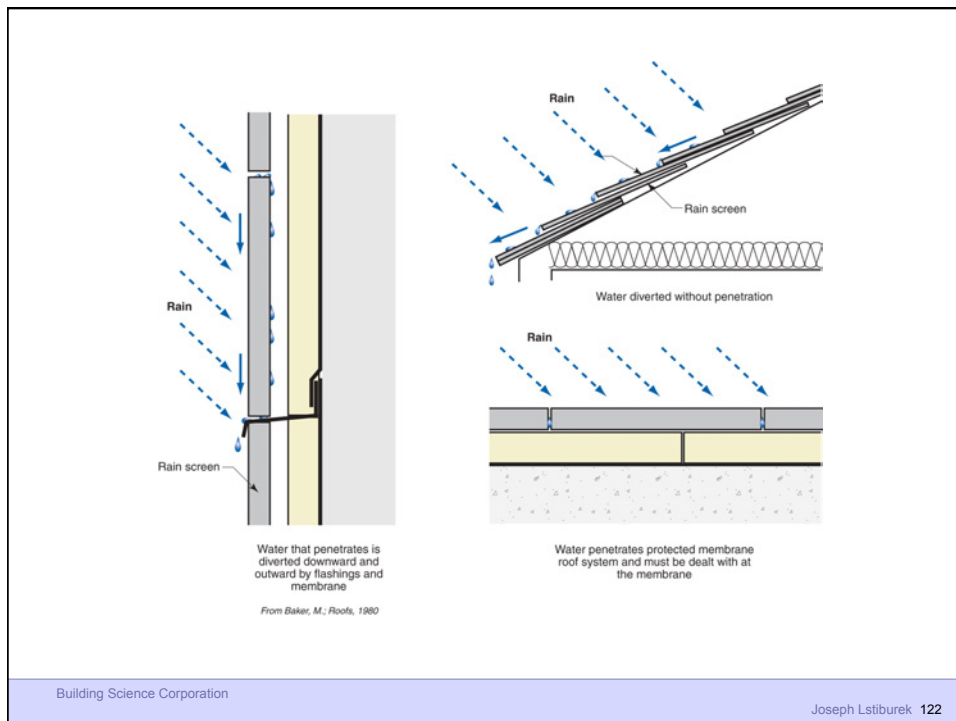
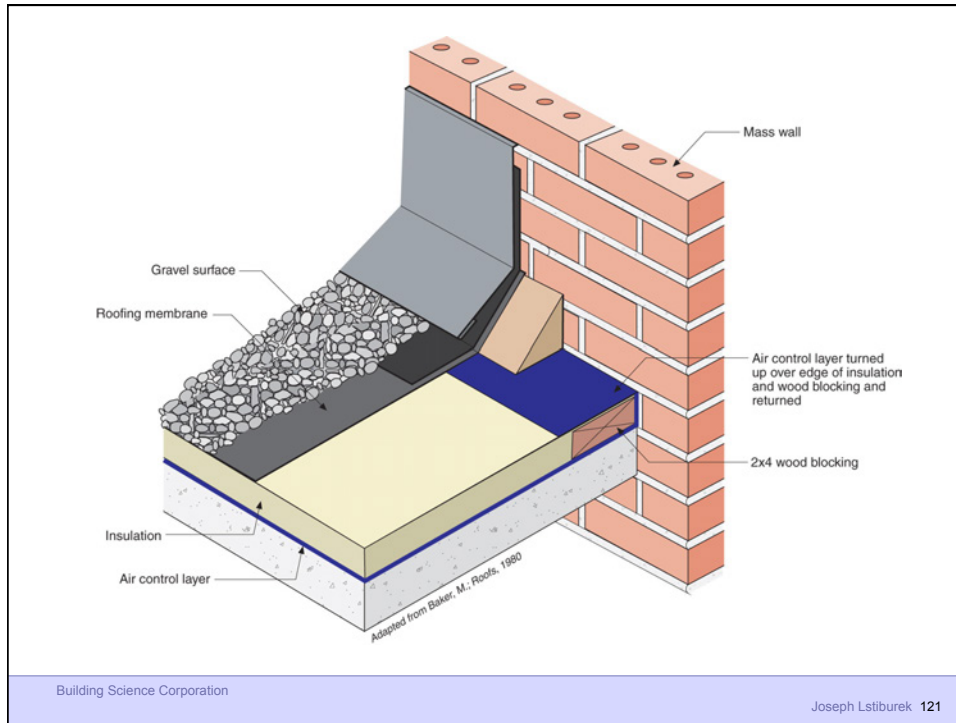

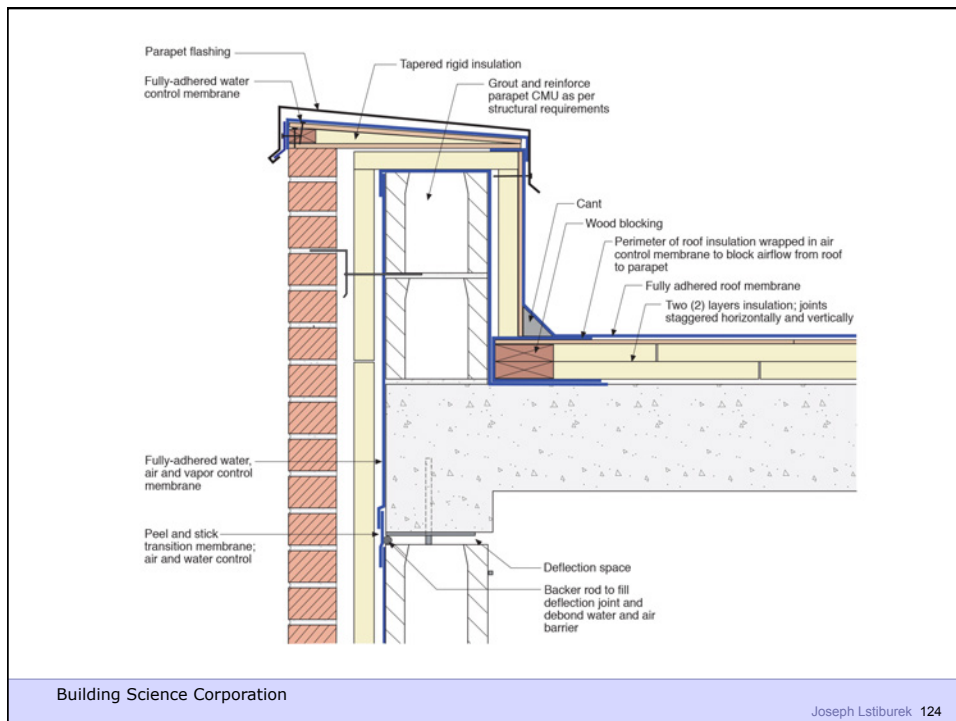
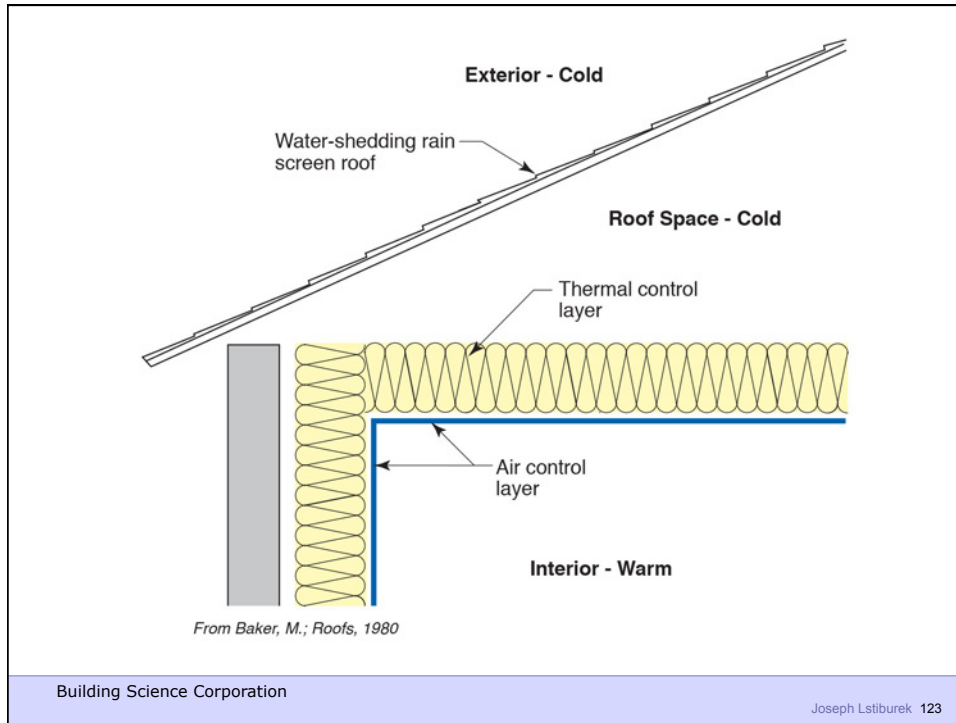

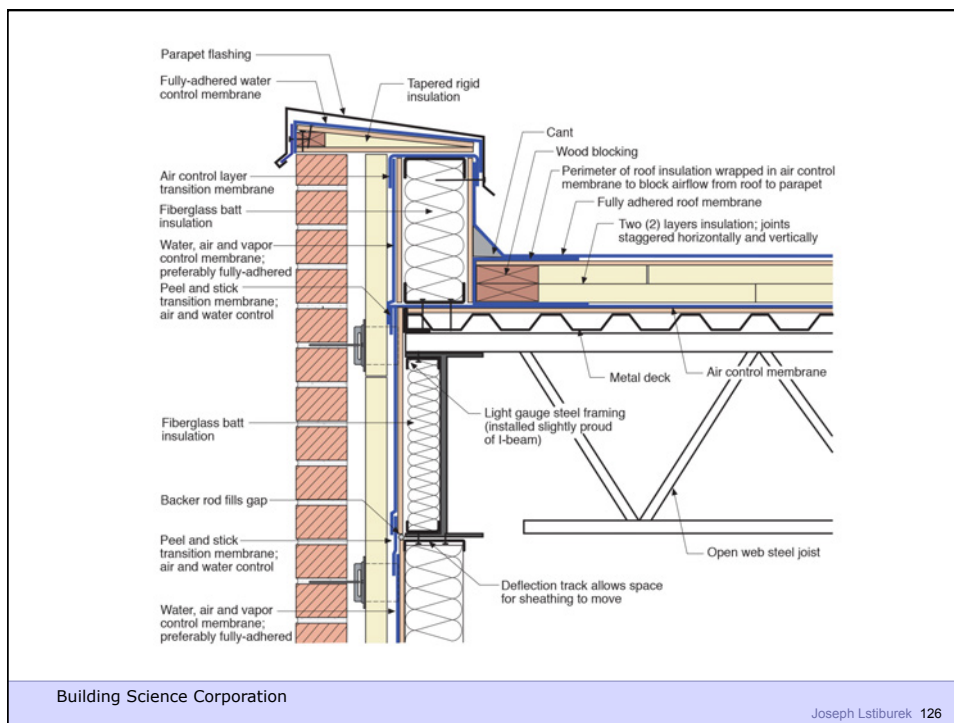
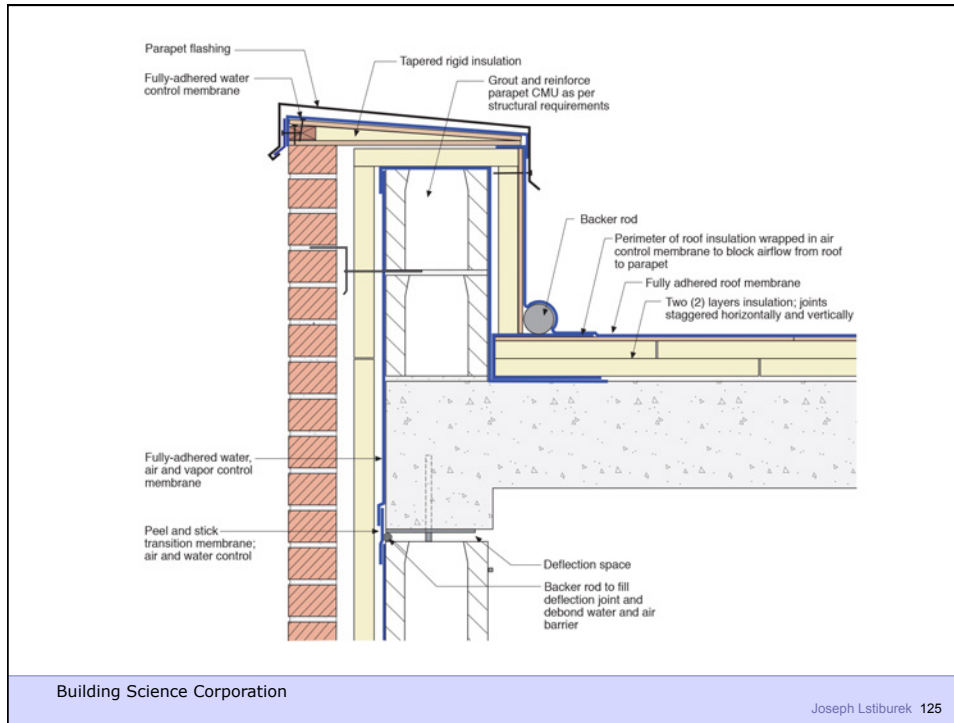

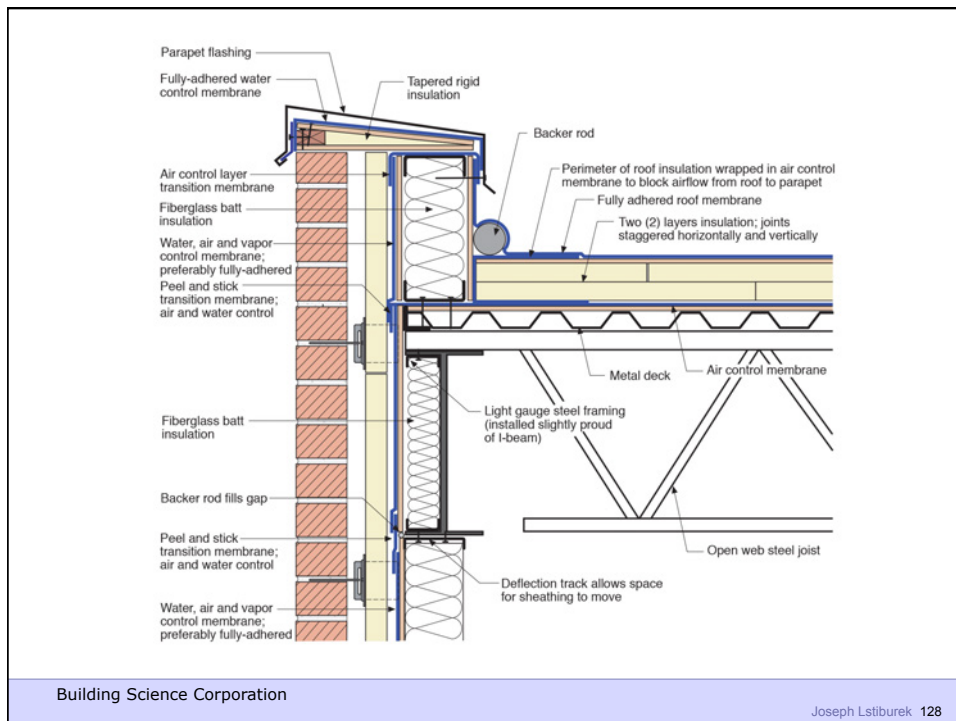
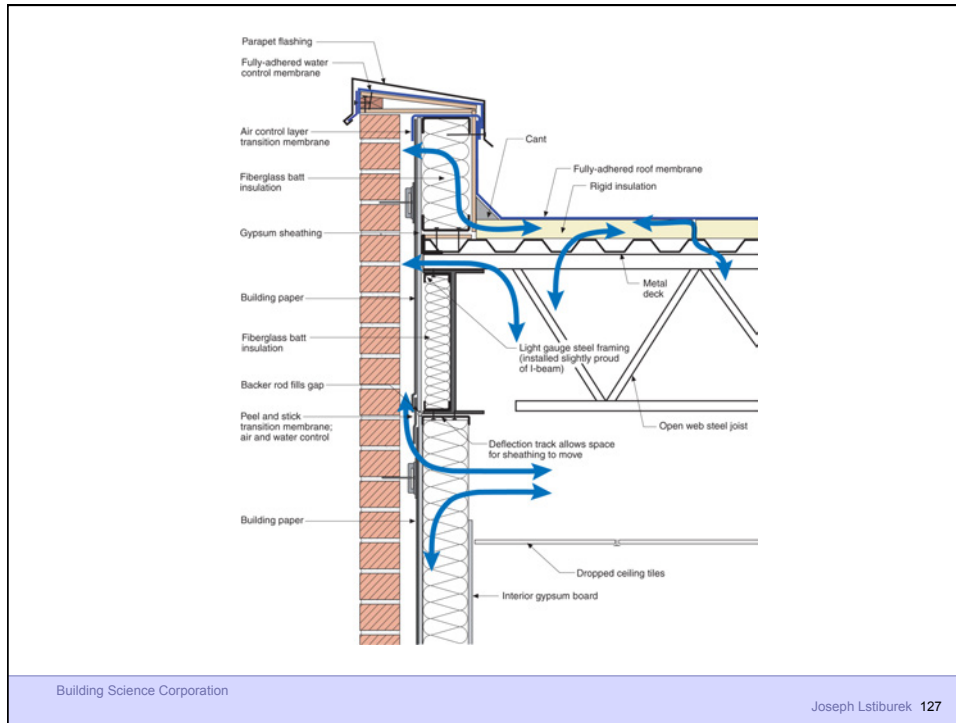

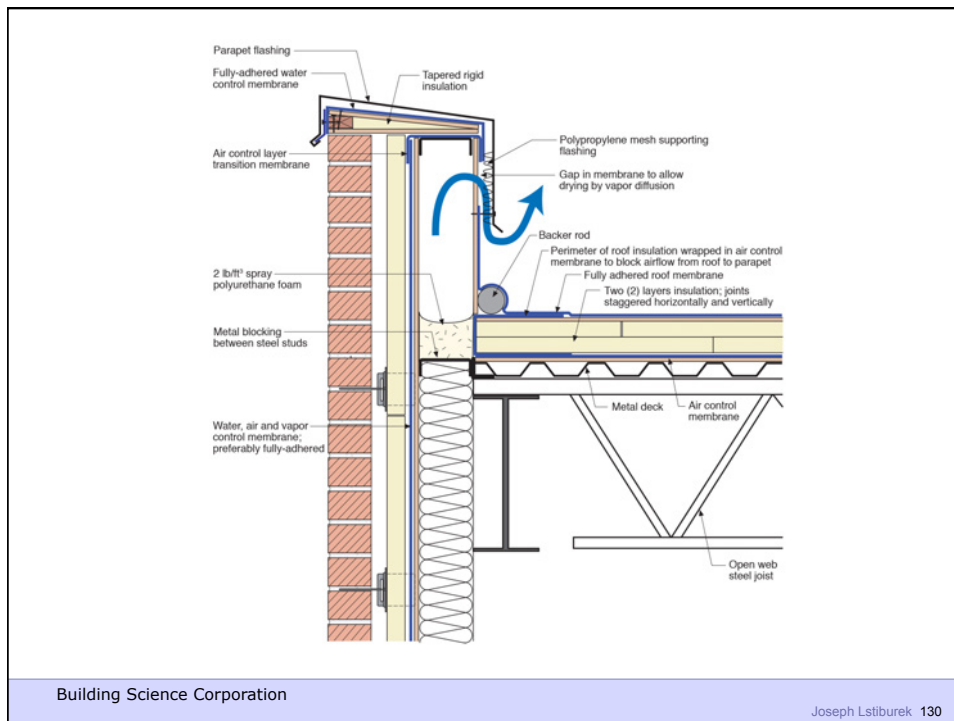
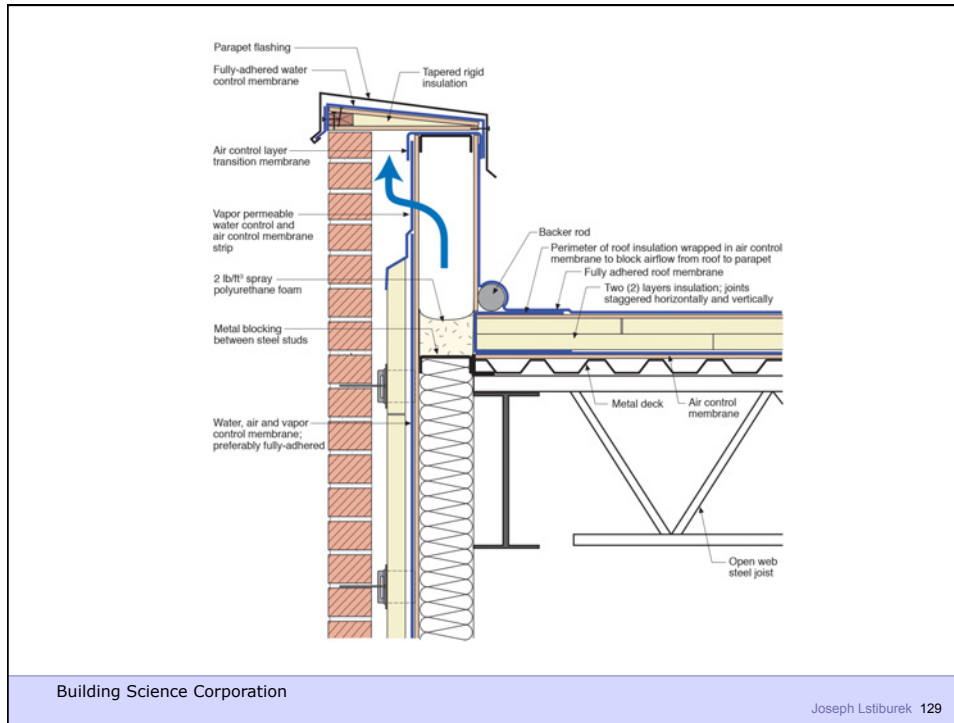

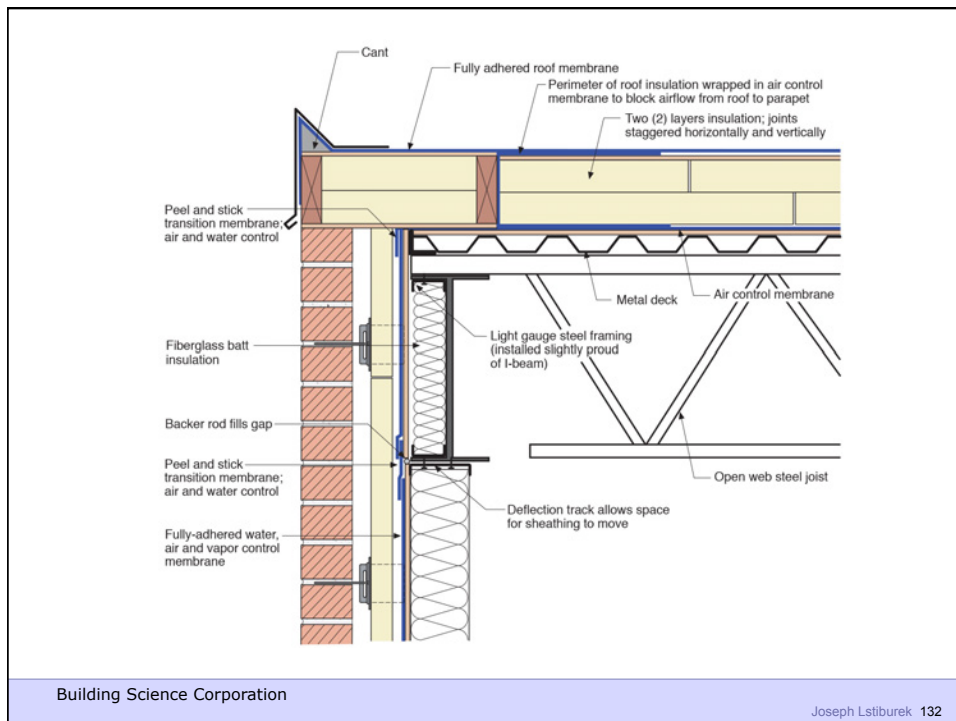
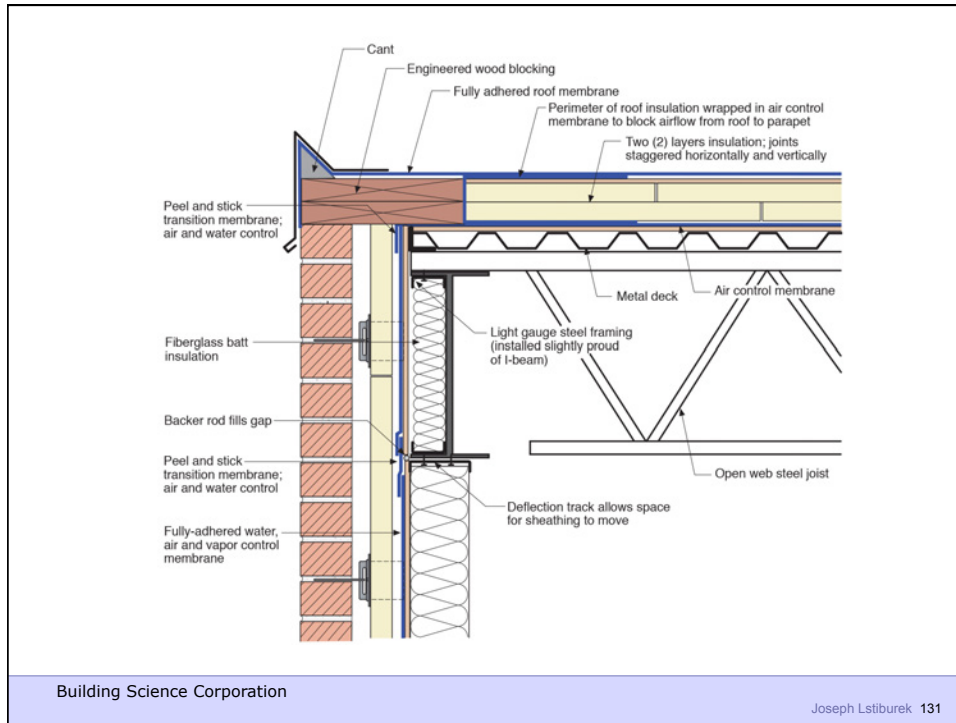

It's a Case of Black or White

Building Science Corporation

Joseph Lstiburek 133

It's a Case of Black or White Arrhenius

Building Science Corporation

Joseph Lstiburek 134

It's a Case of Black or White
 Arrhenius
 Every 10 degrees C – double the “badness”

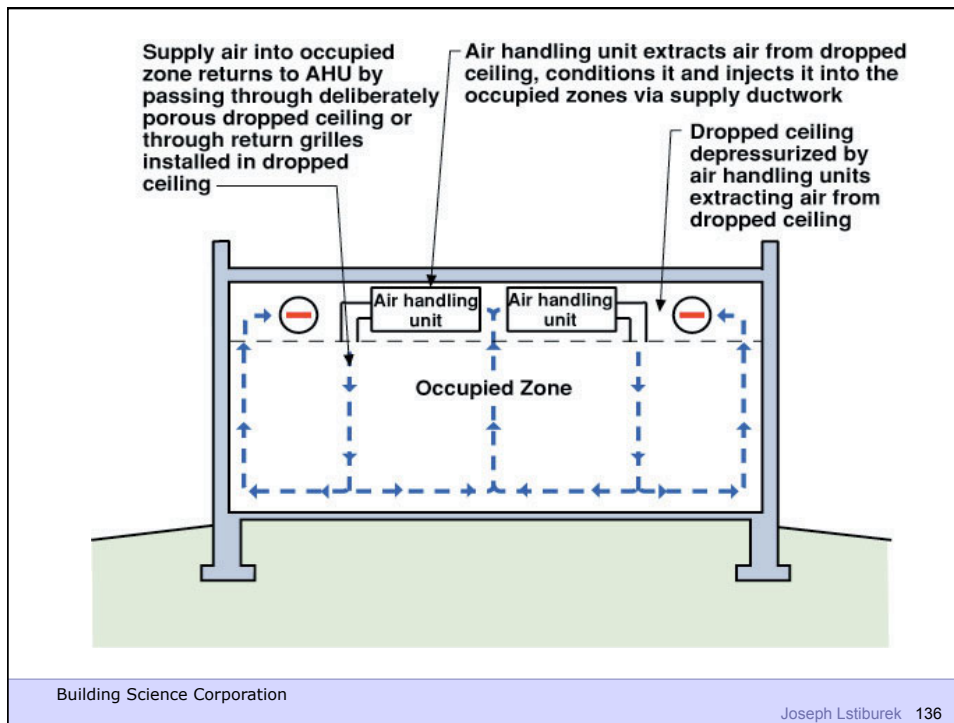

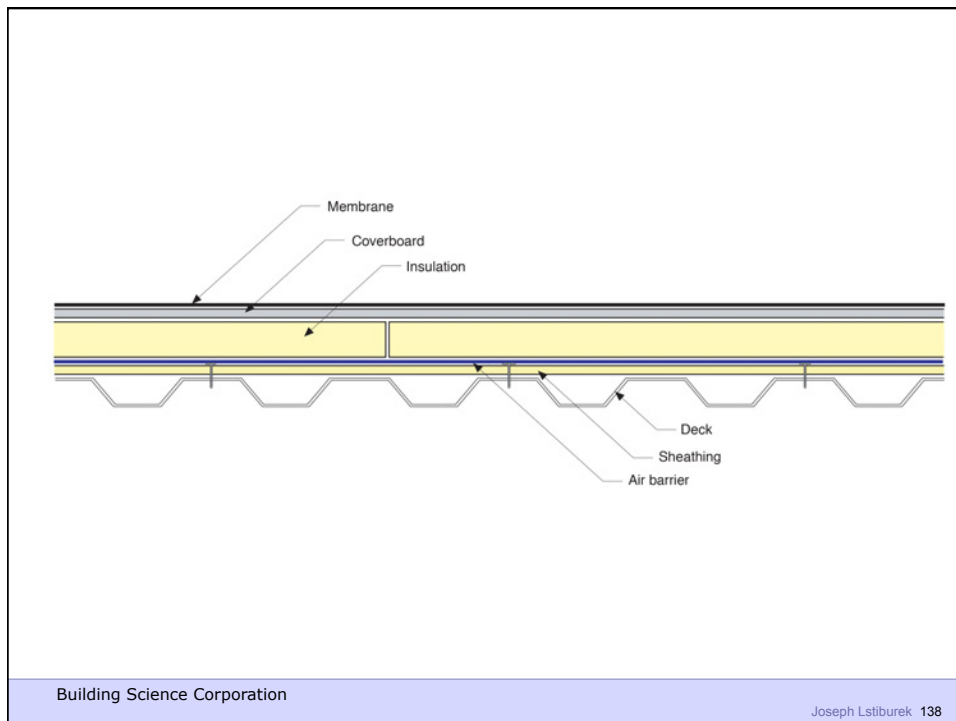
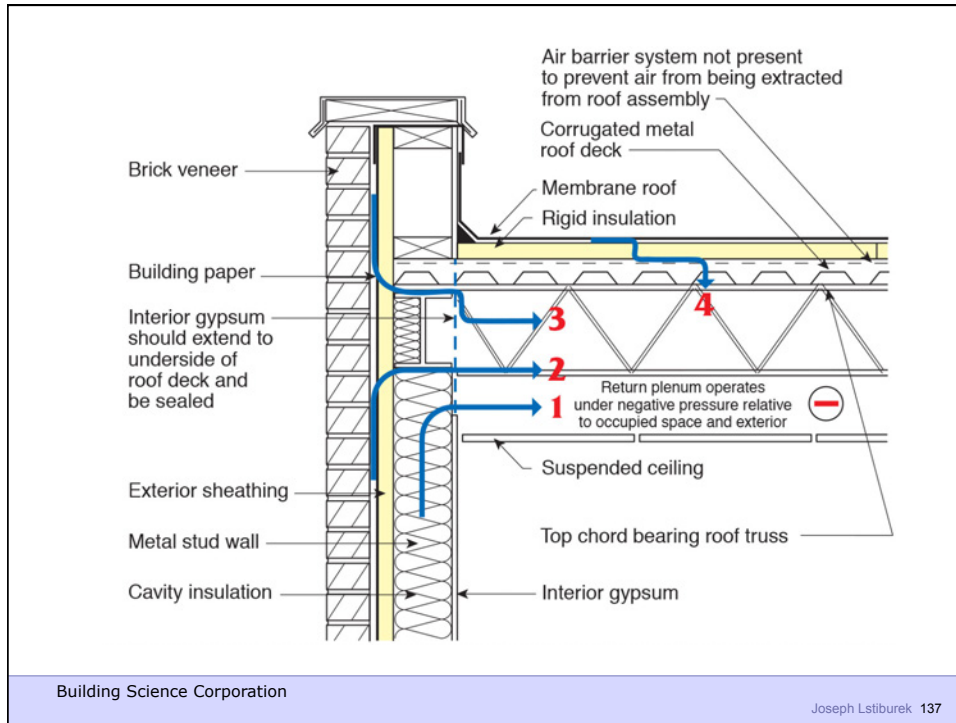

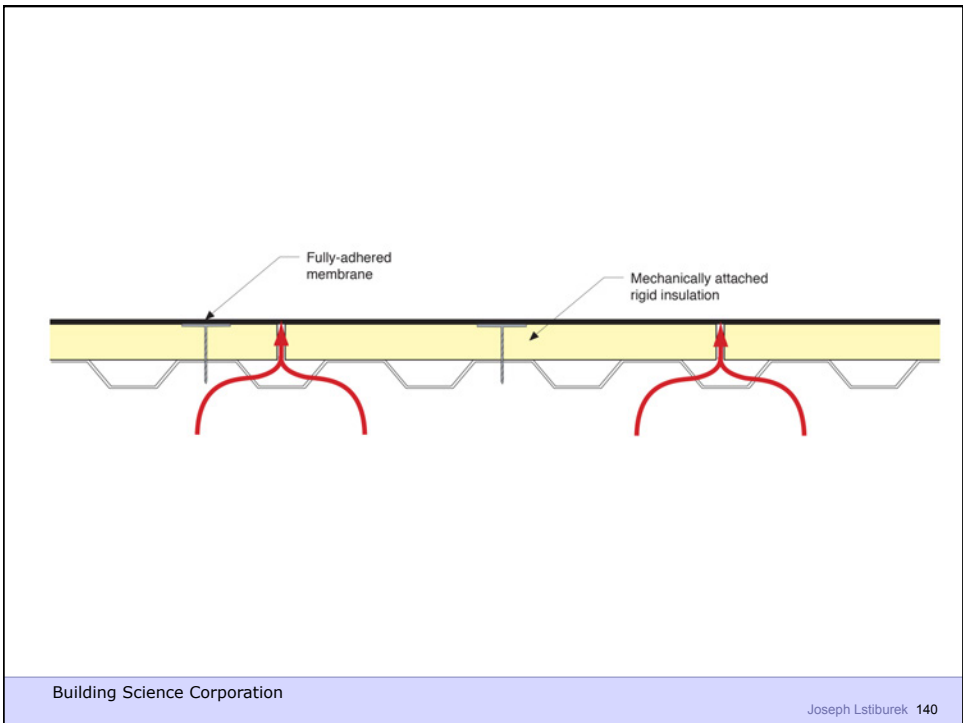
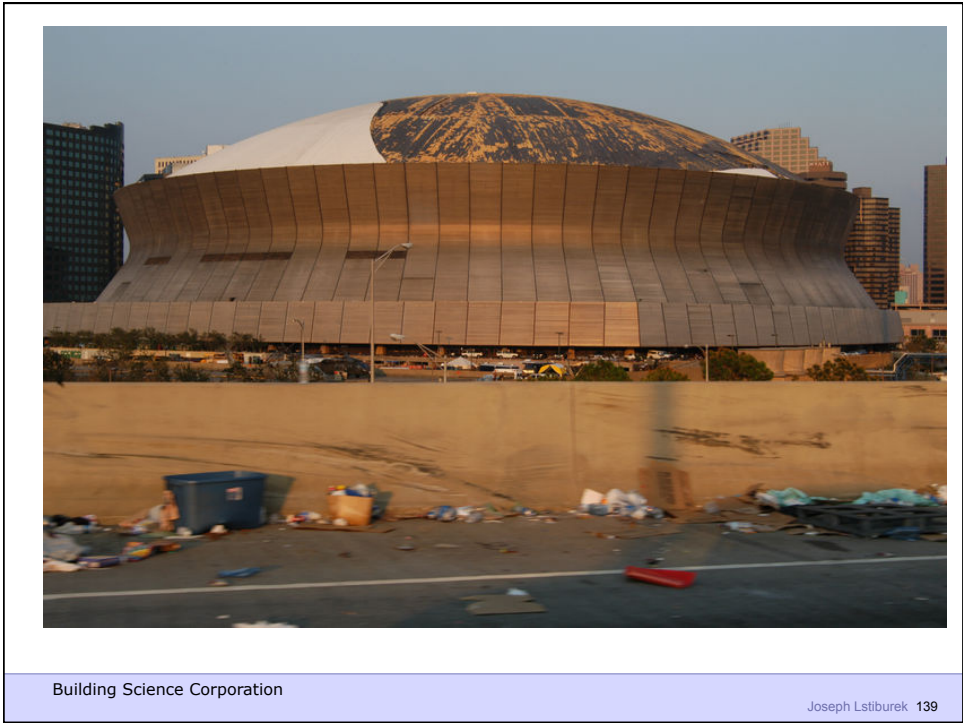

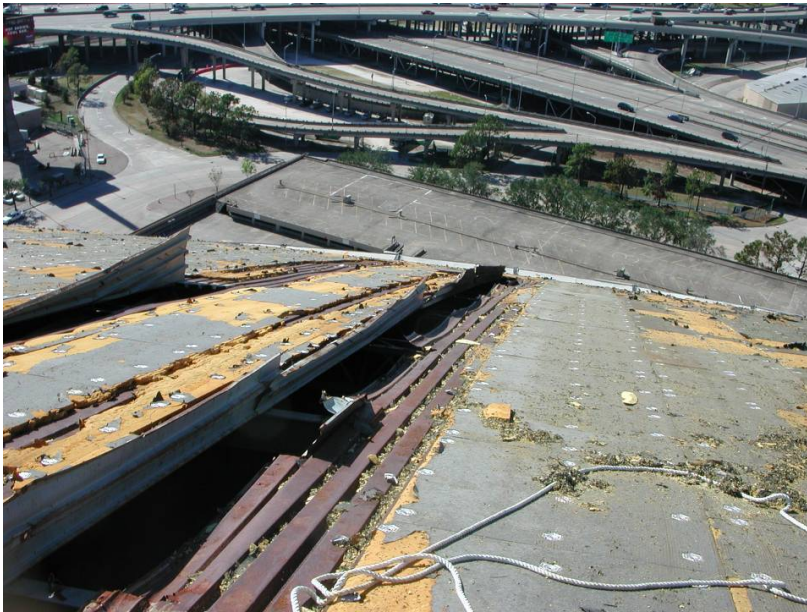

Building Science Corporation

Joseph Lstiburek 141

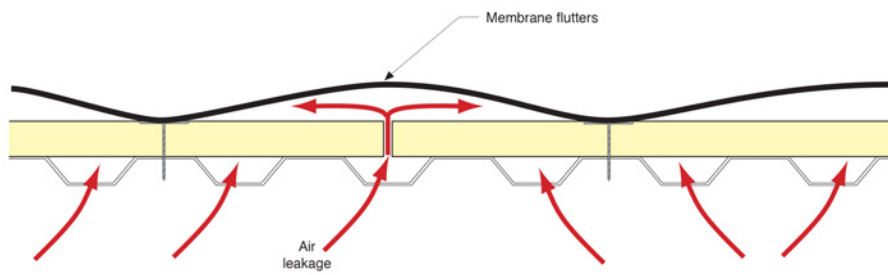

Building Science Corporation

Joseph Lstiburek 142





Building Science Corporation

Joseph Lstiburek 145



Building Science Corporation

Joseph Lstiburek 146

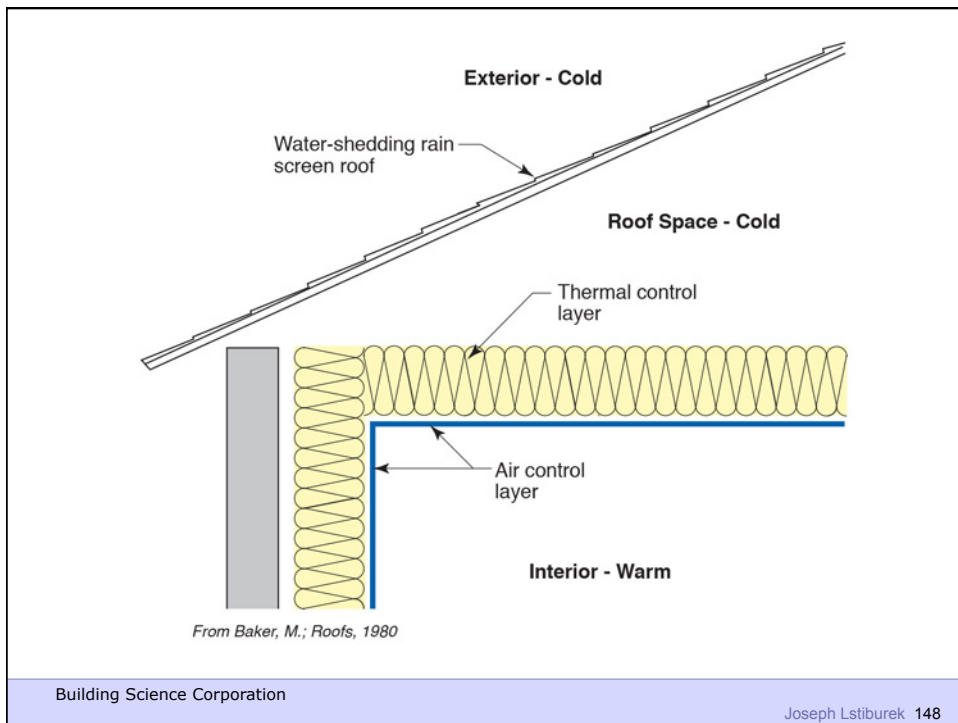
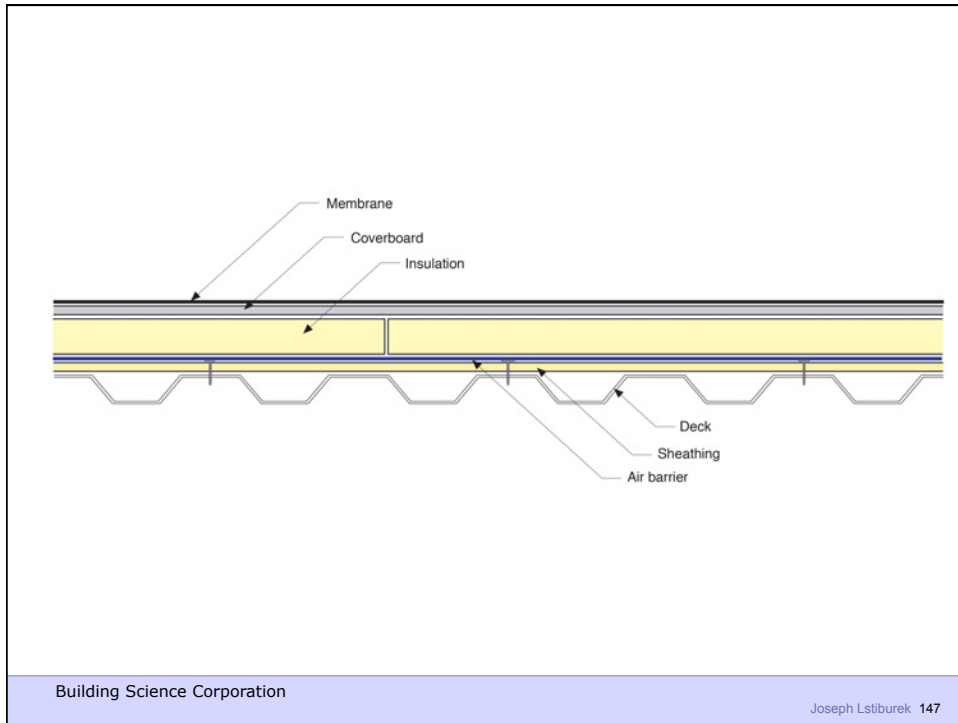

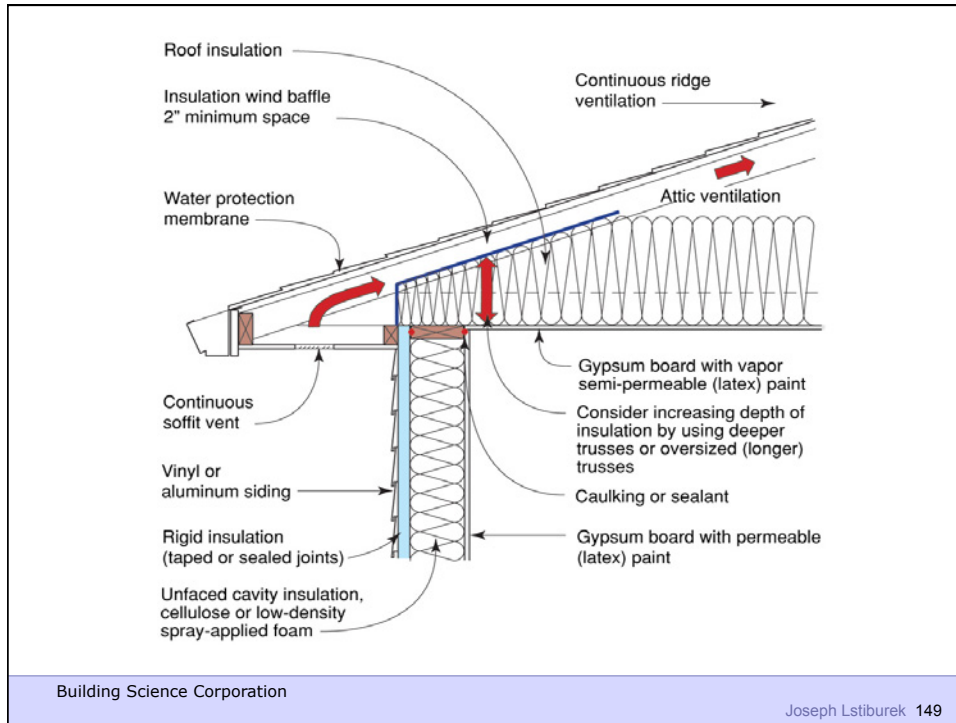

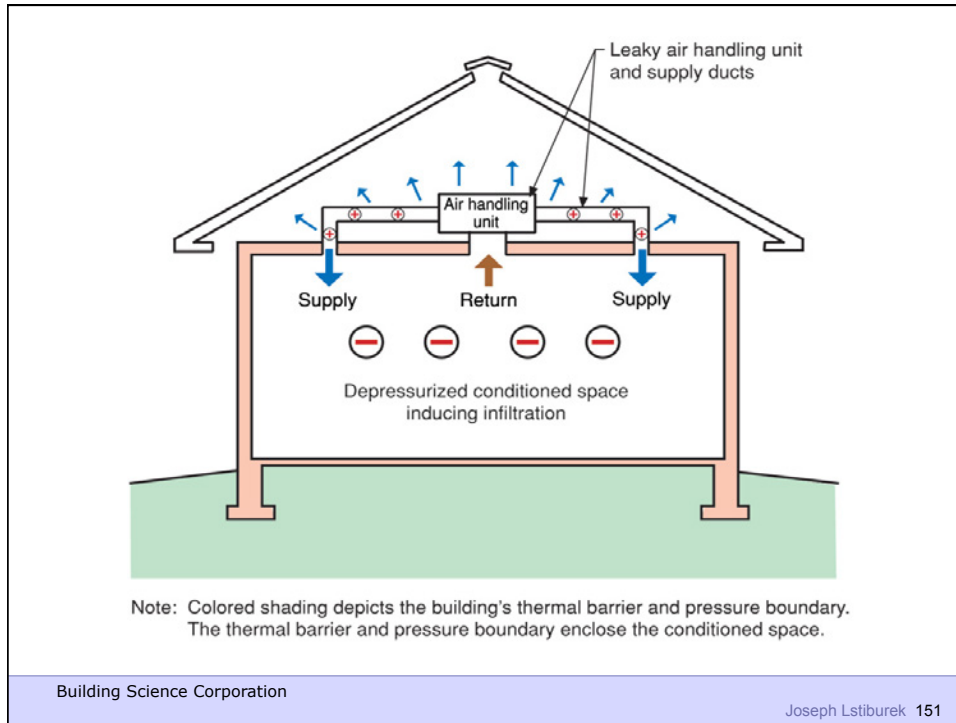

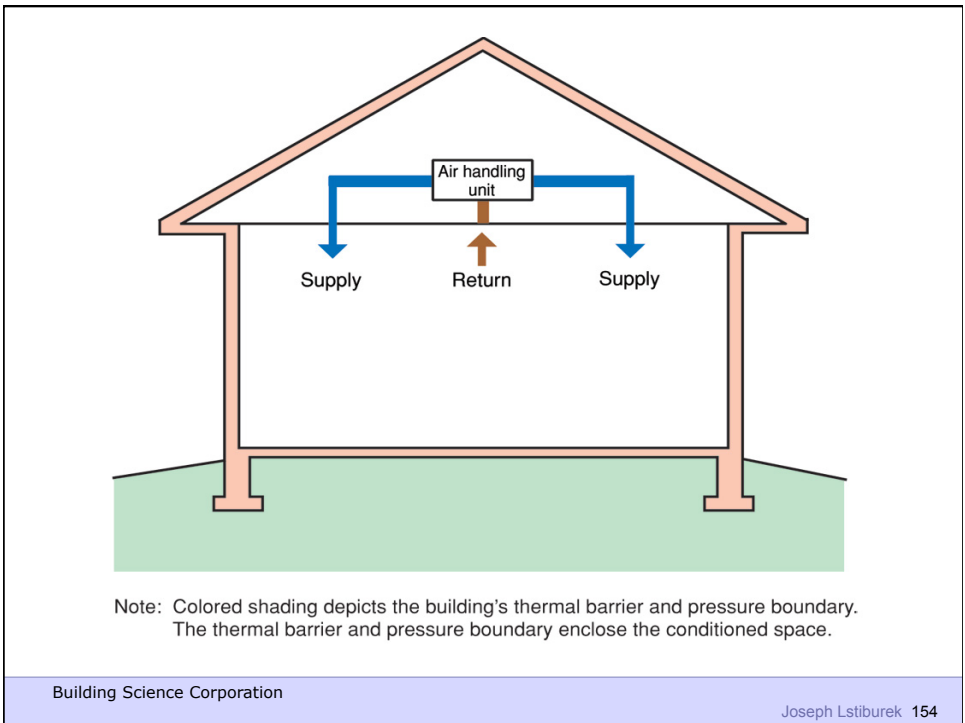
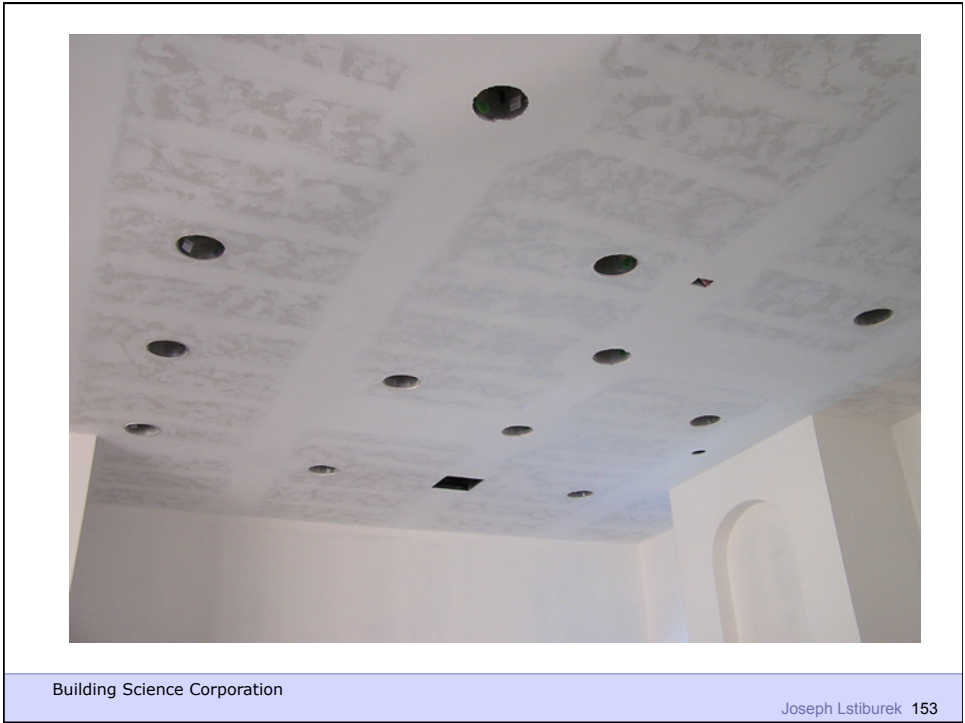

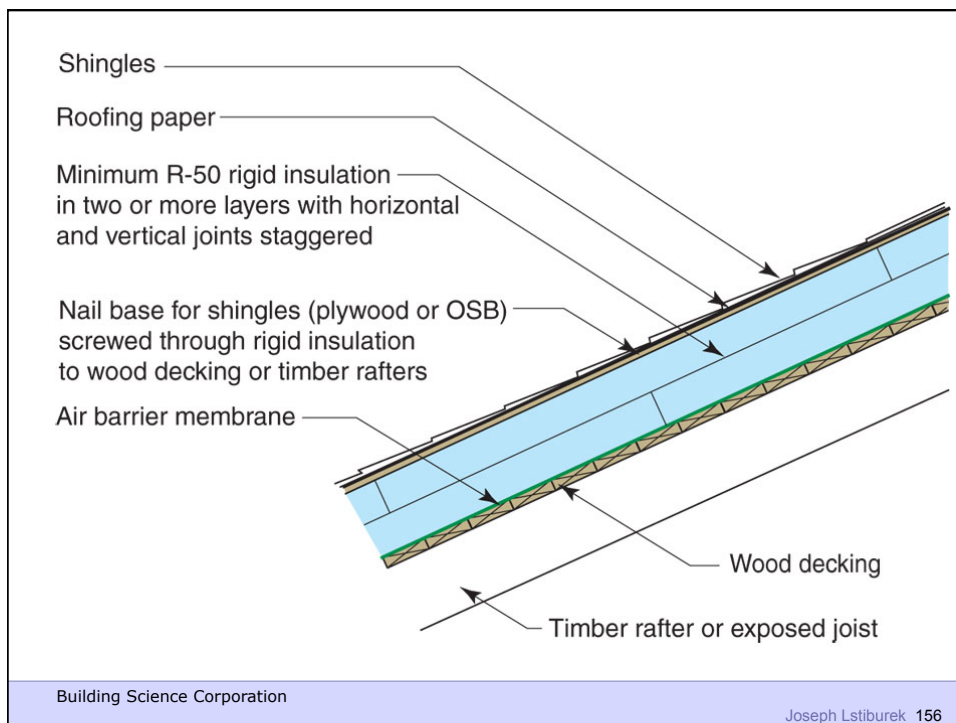
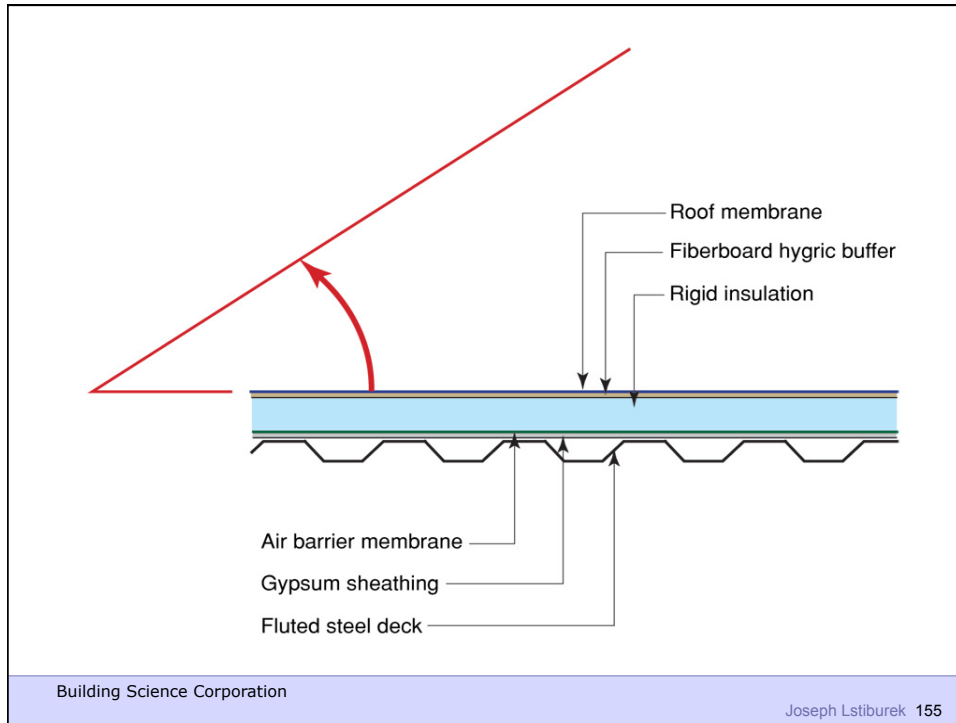

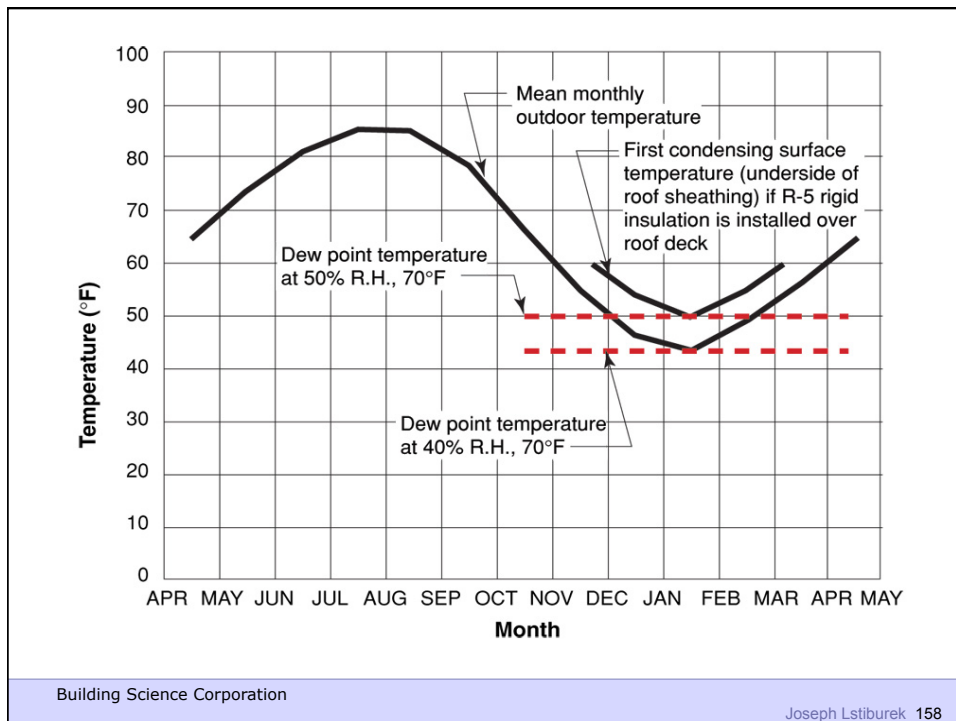
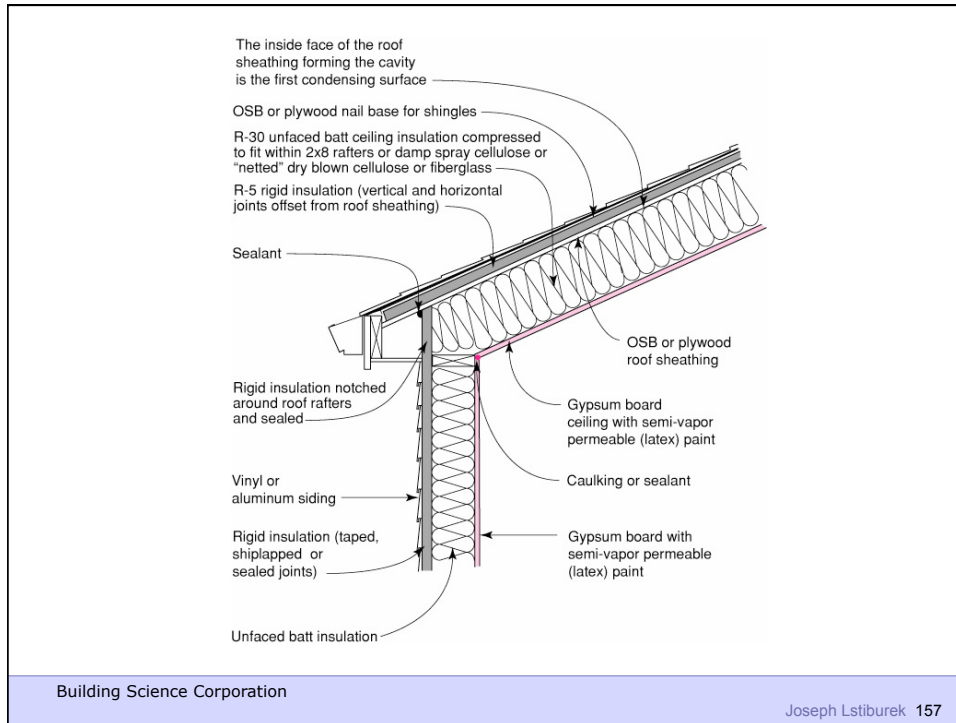

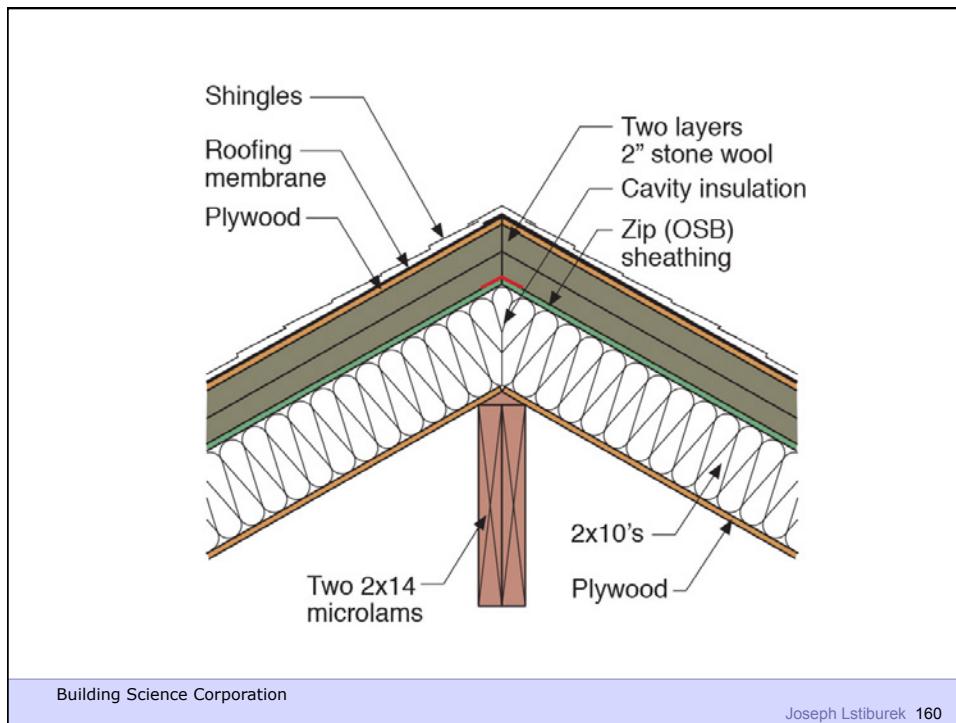
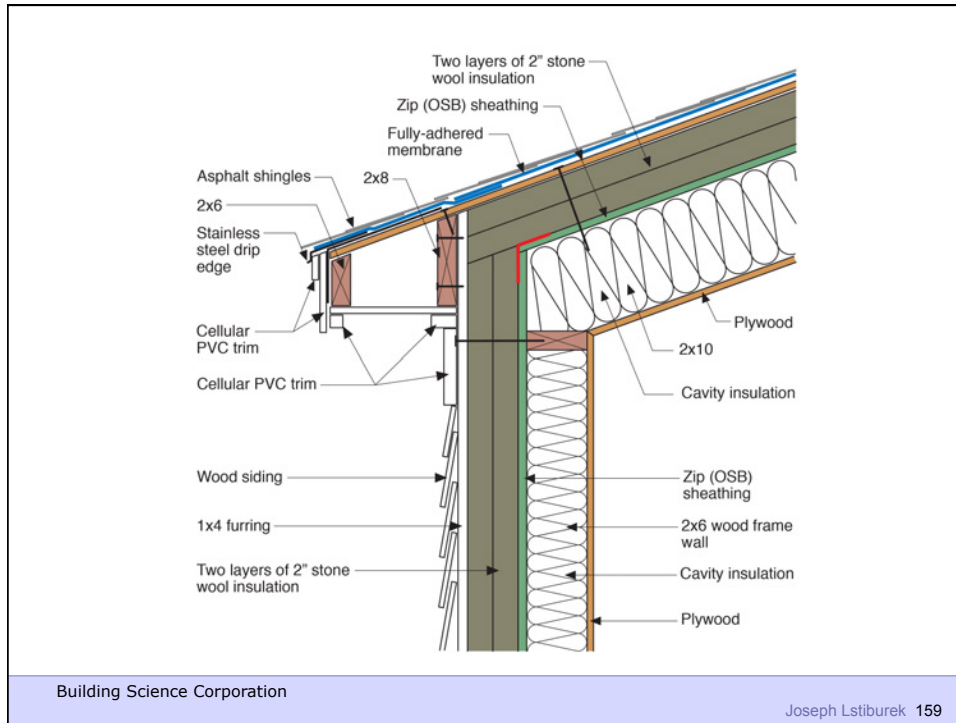





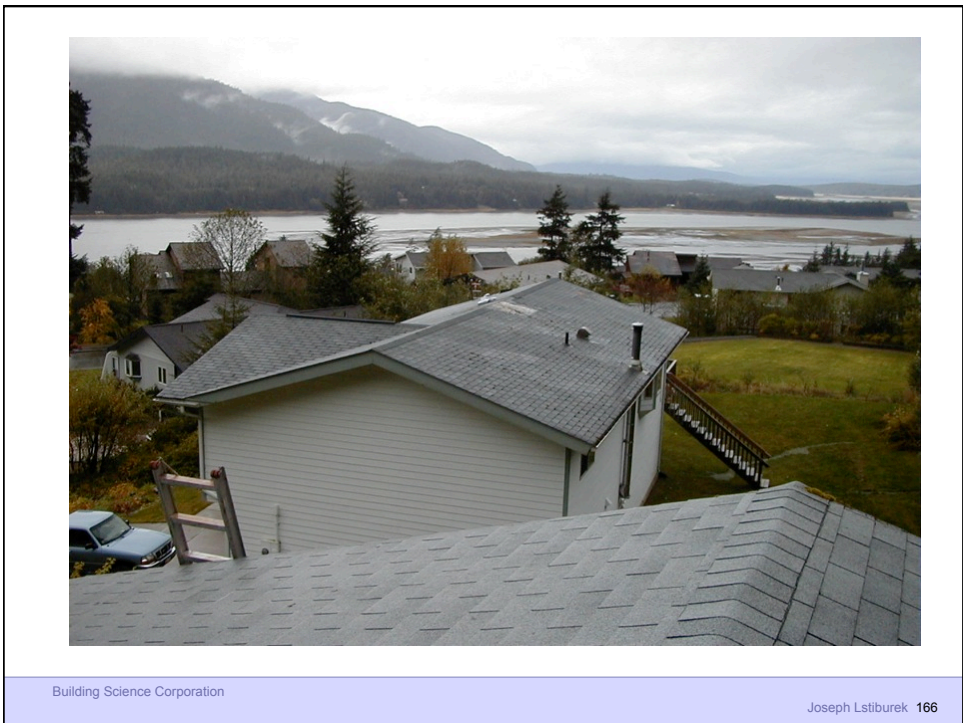

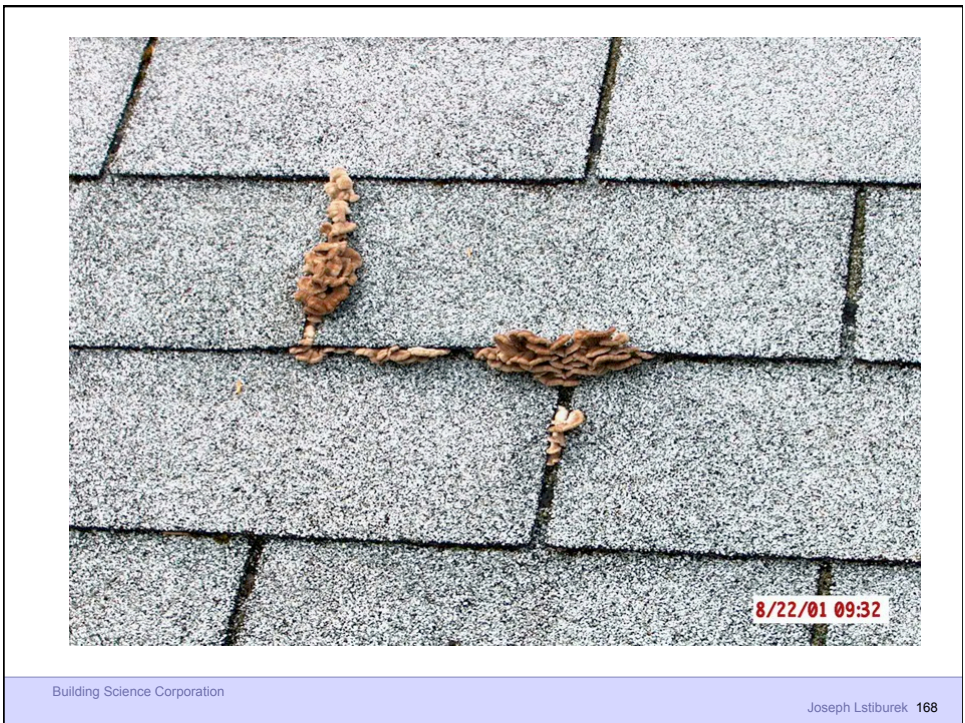
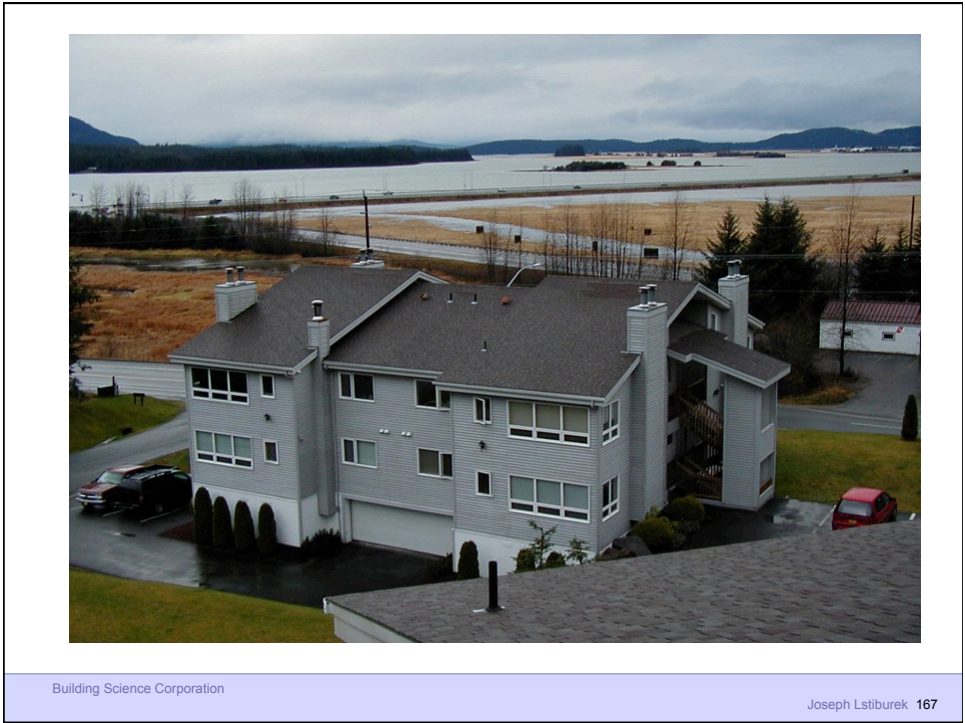



Building Science Corporation

Joseph Lstiburek 169



Building Science Corporation

Joseph Lstiburek 170

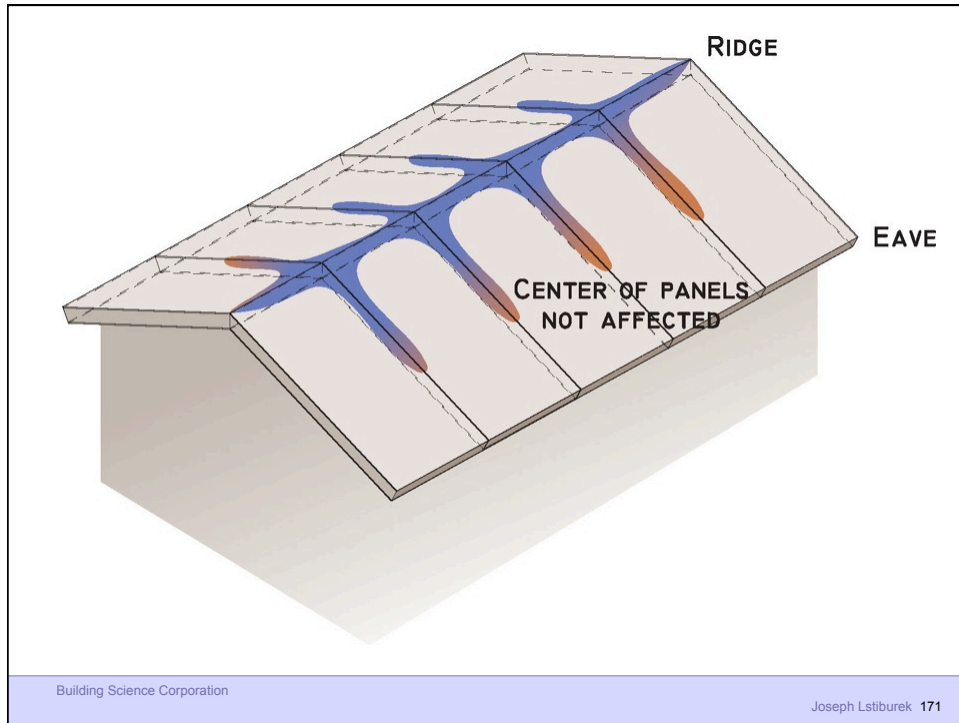



Building Science Corporation

Joseph Lstiburek 173



Building Science Corporation

Joseph Lstiburek 174





Building Science Corporation

Joseph Lstiburek 177



Building Science Corporation

Joseph Lstiburek 178

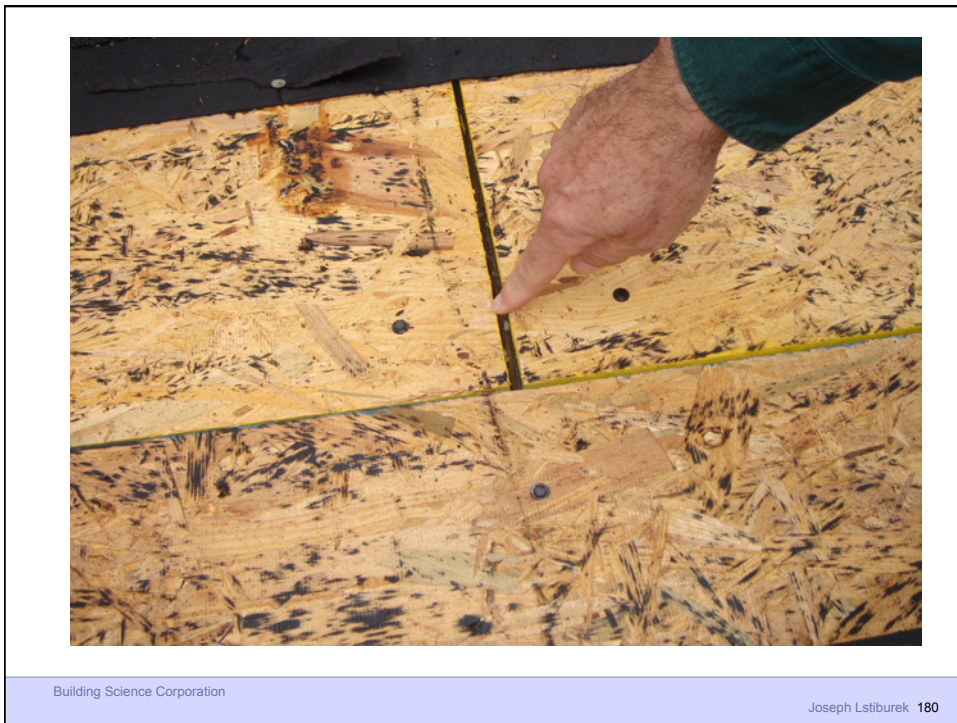

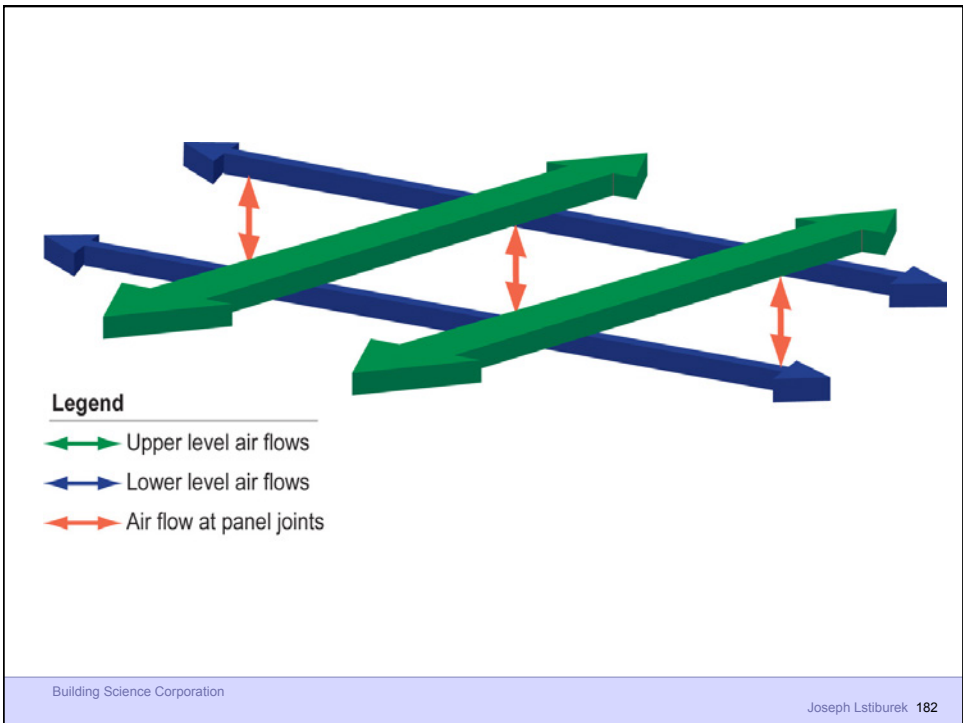

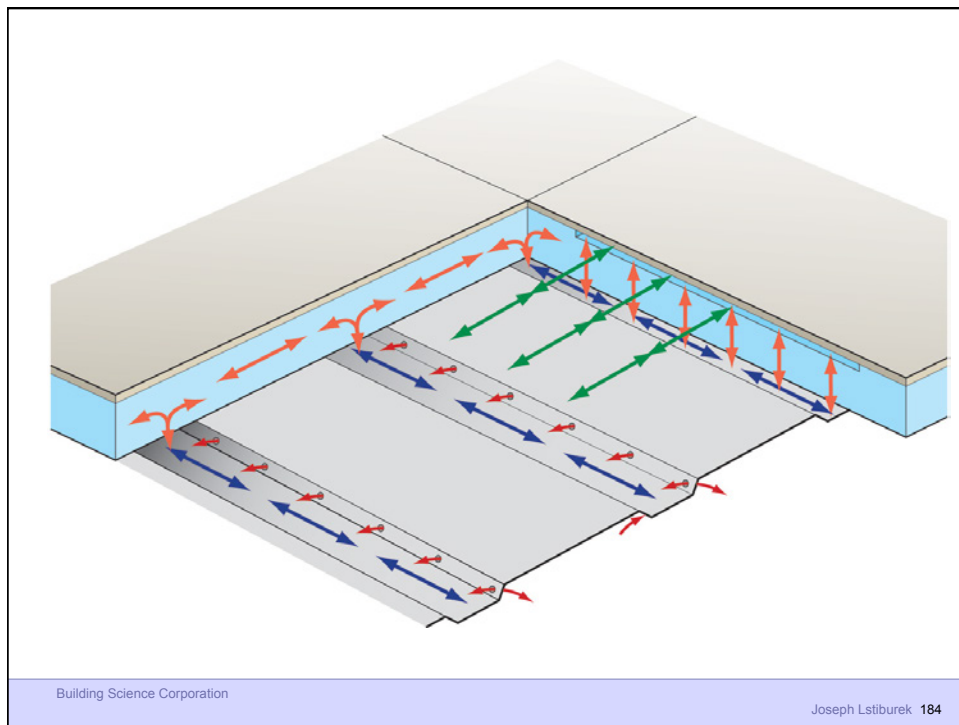
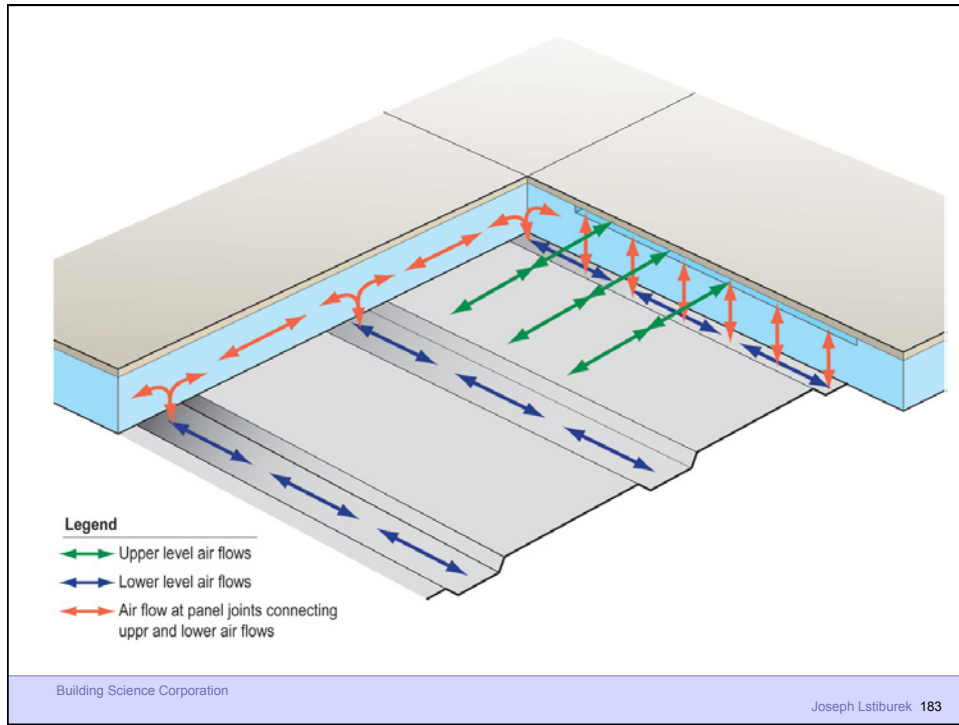

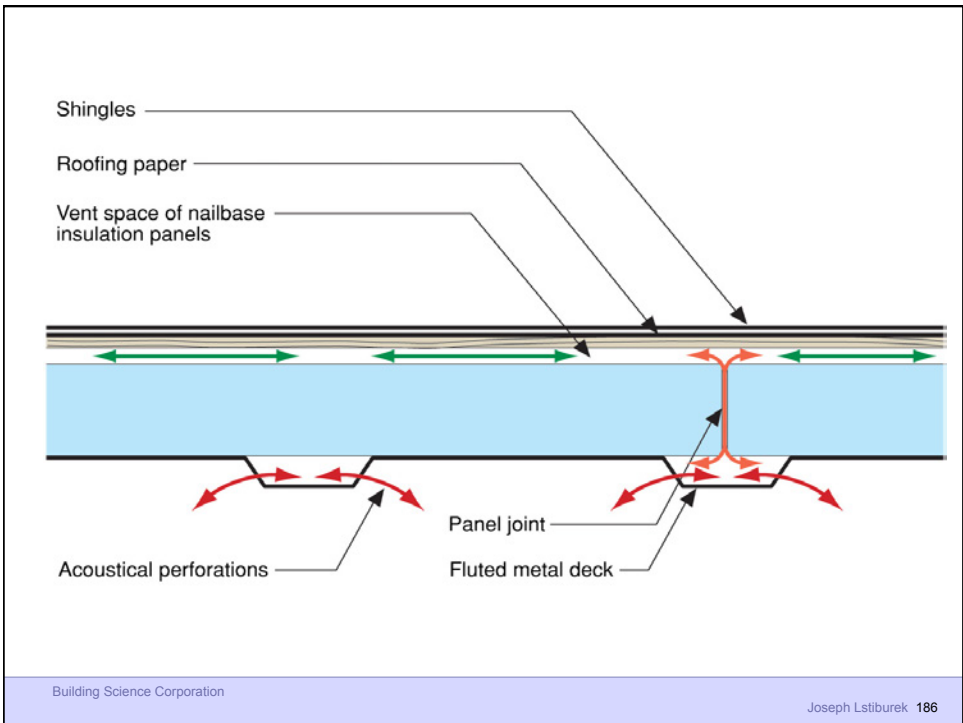

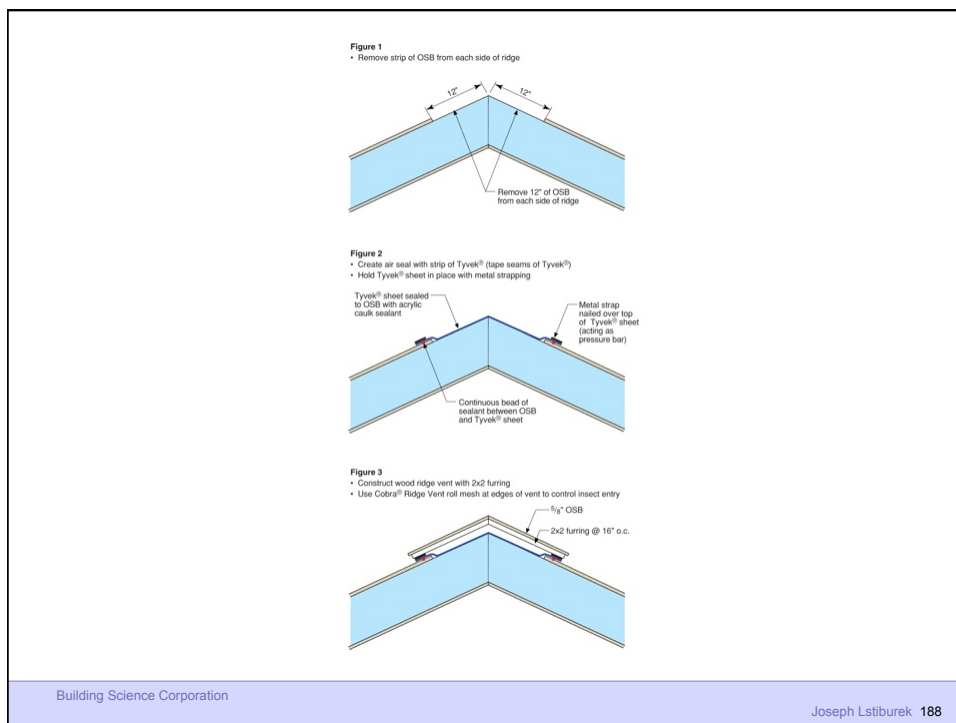
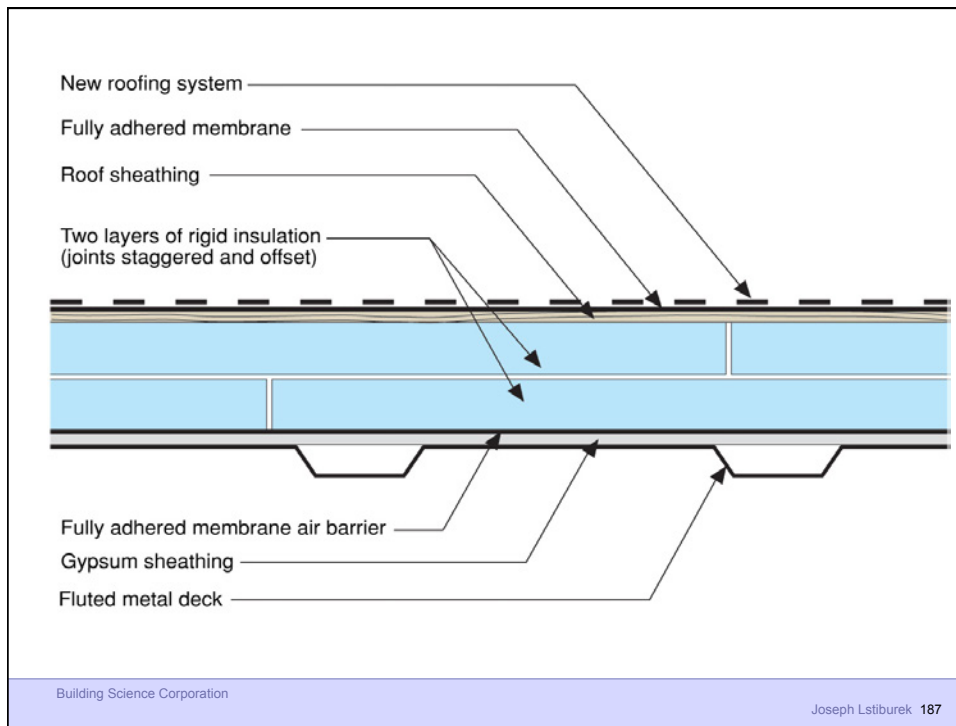



Building Science Corporation

Joseph Lstiburek 189



Building Science Corporation

Joseph Lstiburek 190





Building Science Corporation

Joseph Lstiburek 193



Building Science Corporation

Joseph Lstiburek 194



Building Science Corporation

Joseph Lstiburek 195



Building Science Corporation

Joseph Lstiburek 196





Building Science Corporation

Joseph Lstiburek 199



Building Science Corporation

Joseph Lstiburek 200

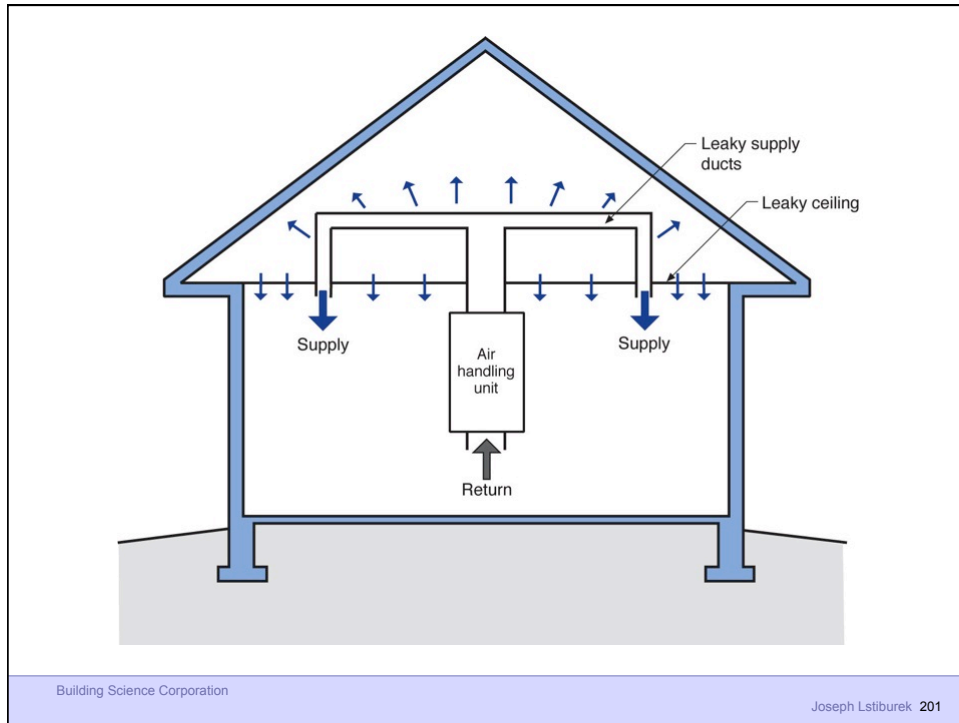

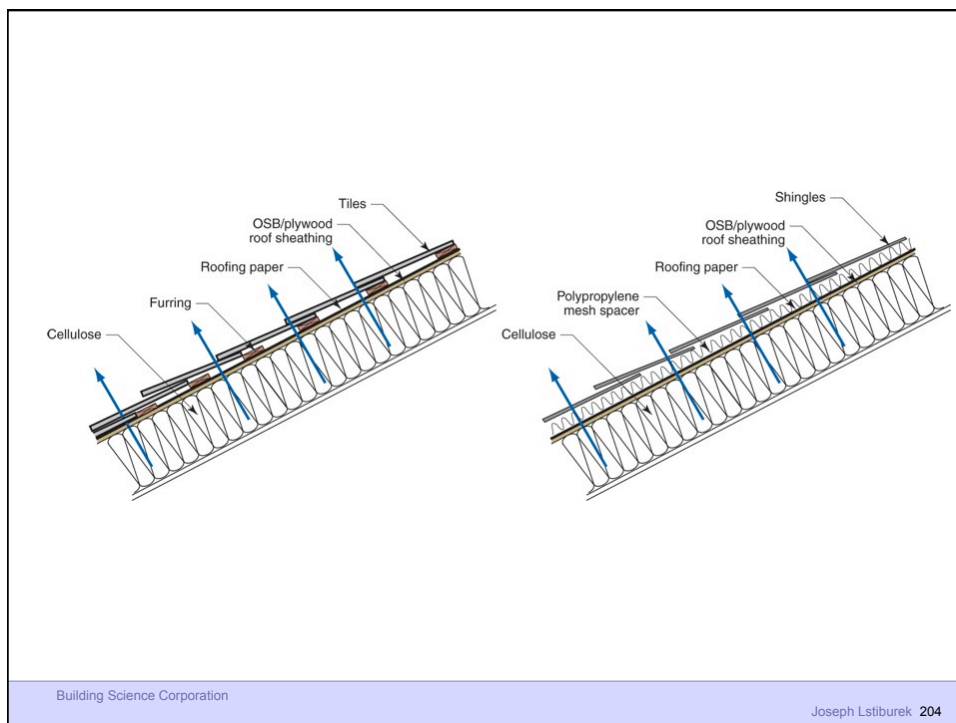
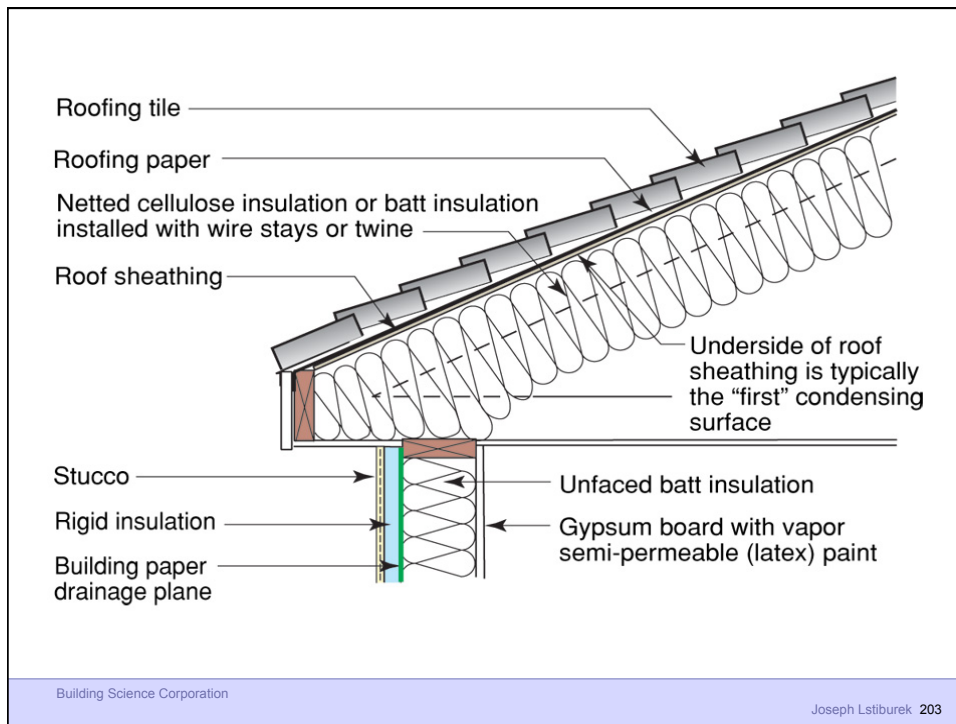

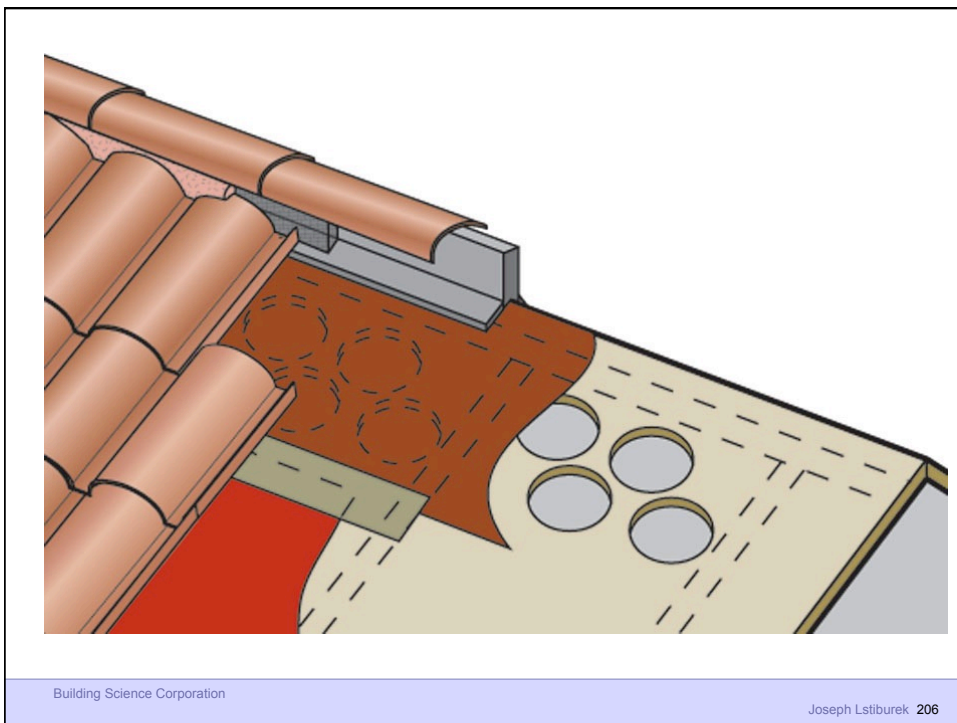
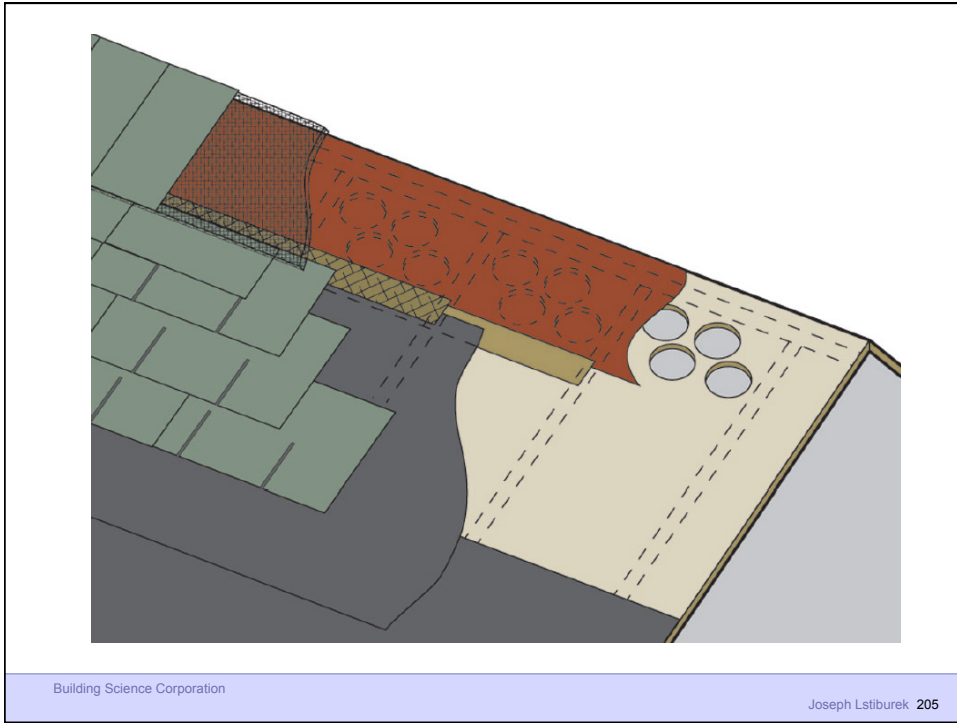

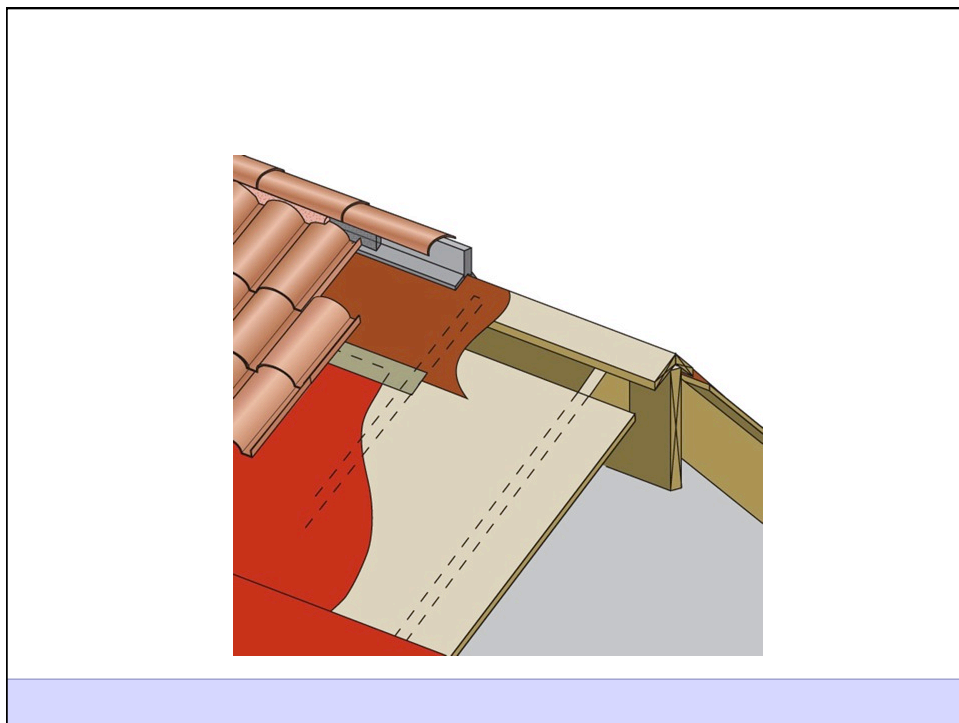
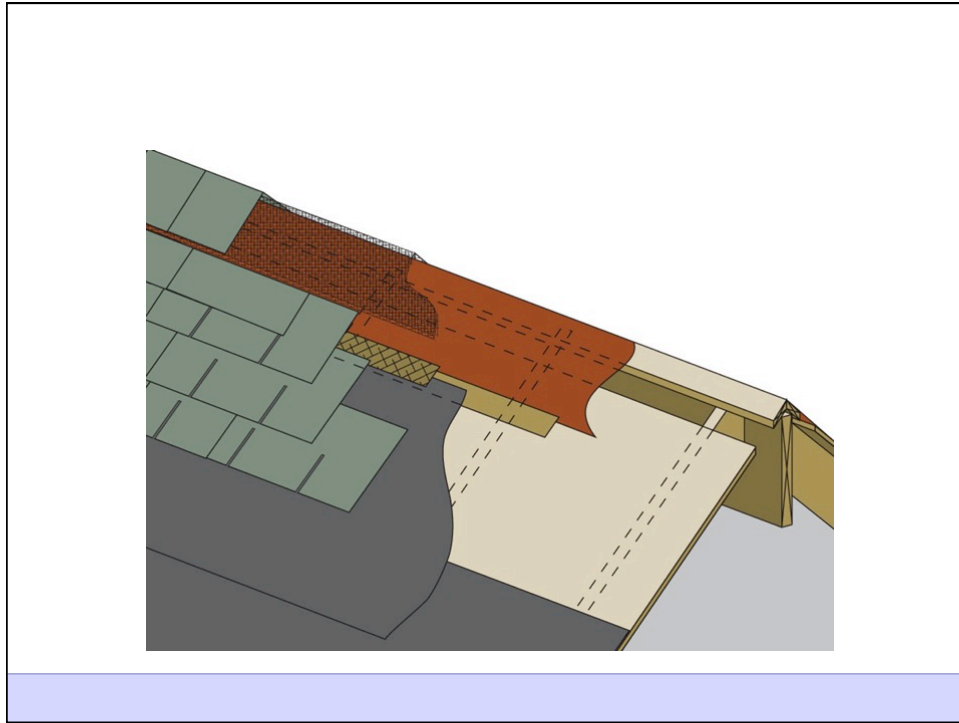

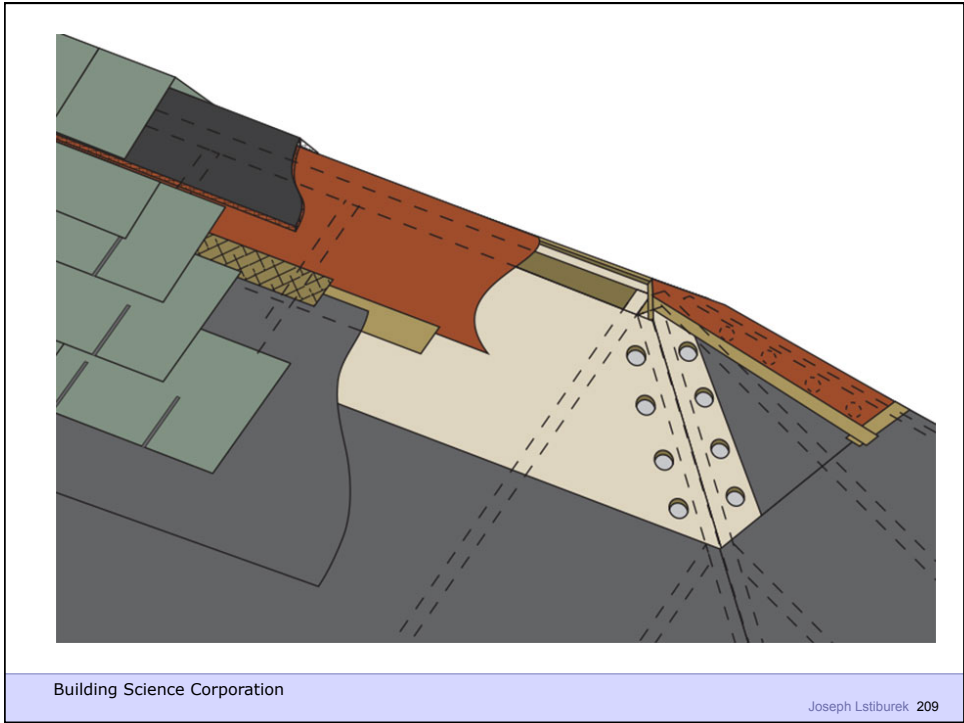



Building Science Corporation

Joseph Lstiburek 211



Building Science Corporation

Joseph Lstiburek 212



Building Science Corporation

Joseph Lstiburek 213



Building Science Corporation

Joseph Lstiburek 214