

Joseph Lstiburek, Ph.D., P.Eng, ASHRAE Fellow

Building Science

Adventures In Building Science

www.buildingscience.com

"It isn't what we don't know that gives us trouble, it's what we know that ain't so"

Will Rogers

"There are known knowns. These are things we know. There are known unknowns. There are things that we know we don't know. But there are also unknown unknowns. There are things we don't know we don't know.

Donald Rumsfeld

Building Science Corporation Joseph Lstiburek 2

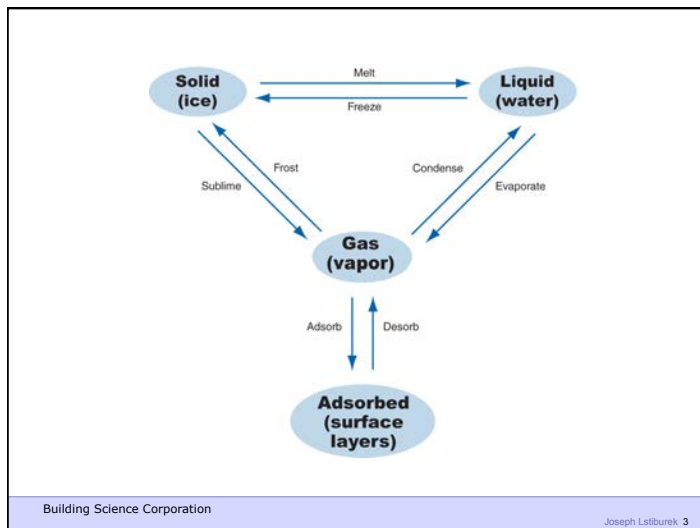

Moisture transport processes in building materials and components

Transport Process	Phase	Potential (Difference)
Gas diffusion	Vapor	Vapor pressure
Liquid diffusion	Liquid	Concentration
Surface diffusion	Adsorbate	Concentration
Thermal diffusion	Vapor and liquid	Temperature
Capillary flow	Liquid	Suction pressure
Convective flow	Vapor	Air pressure
Gravitational flow	Liquid	Height
Poiseuille flow	Liquid	Liquid pressure

From Kumaran, M. K.; Chapter 1, Moisture in Buildings, ASTM: 1994

Building Science Corporation Joseph Lstiburek 4

Water

- Vapor is a single molecule
- Liquid is molecular clumps, 75 or more

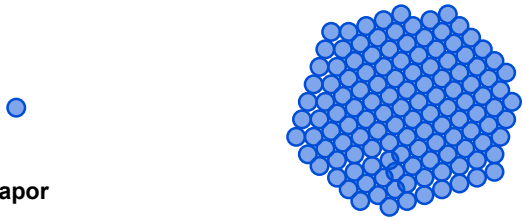

Vapor **Liquid**

Building Science Corporation

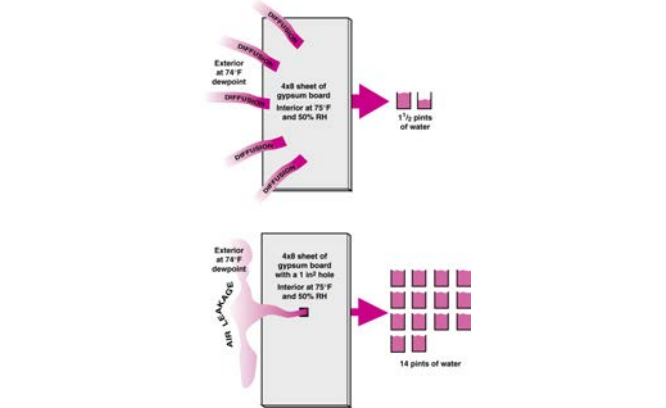

Building Science Corporation Joseph Lstiburek 6

The Water Molecule

- Asymmetrical = polar
- Small: one billion = one foot

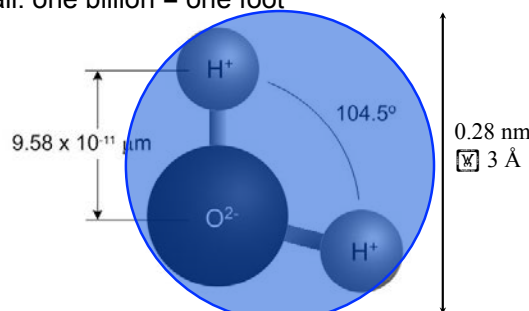

Building Science Corporation

The Polar Molecule

- Hydrogen end is “more” positive
- Oxygen end is “more” negative

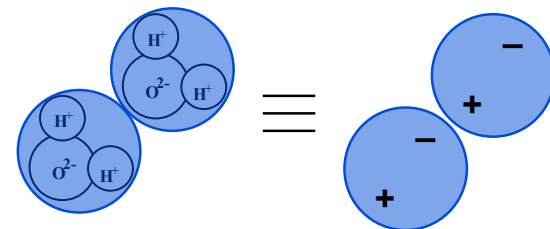

Building Science Corporation

Surface Tension: Wettable

Water attracted to surface more than self

$\theta < 90^\circ$

normal material: "wetable"

Water attracted to self more than surface

$\theta > 90^\circ$

hydrophobically treated: "non-wetable"

Building Science Corporation

Calculating capillary rise

$h = \frac{2 \sigma \cos \theta}{g \rho r}$

Building Science Corporation

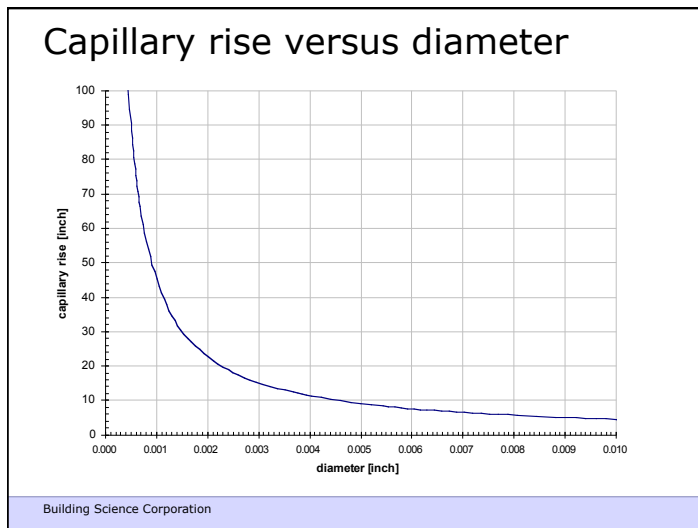

2nd Law of Thermodynamics

Building Science Corporation

Joseph Lstiburek 12

Heat Flow Is From Warm To Cold
 Moisture Flow Is From Warm To Cold
 Moisture Flow Is From More To Less
 Air Flow Is From A Higher Pressure to a Lower Pressure
 Gravity Acts Down

Building Science Corporation

Joseph Lstiburek 13

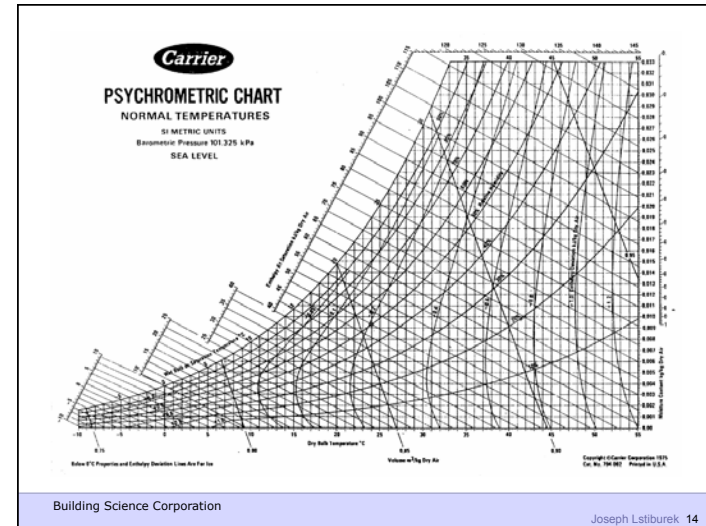

Building Science Corporation

Joseph Lstiburek 14

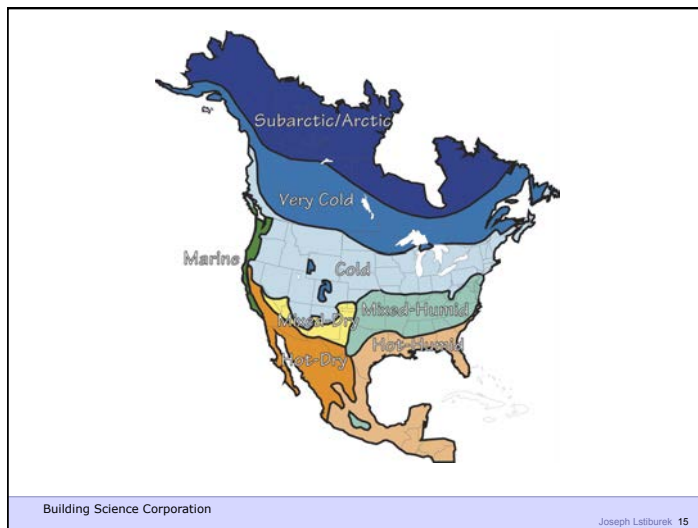

Building Science Corporation

Joseph Lstiburek 15

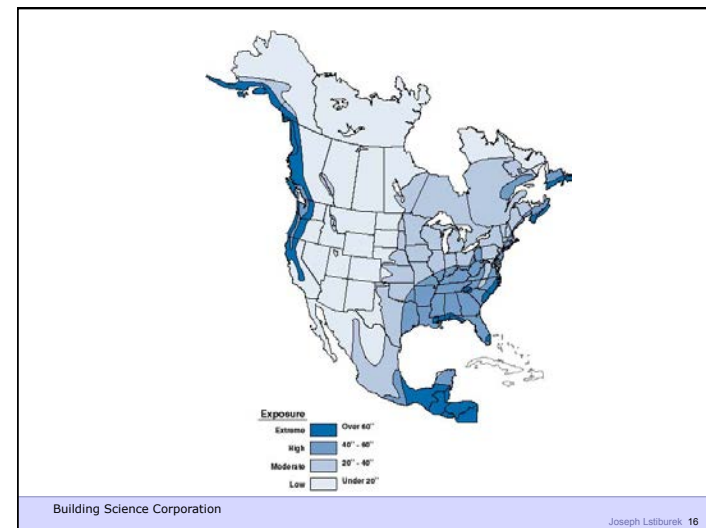

Building Science Corporation

Joseph Lstiburek 16

Don't Do Stupid Things

Building Science Corporation

Joseph Lstiburek 17



Building Science Corporation

Joseph Lstiburek 18



Building Science Corporation

Joseph Lstiburek 19



Building Science Corporation

Joseph Lstiburek 20

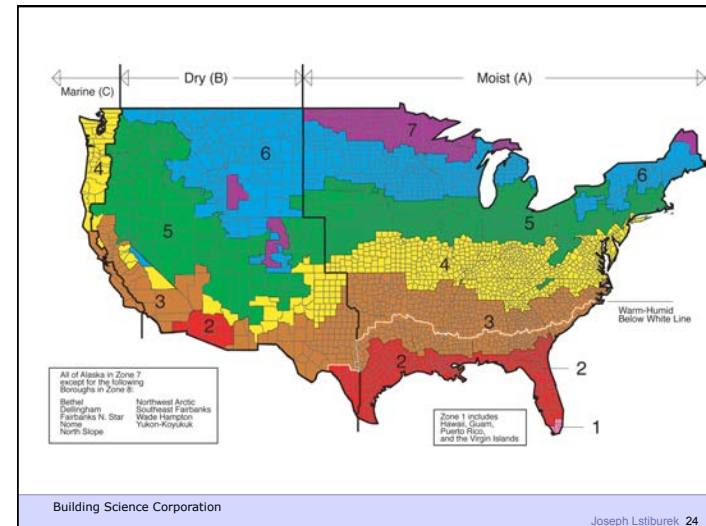
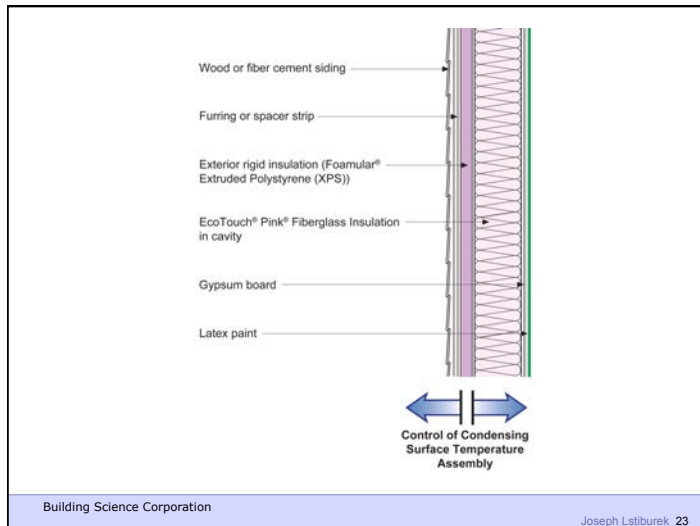
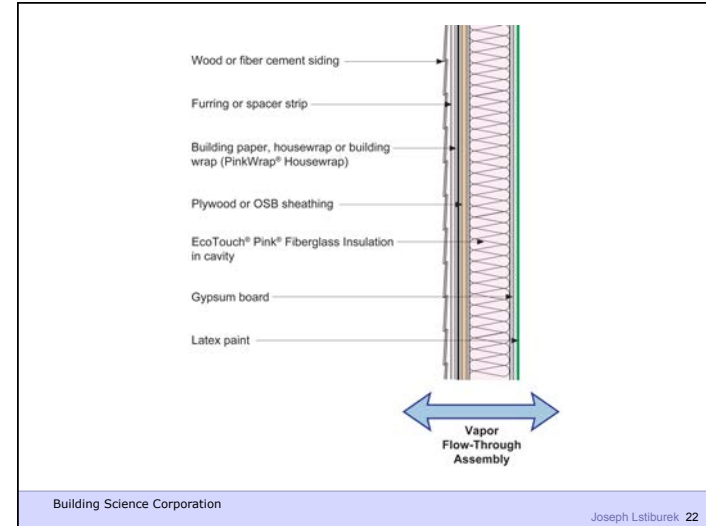

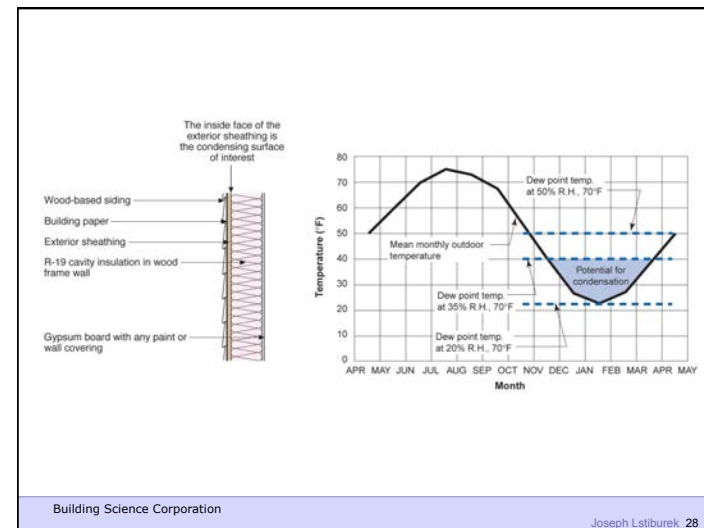
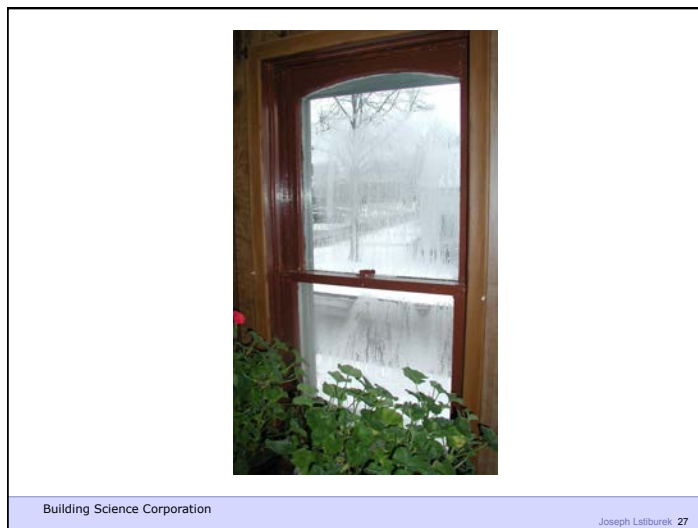
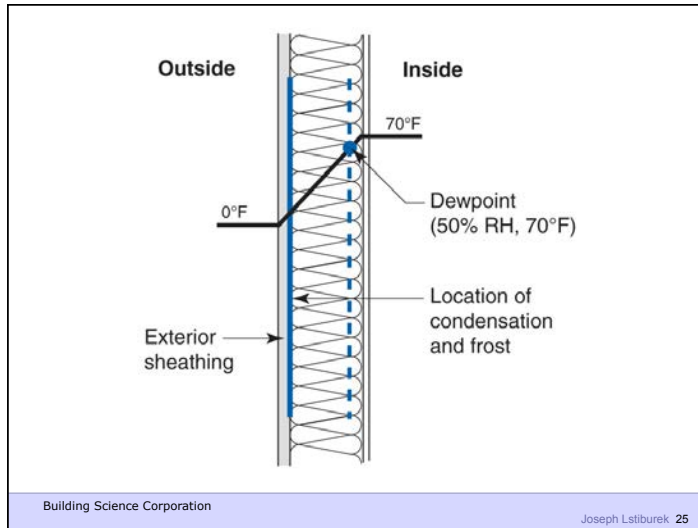

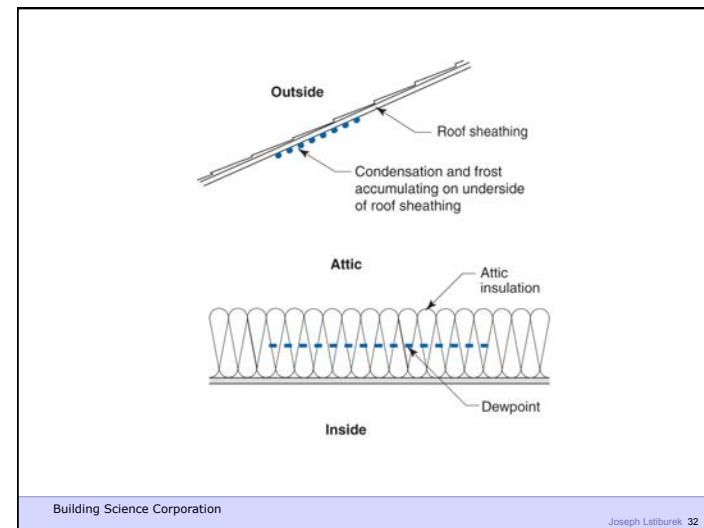
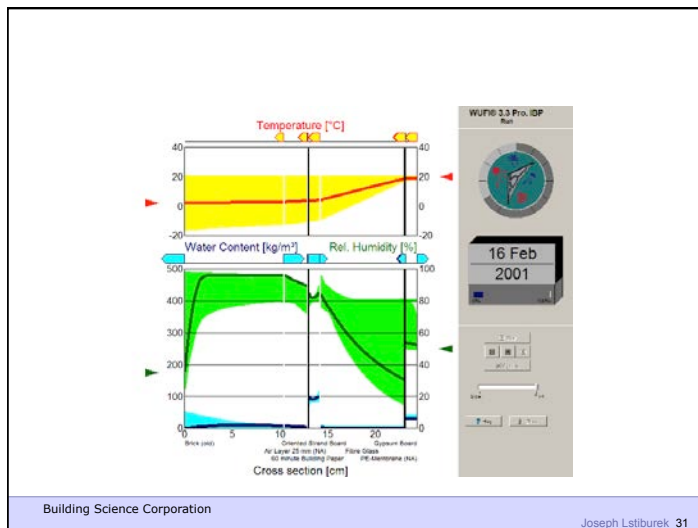
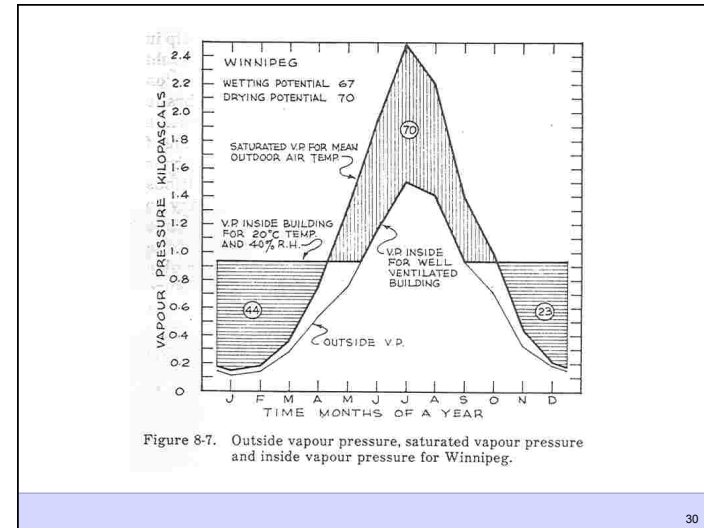
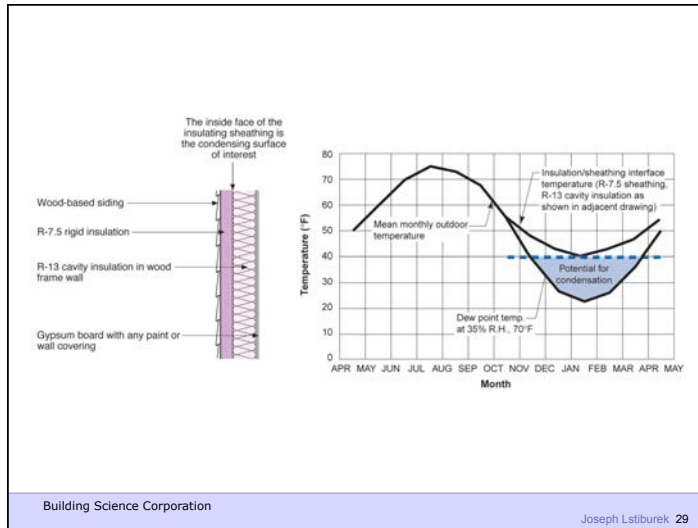

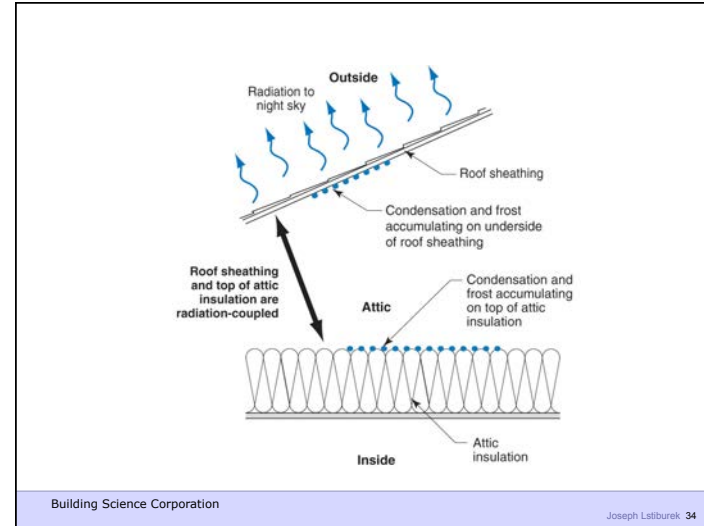

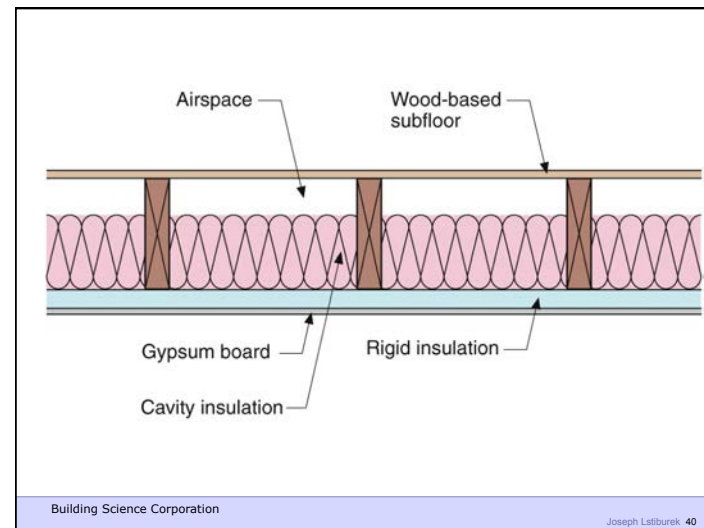
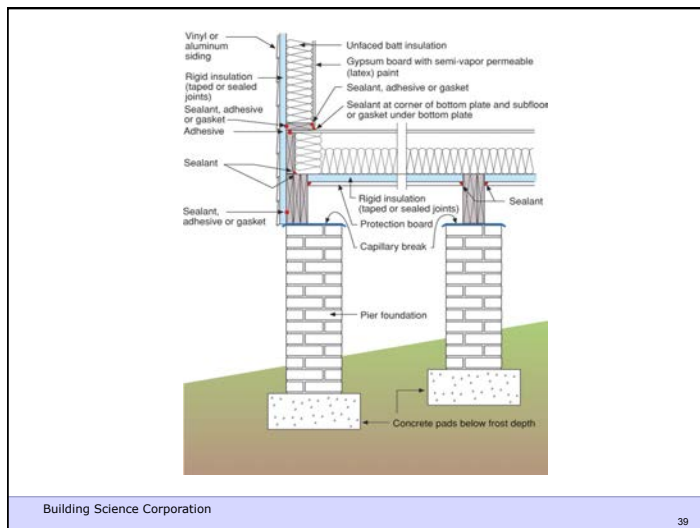
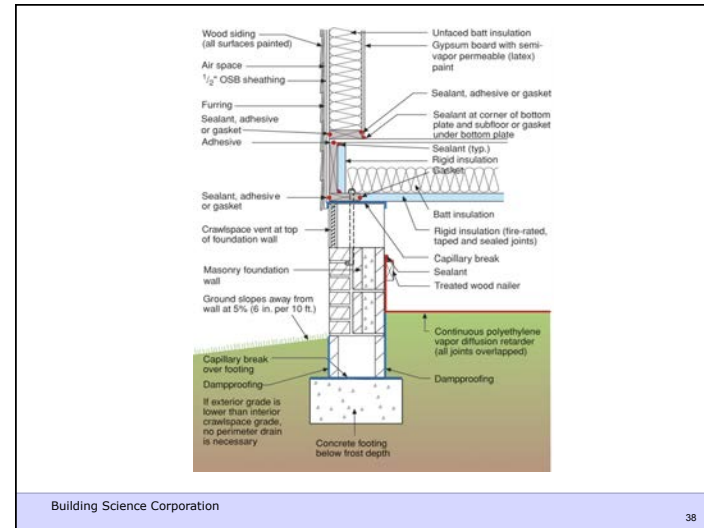
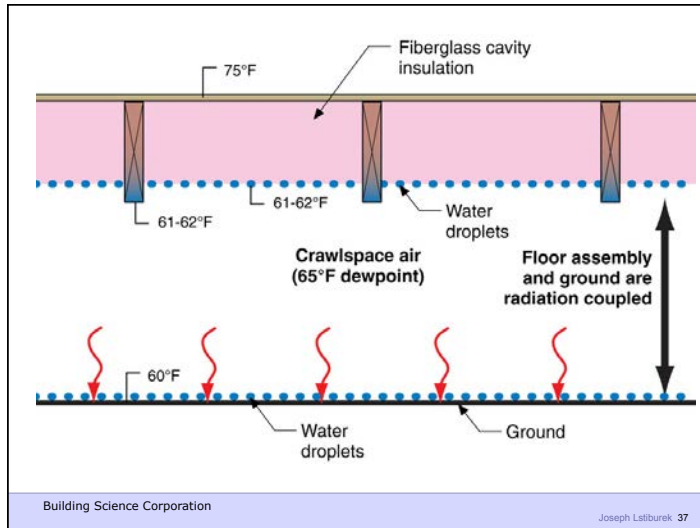

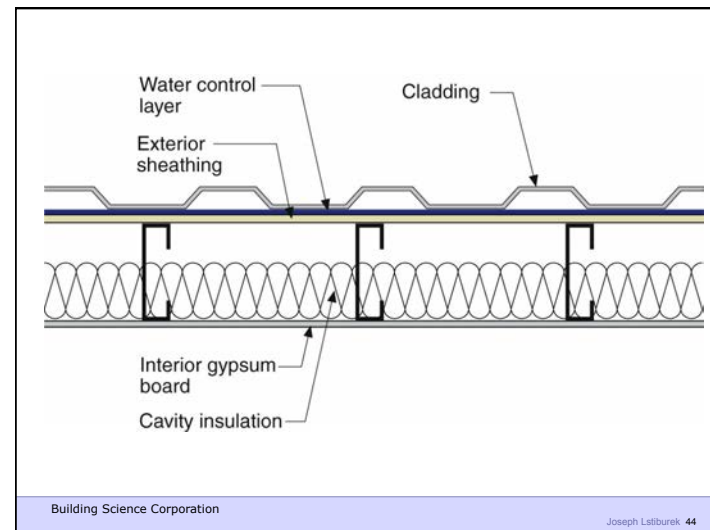
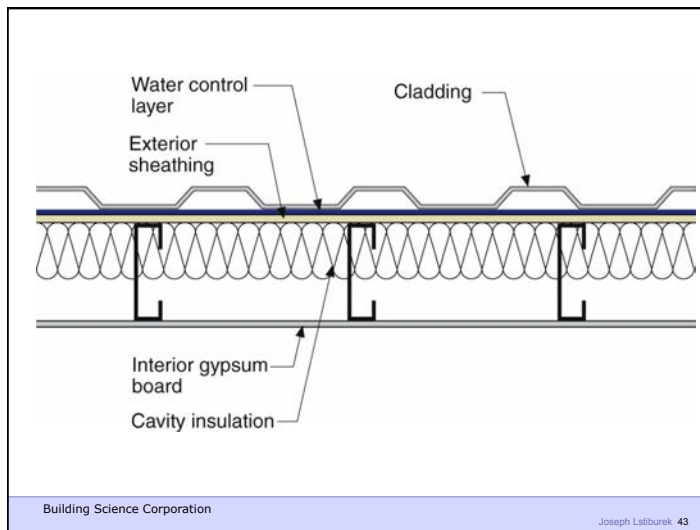
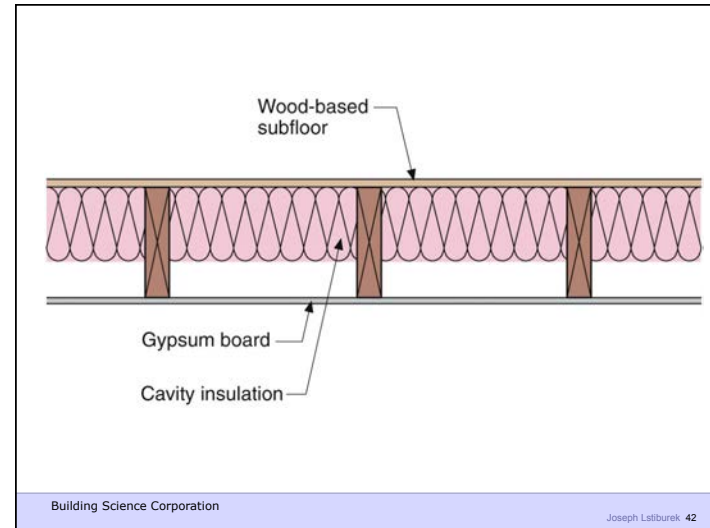
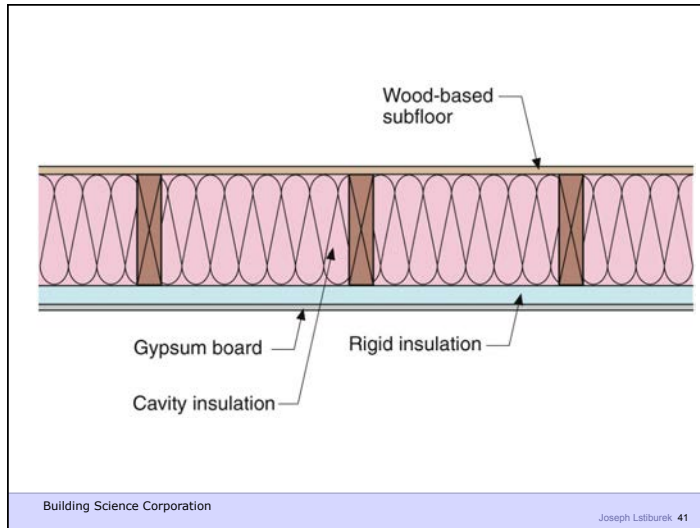

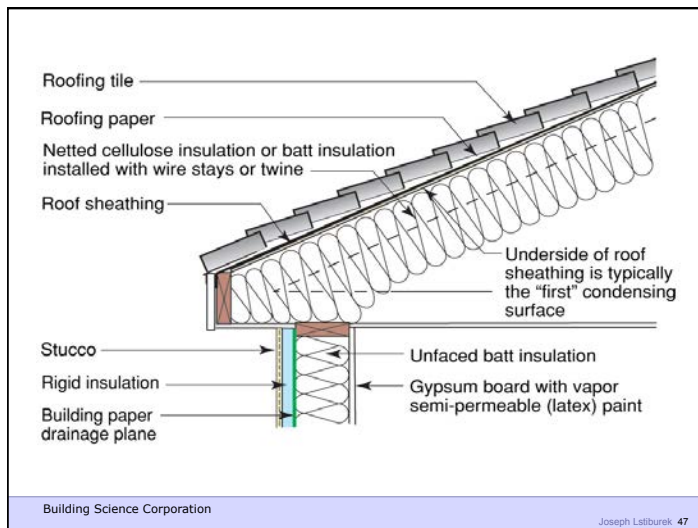
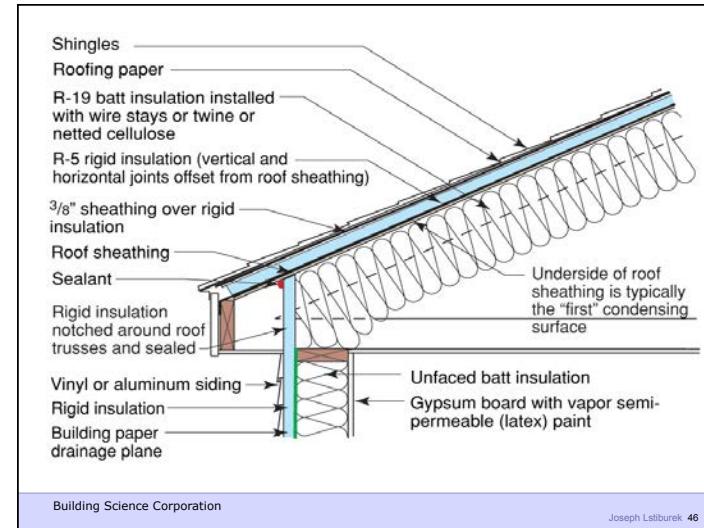
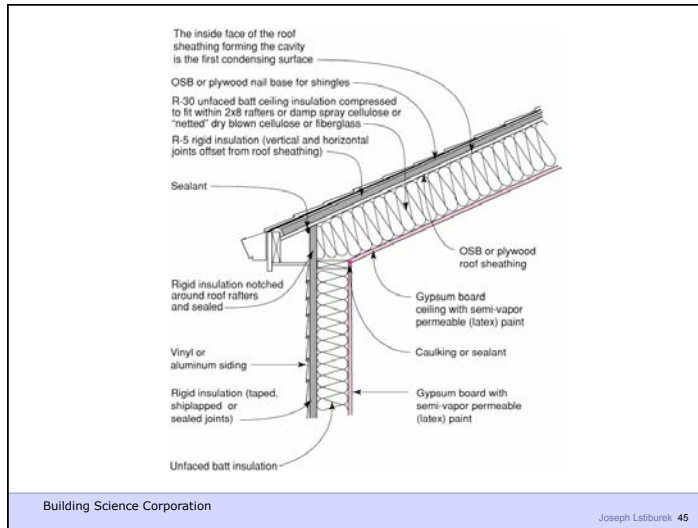

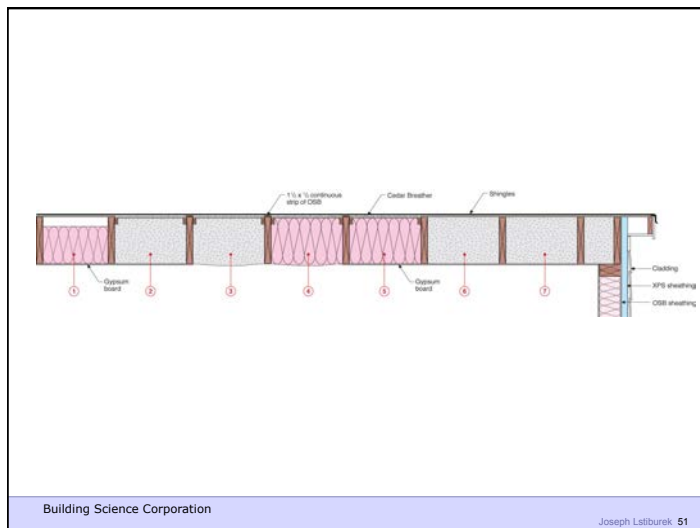
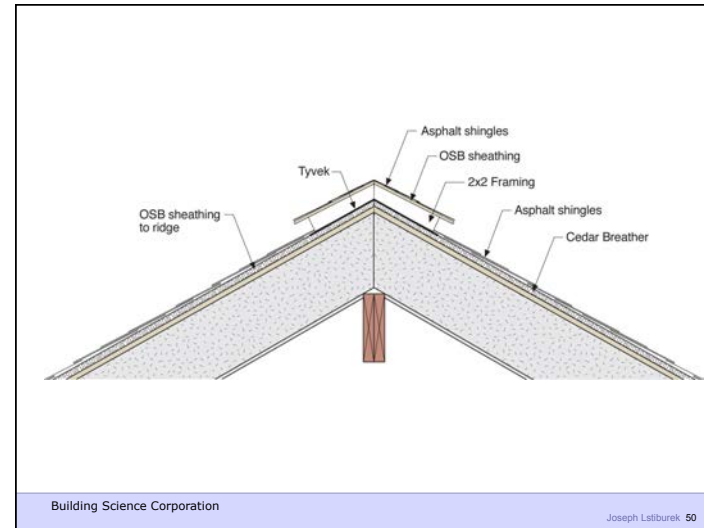
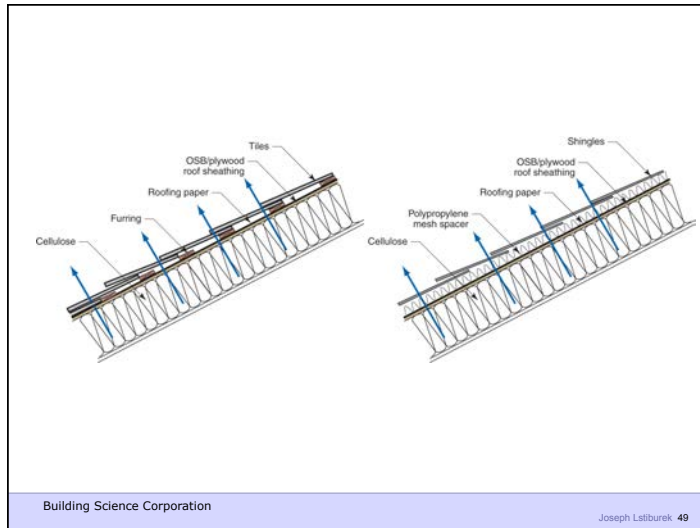

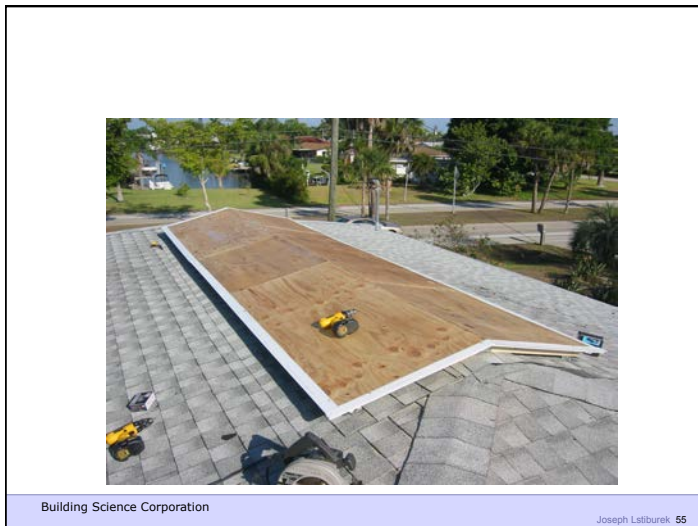
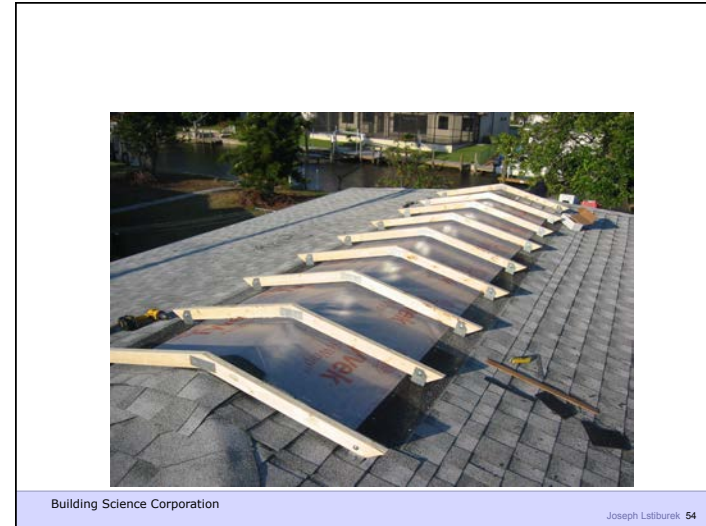

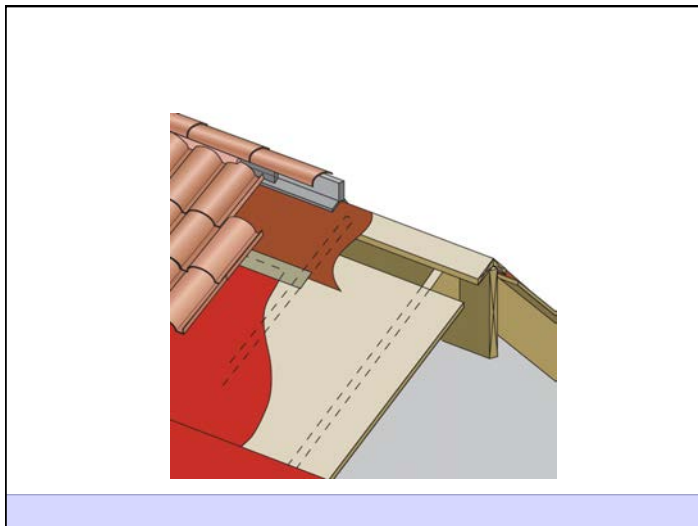
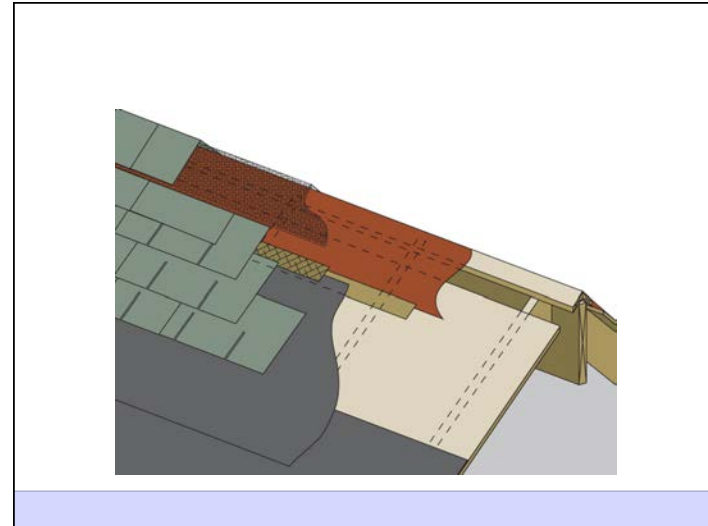

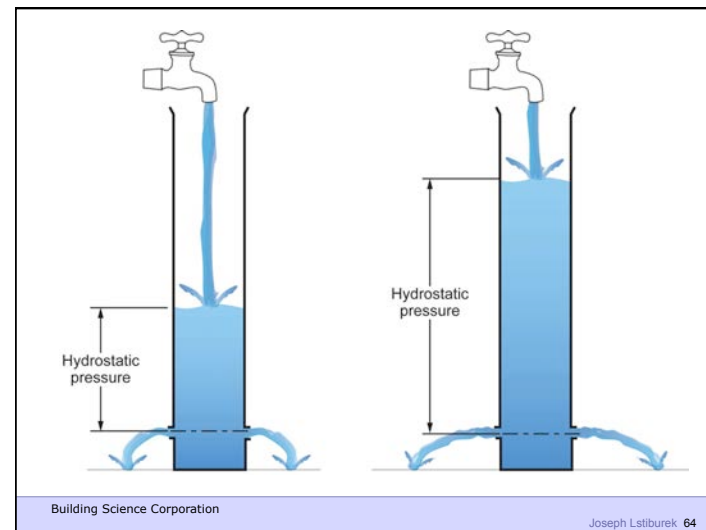
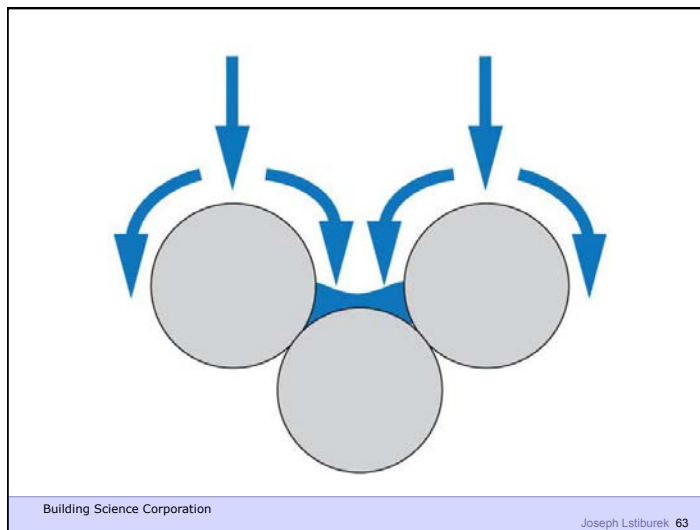
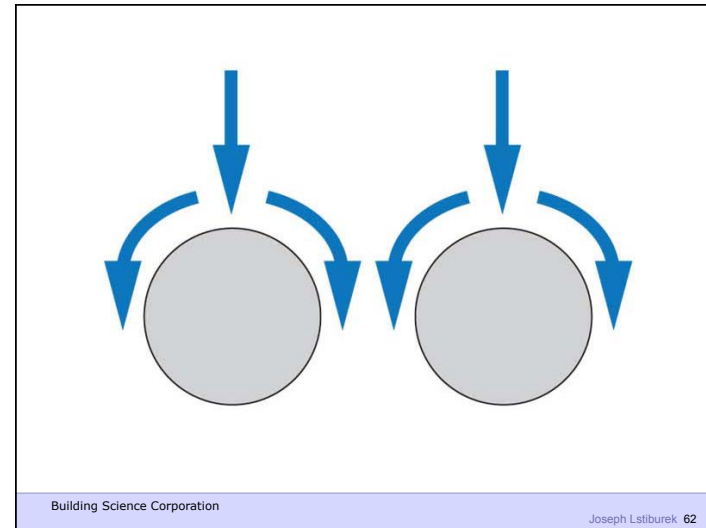
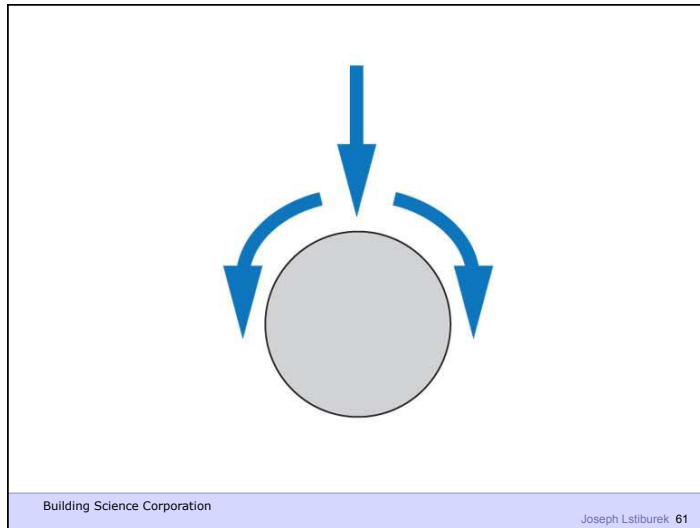

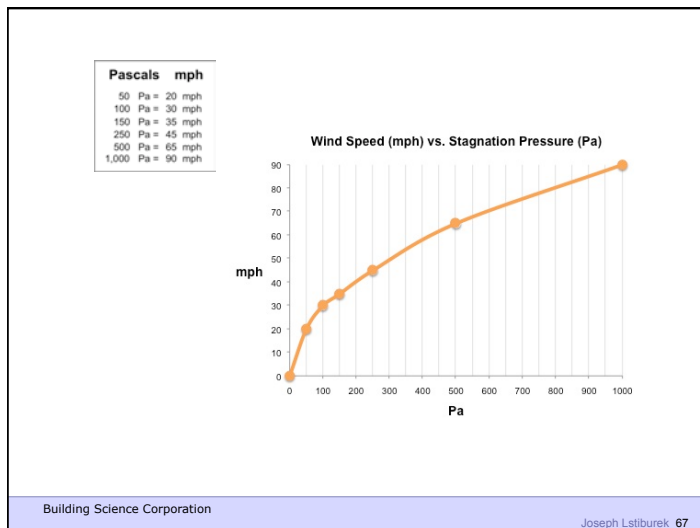
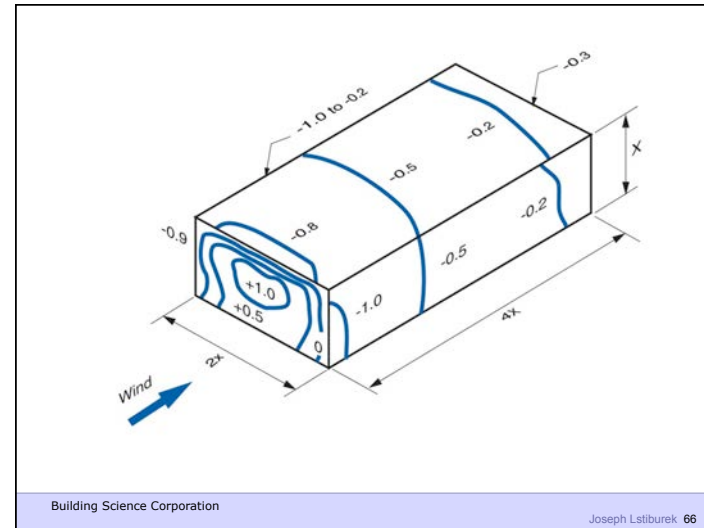
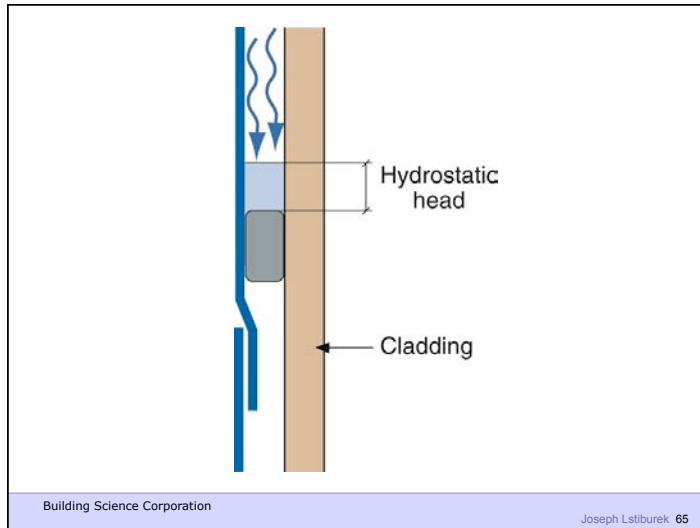

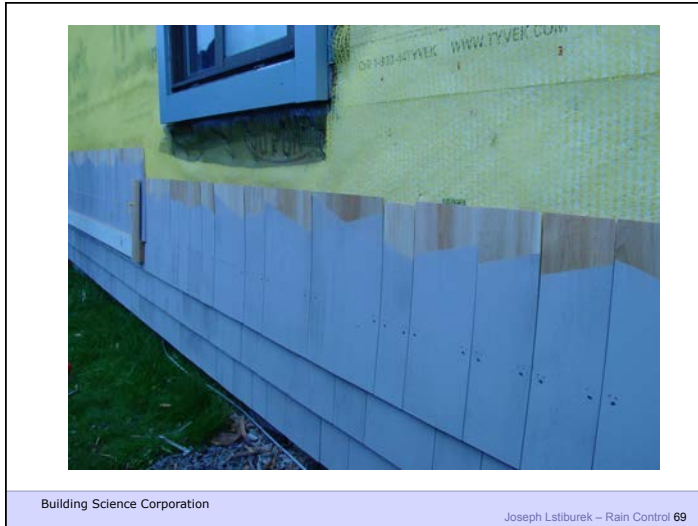

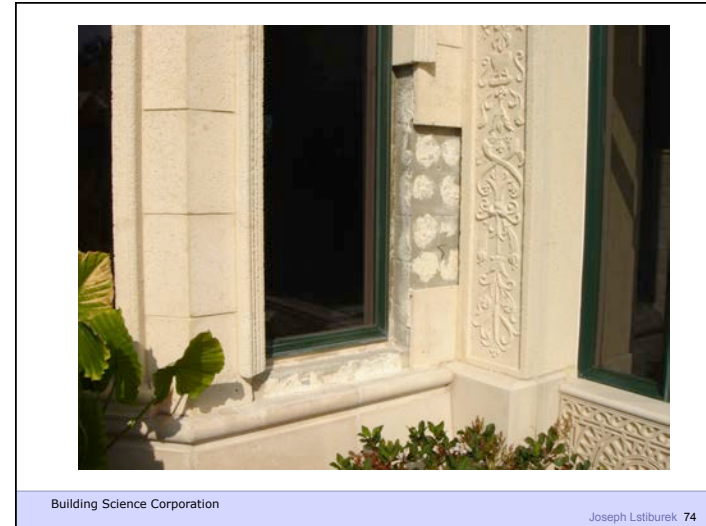
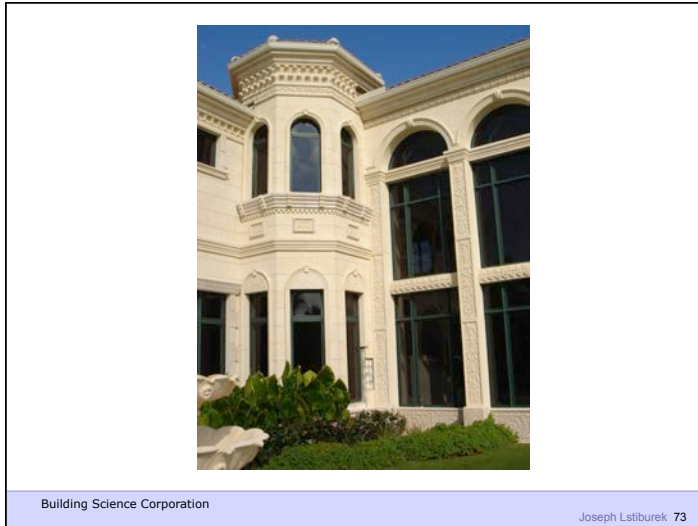

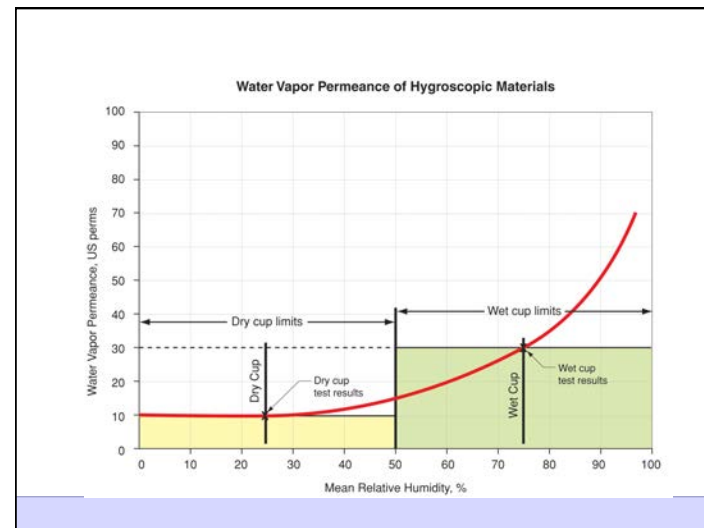
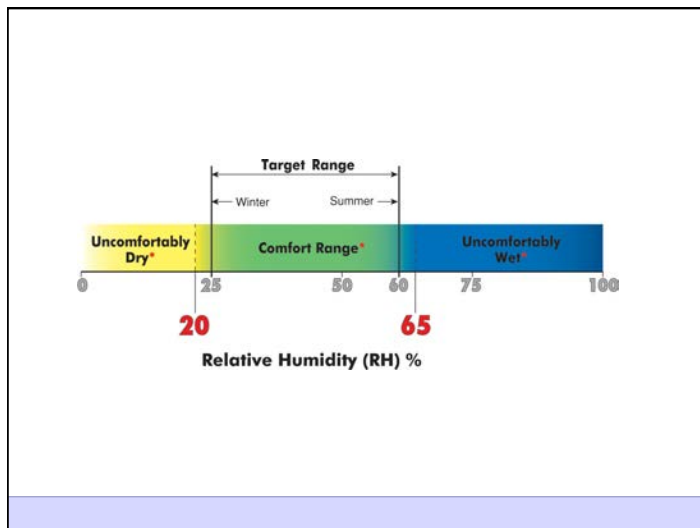
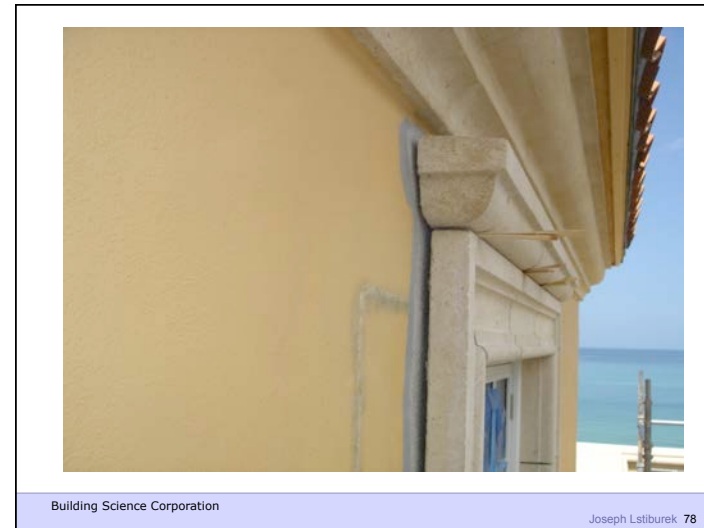
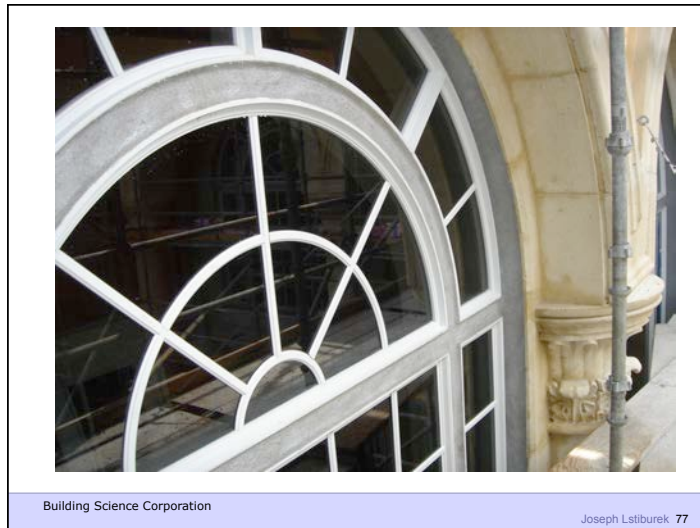

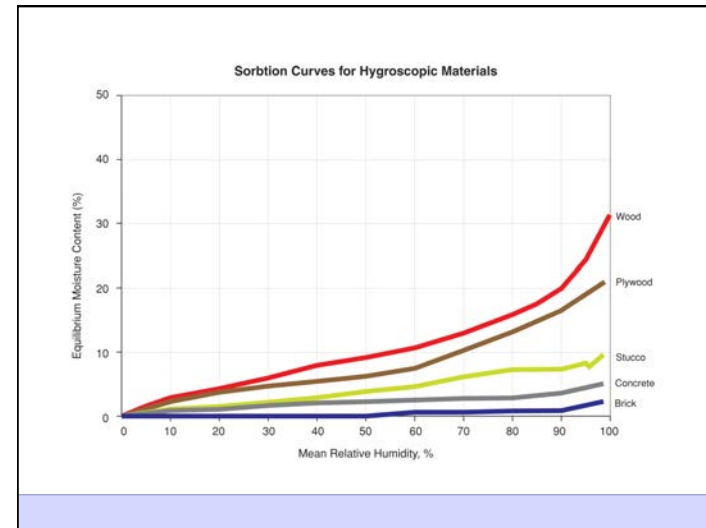
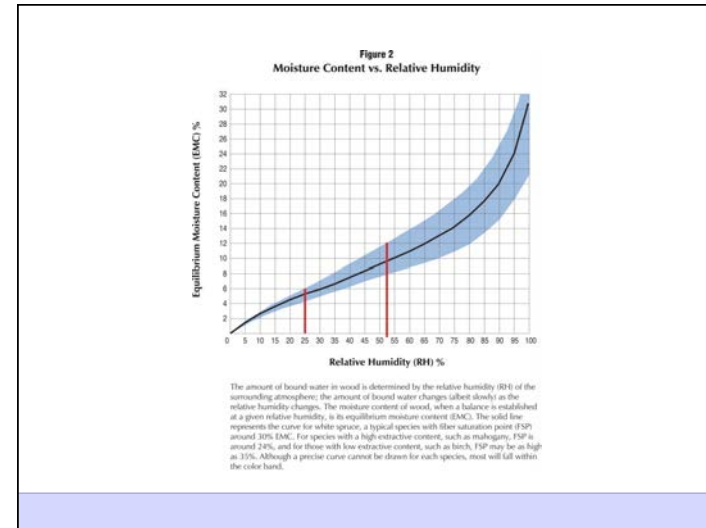
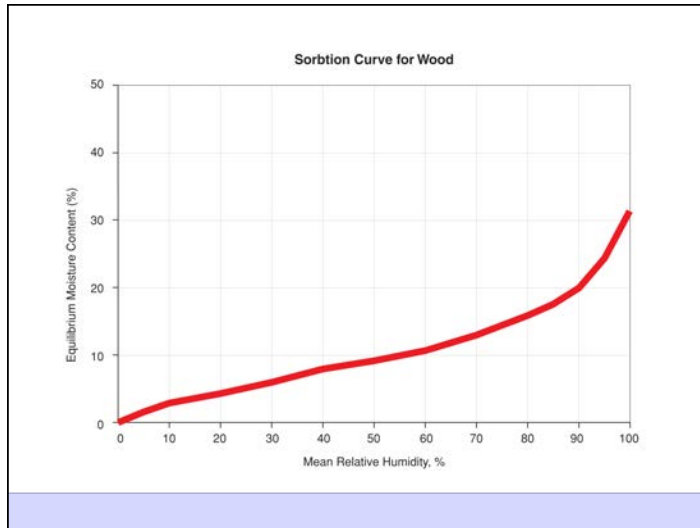

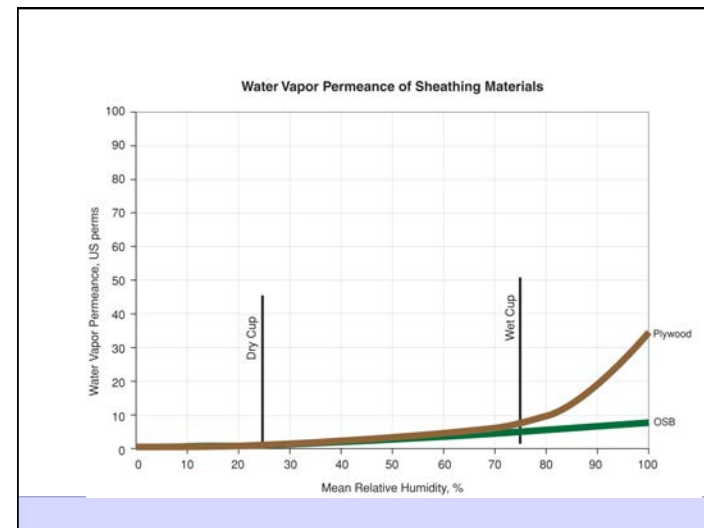
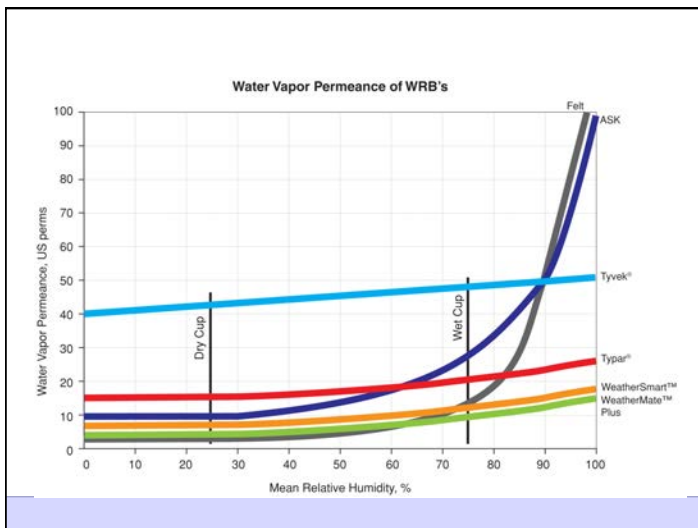
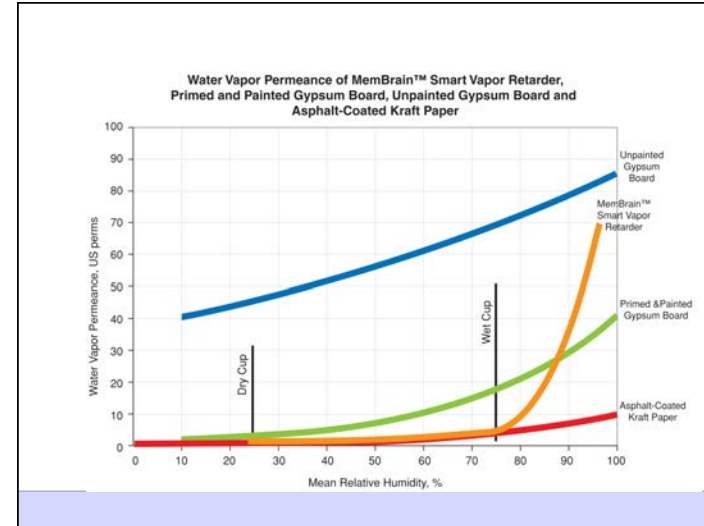
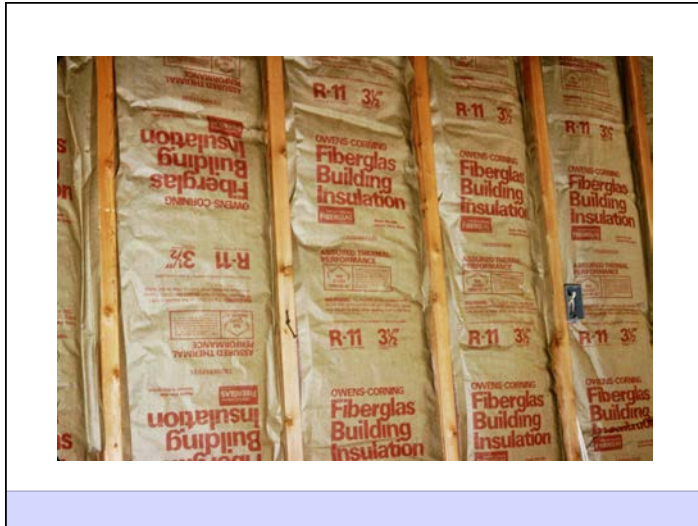

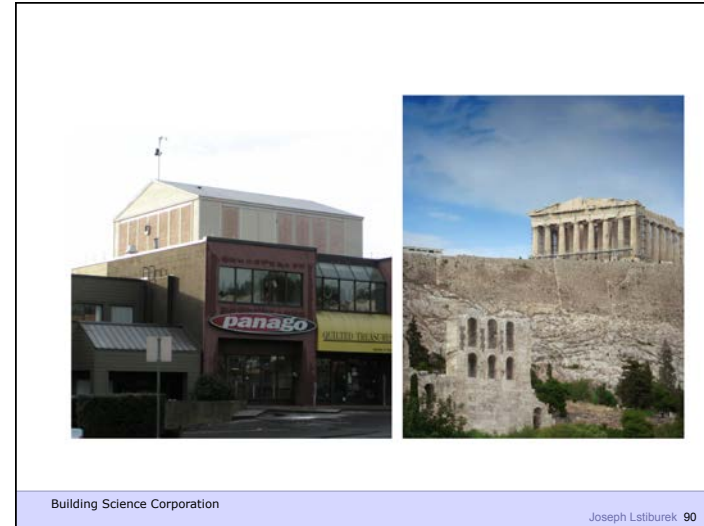
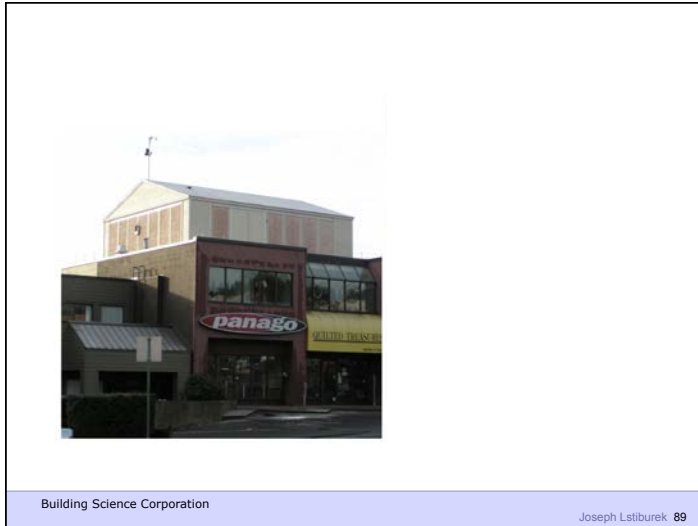

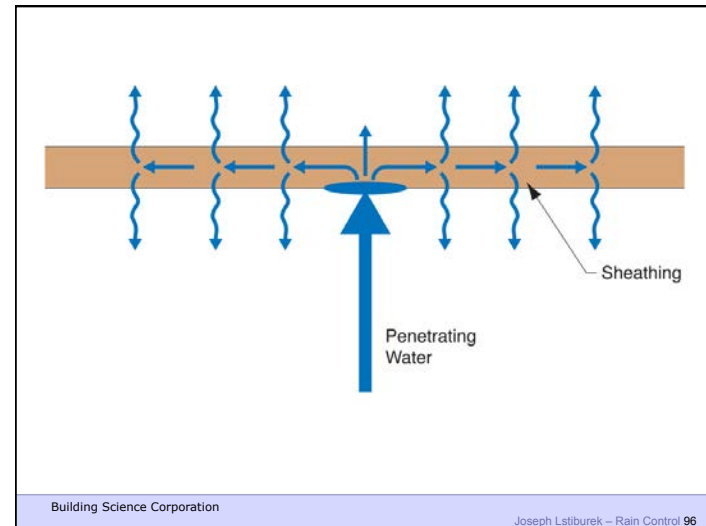
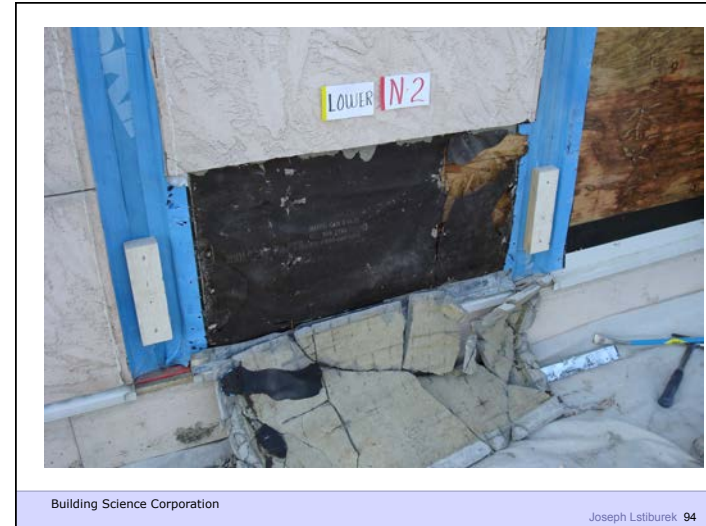

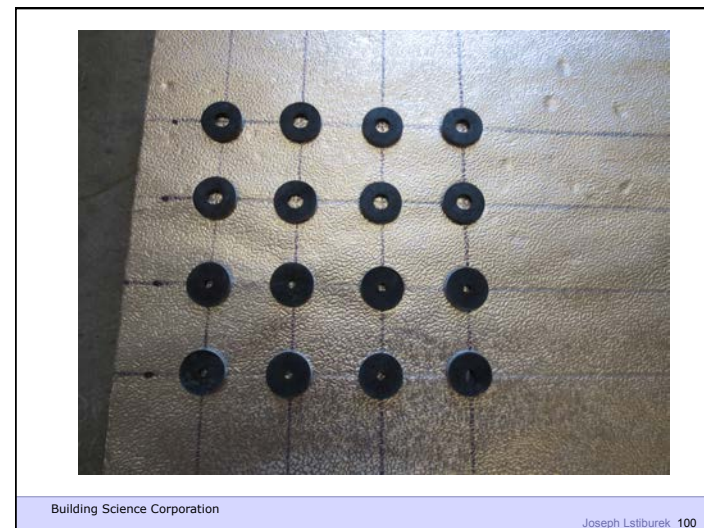
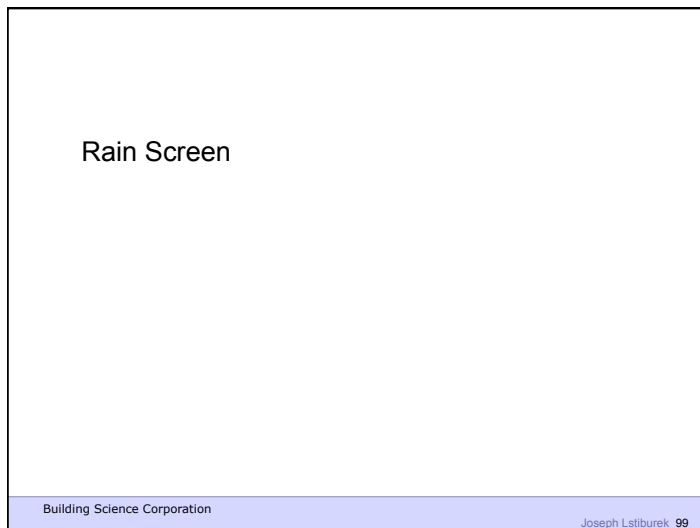
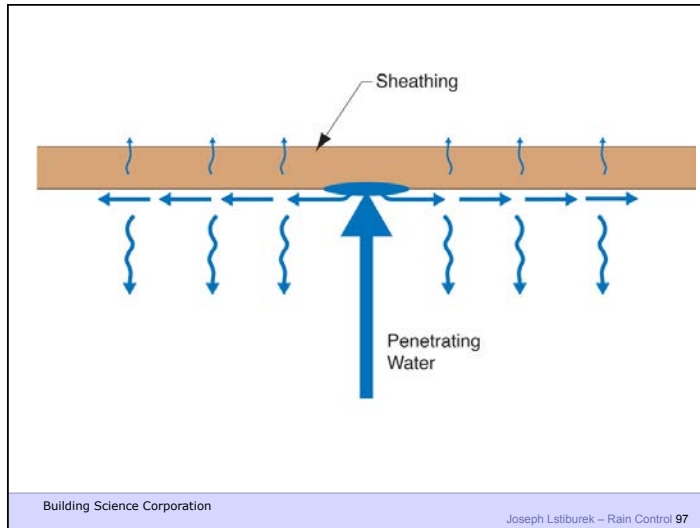

Beer Screen?

Building Science Corporation

Joseph Lstiburek 101

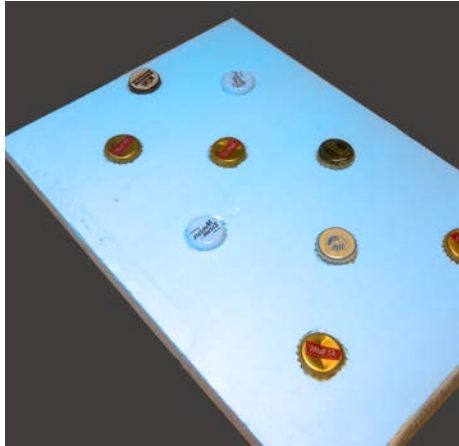

Building Science Corporation

Joseph Lstiburek 102

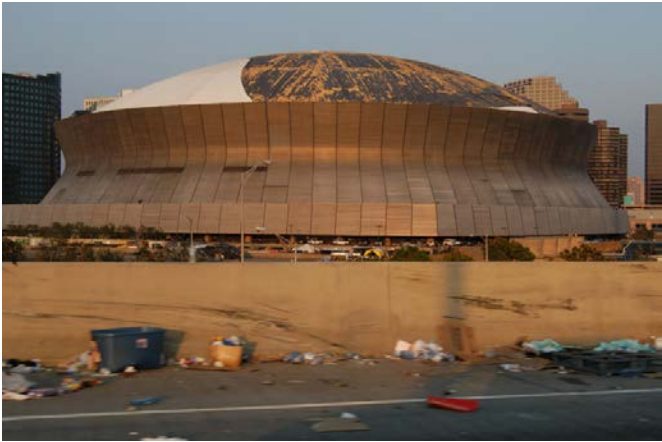

Building Science Corporation

Joseph Lstiburek 103

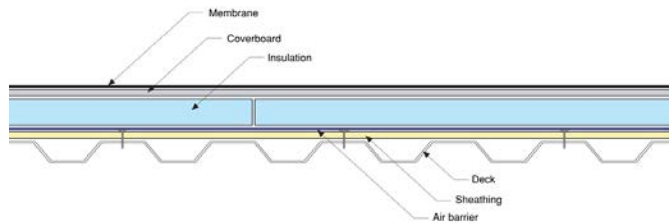

Building Science Corporation

Joseph Lstiburek 104

